

Report to the Advisory Committee of Experts for Nuclear Pressure Equipment

ASN Report reference CODEP-DEP-2017-019368

IRSN Report /2017-00011

English version

Public version



Session of 26 and 27 June 2017



**Analysis of the consequences of the anomaly in the
Flamanville EPR reactor pressure vessel head domes
on their serviceability**

| Date | ASN Director of Nuclear Pressure Equipment | IRSN Director of Systems, New Reactors and Safety Procedures |
|--------------|---|--|
| 15 June 2017 | This document is an English translation of the original report in French which is to be referred to for a guaranteed content. | |

CONTENTS

| | |
|---|-----------|
| REFERENCES | 7 |
| ACRONYMS, ABBREVIATIONS AND DESIGNATIONS..... | 12 |
| 1. INTRODUCTION..... | 16 |
| 2. DEMONSTRATION APPROACH..... | 18 |
| 2.1. Detection of the deviation and technical origin..... | 18 |
| 2.2. Principles of the Areva NP demonstration approach | 20 |
| 2.2.1. Degradation modes selected..... | 20 |
| 2.2.2. Assessment of the fracture risk in the brittle and brittle-ductile transition domains | 21 |
| 2.2.2.1. Determination of minimum toughness and mechanical properties in the positive macrosegregation zone | 22 |
| 2.2.2.2. Determination of the adequate toughness to demonstrate the preclusion of the risk of fast fracture | 23 |
| 2.2.2.3. Comparison between the minimum toughness and the adequate toughness | 23 |
| 2.2.3. Fracture risk assessment in the ductile domain | 24 |
| 2.3. Position statements by ASN since 2015 | 24 |
| 2.3.1. ASN position statement following the GP ESPN meeting of 30 June 2015 | 24 |
| 2.3.2. ASN position statement following the GP ESPN meeting of 24 June 2016 | 25 |
| 3. INSPECTION BY NON-DESTRUCTIVE TESTING DURING MANUFACTURING: SEARCH FOR FLAWS POTENTIALLY PRESENT IN THE REACTOR PRESSURE VESSEL CLOSURE HEAD AND BOTTOM HEAD..... | 26 |
| 3.1. Recapitulation of requests made by ASN following the GP ESPN sessions of 30 September 2015 and 24 June 2016..... | 26 |
| 3.2. Elements transmitted by Areva NP | 28 |
| 3.2.1. Elements transmitted by Areva NP in response to its undertakings | 28 |
| 3.2.2. Elements transmitted by Areva NP in response to the requests made by ASN..... | 28 |
| 3.2.2.1. Inspections to search for under-cladding flaws on the inner surface of the Flamanville EPR reactor pressure vessel lower and upper domes | 28 |
| 3.2.2.2. Performance of non-destructive tests on the reactor pressure vessel bottom head, other than dye-penetrant | 30 |
| 3.3. Position of the rapporteur | 33 |
| 3.3.1. Inspections performed during manufacturing..... | 35 |
| 3.3.2. Additional inspections of the outer surface of the domes | 35 |
| 3.3.3. Additional inspections to search for under-cladding flaws on the domes | 36 |
| 4. CHARACTERISATION OF THE MATERIAL..... | 37 |
| 4.1. Test programme | 37 |
| 4.1.1. Programme performed by Areva NP..... | 37 |
| 4.1.1.1. Content of the test programme | 37 |

| | | |
|-------------|--|-----------|
| 4.1.1.2. | Preparation and characterisation of the material | 39 |
| 4.1.1.3. | Choice of test and assessment laboratories | 43 |
| 4.1.1.4. | Carbon content measurement methods | 43 |
| 4.1.1.5. | Thermal ageing | 44 |
| 4.1.2. | Position of the rapporteur | 45 |
| 4.1.2.1. | Content of the test programme | 45 |
| 4.1.2.2. | Choice of test laboratories | 46 |
| 4.1.2.3. | Evaluation of uncertainties in the carbon content measurement | 46 |
| 4.1.2.4. | Thermal ageing | 47 |
| 4.1.3. | Monitoring of the test programme by a third-party organisation delegated by ASN | 48 |
| 4.1.3.1. | Monitoring objectives and methods | 48 |
| 4.1.3.2. | Quantitative monitoring report | 49 |
| 4.1.3.3. | Processing of deviations | 50 |
| 4.1.3.4. | Opinion of Bureau Veritas Exploitation | 50 |
| 4.1.4. | Position of rapporteur regarding implementation of the test programme | 50 |
| 4.2. | Representativeness of the scale-one replica domes with respect to those of the Flamanville EPR reactor pressure vessel..... | 51 |
| 4.2.1. | Principles of the Areva NP approach to analysis of the representativeness of the scale-one replica domes | 51 |
| 4.2.2. | Parameters influencing the carbon content | 52 |
| 4.2.2.1. | Documentary elements and numerical simulation evaluation | 52 |
| 4.2.2.2. | Experimental data | 56 |
| 4.2.3. | Parameters influencing the quenching effect | 58 |
| 4.2.3.1. | Documentary and analytical elements | 58 |
| 4.2.3.2. | Experimental data | 60 |
| 4.2.4. | Additional studies carried out by Areva NP | 63 |
| 4.2.4.1. | Uncertainty analyses and statistics | 63 |
| 4.2.4.1. | Comparison of carbon contents in the depth of the scale-one replica domes | 64 |
| 4.2.4.2. | Comparison with MOPPEC R&D bloom | 66 |
| 4.2.5. | Position of the rapporteur on the demonstration of representativeness | 67 |
| 4.3. | Results and interpretation of the test programme | 70 |
| 4.3.1. | Parameters influencing the mechanical properties | 70 |
| 4.3.2. | Tensile properties | 71 |
| 4.3.2.1. | In acceptance zone | 72 |
| 4.3.2.2. | In segregation zone | 73 |
| 4.3.3. | Impact strength properties | 74 |
| 4.3.4. | Temperatures T_{NDT} and RT_{NDT} | 77 |
| 4.3.4.1. | In acceptance zone | 78 |
| 4.3.4.2. | In segregation zone | 78 |
| 4.3.5. | Fracture toughness in the brittle-ductile transition domain | 80 |
| 4.3.5.1. | In acceptance zone | 82 |
| 4.3.5.2. | In segregation zone | 82 |
| 4.3.6. | Fracture toughness in the ductile zone | 86 |
| 4.3.7. | Fracture mechanisms | 87 |
| 4.3.7.1. | In the brittle-ductile transition domain | 87 |
| 4.3.7.2. | In the ductile domain | 87 |
| 4.3.8. | Position of the rapporteur concerning the mechanical properties in the segregation zone | 88 |
| 4.3.8.1. | Sufficiency of the knowledge provided by the test programme | 88 |
| 4.3.8.2. | Impact of the carbon content on the mechanical properties of the material | 89 |
| 4.3.8.3. | Improvement in quenchability linked to the carbon content and quenching effect | 90 |
| 4.3.8.4. | Fracture mechanism in segregation zone | 91 |
| 4.3.8.5. | Conservatism of the ZG6110 toughness curve in the RCC-M code when defining minimum toughness in the segregation zone | 92 |
| 4.3.8.6. | Fracture toughness in the ductile domain in the segregation zone | 93 |
| 4.3.9. | Transposition of the results obtained on the scale-one replica domes to the domes of the Flamanville 3 EPR reactor pressure vessel | 93 |

| | | |
|-------------|---|------------|
| 4.3.9.1. | NP Areva file..... | 93 |
| 4.3.9.2. | Position of the rapporteur..... | 95 |
| 5. | THERMOMECHANICAL LOADINGS..... | 97 |
| 5.1. | Pertinent thermohydraulic parameters | 98 |
| 5.2. | Hot shock situations | 98 |
| 5.2.1. | Identification of selected hot shock situations | 98 |
| 5.2.2. | Characterisation of hot shock situations | 99 |
| 5.3. | Cold shock situations | 100 |
| 5.3.1. | Identification of cold shock situations | 100 |
| 5.3.2. | Characterisation of cold shock situations | 100 |
| 5.4. | Position of the rapporteur | 102 |
| 5.4.1. | Common questions for hot shock and cold shock situations | 102 |
| 5.4.2. | Hot shock situations..... | 102 |
| 5.4.2.1. | Identification of hot shock situations | 102 |
| 5.4.2.2. | Pertinence of the characterisation of hot shock situations | 103 |
| 5.4.3. | Cold shock situations | 103 |
| 5.4.3.1. | Identification of cold shock situations..... | 103 |
| 5.4.3.2. | Pertinence of the characterisation of cold shock situations | 103 |
| 5.5. | Conclusions of the rapporteur | 107 |
| 6. | ANALYSIS OF THE FAST FRACTURE RISK..... | 109 |
| 6.1. | Fast fracture risk assessment procedure..... | 109 |
| 6.2. | Postulated flaws..... | 110 |
| 6.3. | Methods of calculating the stress intensity factor associated with each type of flaw | 111 |
| 6.4. | Restrictive loadings considered..... | 112 |
| 6.5. | Fracture margins in the brittle-ductile transition zone..... | 113 |
| 6.5.1. | 10-mm high flaw | 113 |
| 6.5.2. | Margins for a conventional 20-mm high flaw..... | 115 |
| 6.6. | Position of the rapporteur concerning the fast fracture risk analysis | 115 |
| 6.6.1. | Approach | 115 |
| 6.6.2. | Toughness..... | 115 |
| 6.6.3. | Method of calculating the stress intensity factor | 116 |
| 6.6.4. | Flaw size | 116 |
| 6.6.5. | Loadings adopted..... | 117 |
| 6.6.6. | Fracture margins | 117 |
| 7. | IMPACT OF THE IRREGULARITIES DETECTED WITHIN THE AREVA NP CREUSOT FORGE PLANT IN THE HANDLING OF THE ANOMALY IN THE FLAMANVILLE EPR RPV DOMES..... | 118 |
| 7.1. | Detection of deviations | 118 |
| 7.2. | Deviations detected..... | 119 |

| | | |
|-----------|---|------------|
| 7.3. | Position of the rapporteur | 119 |
| 8. | IN-SERVICE INSPECTION | 122 |
| 8.1. | Areva NP file..... | 122 |
| 8.1.1. | Summary of ASN requests | 122 |
| 8.1.2. | Position of Areva NP | 122 |
| 8.1.2.1. | Inspectability of the Flamanville EPR reactor pressure vessel lower dome | 123 |
| 8.1.2.2. | Inspectability of the Flamanville EPR reactor pressure vessel upper dome | 124 |
| 8.2. | Position of the rapporteur | 124 |
| 8.2.1. | Principle of defence in depth and break preclusion | 124 |
| 8.2.1.1. | Principle of defence in depth | 124 |
| 8.2.1.2. | Break preclusion | 125 |
| 8.2.2. | Consequences on the serviceability of the Flamanville EPR reactor pressure vessel head domes | 126 |
| 8.2.2.1. | Analysis of the first level of defence in depth | 126 |
| 8.2.2.2. | Reinforcement of the second level of defence in depth | 127 |
| 9. | GENERAL CONCLUSION | 134 |
| | APPENDIX 1: TABLES AND FIGURES | 139 |
| | APPENDIX 2: DIAGRAMS AND COMPONENTS OF THE FLAMANVILLE EPR REACTOR PRESSURE VESSEL..... | 140 |
| | APPENDIX 3: DIAGRAM OF THE PRIMARY COOLING SYSTEM AND CONNECTED SYSTEMS, PARTICULARLY THE RIS-RA SYSTEM | 141 |
| | APPENDIX 4: ANALYSIS OF THE THERMOMECHANICAL LOADINGS - POINTS COMMON TO THE THERMOHYDRAULIC SITUATIONS OF HOT SHOCK AND COLD SHOCK | 142 |
| | APPENDIX 5: THERMOMECHANICAL LOADINGS - CHARACTERISATION OF HOT SHOCK TRANSIENTS | 146 |
| | APPENDIX 6: THERMOMECHANICAL LOADINGS - EXHAUSTIVENESS AND CHARACTERISATION OF THE CATEGORY-3 AND CATEGORY-4 COLD SHOCK THERMOHYDRAULIC TRANSIENTS | 157 |
| | APPENDIX 7: RPV DOME REPLACEMENT SCENARIOS | 162 |
| | APPENDIX 8: FORGING PROCESSES FOR THE LOWER AND UPPER DOMES OF THE FLAMANVILLE EPR REACTOR..... | 168 |
| | APPENDIX 9: SYNTHESIS OF THE MAPPINGS OF CARBON CONTENT AT THE SURFACE OF THE DOMES..... | 169 |
| | APPENDIX 10: SYNTHESIS OF CARBON CONTENT MAPPINGS IN THICKNESS OF DOMES | 174 |

| | |
|---|------------|
| APPENDIX 11: SYNTHESIS OF CARBON CONTENT MAPPINGS BY DEPTH ... | 175 |
| APPENDIX 12: LIST OF THERMOHYDRAULIC SITUATIONS CONSIDERED IN THE MECHANICAL ANALYSES | 176 |
| APPENDIX 13: CHANGE IN TOUGHNESS AND STRESS INTENSITY FACTOR AS A FUNCTION OF TEMPERATURE..... | 177 |
| APPENDIX 14: SAFETY FACTORS FOR THE RT_{NDT} OFFSETS OF 70°C ON OUTER SURFACE AND 35°C ON INNER SURFACE | 178 |
| APPENDIX 15: AREVA NP RESPONSES TO ASN REQUESTS..... | 180 |

References

- [1] European Directive 2014/68/UE of 15 May 2014 on the harmonisation of legislation in the Member States concerning the marketing of pressure equipment (rewrite)
- [2] Order of 10 November 1999 relative to the monitoring of operation of the main primary system and the main secondary systems of nuclear pressurized water reactors
- [3] Order of 12 December 2005 replaced by the order of 30 December 2015 concerning nuclear pressure equipment, known as the "ESPN order"
- [4] BNI order of 7 February 2012 amended, setting the general rules concerning basic nuclear installations
- [5] ASN/IRSN report reference CODEP-DEP-2015-037971 – IRSN/2015-00010 – Report to the Advisory Committee for nuclear pressure equipment of 30 September 2015 - Analysis of the approach proposed by Areva to demonstrate the adequate toughness of the Flamanville 3 EPR vessel bottom head and vessel closure head domes.
- [6] GP ESPN opinion and recommendations of 30 September 2015, reference CODEP-MEA-2015-040055 of 1 October 2015
- [7] ASN letter to Areva NP reference CODEP-DEP-2015-043888 of 14 December 2015 – ASN position statement on the approach to demonstrate the adequate toughness of the Flamanville 3 EPR vessel bottom head and vessel closure head domes.
- [8] Note ASN/IRSN CODEP-DEP-2016-019209 – IRSN/2016-00005 – Summary report to the Advisory Committee for Nuclear Pressure Equipment of 24 June 2016 - Approach proposed by AREVA to demonstrate the adequate toughness of the Flamanville 3 EPR vessel bottom head and vessel closure head domes – Interim review
- [9] Observations of the GP ESPN of 24 June 2016 reference CODEP-MEA-2016-027702 of 7 July 2016
- [10] ASN letter to Areva NP reference CODEP-DEP-2016-031435 of 26 September 2016 – Interim review of the approach to demonstrate the adequate toughness of the Flamanville 3 EPR vessel bottom head and vessel closure head domes
- [11] Areva NP technical note reference D02-ARV-01-104-503 revision B of 27 April 2017 – Demonstration of the adequate toughness of the Flamanville 3 EPR vessel bottom head and vessel closure head domes
- [12] Areva technical note reference NP D02-ARV-01-104-502 revision B of 18 April 2017 - Summary data on transposition of results obtained on scale-one replica part to the FA3 vessel domes
- [13] Areva NP technical note reference D02-ARV-01-101-167 revision F of 24 April 2017 – Summary of mechanical tests of the FA3 EPR scale-one replica domes programme
- [14] Areva NP technical notice reference D02 – DTIMR-F-16-0424 revision B – Flamanville 3 vessel head domes – In-service inspectability
- [15] Areva NP notice reference D02-PC-16-0003 revision A – Study of vessel closure head replacement
- [16] Areva NP notice reference D02-PC-16-0004 revision A – Study of vessel bottom head replacement
- [17] Areva NP Technical Notice D02-PEE-F-15-0007 of 24 April 2015: "FA3 reactor pressure vessel (RPV) domes - Design and fabrication"
- [18] Areva NP Technical Notice D02-PEEM-F-15-0368 of 11 May 2015: "Justification procedure for the FA3 reactor pressure vessel (RPV) closure head and bottom head"
- [19] ASN letter reference CODEP-DEP-2012-046298 of 5 September 2012
- [20] Areva NP note reference PTSI/2013.0076 of 1st February 2013

- [21] Areva NP note reference TM/QURM-79 7 2054 revision 2 – qualification report on the DSR search procedure
- [22] Areva NP note reference 34296 revision 0 of 24 April 2017 - Demonstration of performance of thermography to search for flaws filled with oxides on the outer surface of the FA3 vessel bottom head
- [23] Areva NP note reference 33300 of 22 June 2016 – Technical substantiation file for UT TOFD
- [24] Areva NP note reference COXSGN/NCR0635 revision L – Visual inspection procedure for indications seen with CPA
- [25] Areva NP letter reference ARV-DEP-00630 of 20 January 2017
- [26] Areva NP letter ARV-DEP-00354 of 11 September 2015: “Areva NP undertakings concerning the GP ESPN draft report”
- [27] ASN letter of 18 May 2016 reference CODEP-DEP-2016-018803 – Follow-up to INSSN-DEP-2016-0694 inspection in Erlangen
- [28] ASN letter of 24 October 2016 reference CODEP-DEP-2016-040564 – Follow-up to INSSN-DEP-2016-0747 inspection in Saint-Marcel
- [29] ASN letter of 30 May 2017 reference CODEP-DEP-2017-010832 – Follow-up to INSSN-DEP-2017-0637 inspection in the Areva NP Creusot Forge plant
- [30] Monitoring report by Bureau Veritas Exploitation reference RF_16-135_2540681_RJA_EC vessel head dome CODEP-DEP-2012- 052493_Rev00 of 12 February 2016
- [31] Monitoring report by Bureau Veritas Exploitation reference PV_CB797994_MCF_17-038_Synthese PEC FA3_rev03 of 24 May 2017
- [32] EDF technical notice reference D309516018651 revision A of 24 August 2016 – Potential impact of an ageing mechanism at temperature on the behaviour of a positive macrosegregation zone on the Flamanville 3 vessel head domes
- [33] EDF technical notice reference D309517011019 A of 27 April 2017 – Flamanville 3 scale-one replica domes programme – Thermal ageing programme on a positive macrosegregation zone
- [34] Areva NP technical notice reference MDHTIM 2015-034 A of 30 July 2015 – Standards used in the scale-one replica programme
- [35] Areva NP technical notice reference D02-PEEM-F-16-0291 A of 14 June 2016 – Parameters influencing the brittle fracture strength of massive forgings made of low alloy steel
- [36] Areva NP technical notice reference MDHTDM DT 14.028 A of 8 December 2014 – Results of additional tests performed on a UA dome core sample
- [37] Areva NP technical notice reference D02-ARV-01-102-083 B of 06 February 2017 – Summary of fractographic observations of the scale-one replica parts programme for the FA3 EPR vessel head domes
- [38] Engineering Fracture Mechanics 73 (2006) 2723–2747
- [39] PVP2014-28076, PVP conference 2014, Anaheim, USA
- [40] Engineering Fracture Mechanics 73 (2006) 283–295
- [41] Engineering Fracture Mechanics 69 (2002) 451–481
- [42] Article by S. Chapuliot, M.H. Lacire, S. Marie, M. Nédélec, published in 2005 in Engineering Fracture Mechanics, pp. 661-673: “Thermomechanical analysis of thermal shock fracture in the brittle/ductile transition zone. Part I: description of tests”
- [43] Areva NP note reference D02-ARV-01-104-034 revision A of 16 December 2016 - EPRTM FA3 Vessel head domes – Summary report on hot shock situations for analysis of vessel head dome outer surface flaws

- [44] Areva note reference NP D02-ARV-01-104-034 revision C of 12 June 2017 - EPRTM FA3 Vessel head domes – Summary report on hot shock situations for analysis of vessel head dome outer surface flaws
- [45] Areva NP note reference NEPRFDC81J of 10 September 2015 – File of main primary system category 2 situations
- [46] Areva NP note reference NEPRFDC82J of 17 September 2015 – File of main primary system category 3 and 4 situations
- [47] Areva NP letter reference ARV-DEP-00324 of 17 July 2015 – FA3 – Vessel head domes – Reply to JTS3
- [48] Minutes of IRSN/PSN-SRDS/2016-00019 meeting of 25 May 2016 – FA3 EPR – Vessel head domes – Situations – Meeting of 17 February 2016
- [49] Areva NP letter reference ARV-IRS-00007 of 14 October 2016 – FA3: Vessel head domes – Answer to question Q1 of letter IRSN PSN-SRDS 2016-00018
- [50] Areva NP note reference BUCLGN-NCR3087B of 7 December 2016 – Inner surface surface-breaking flaws stability analysis
- [51] Areva NP note reference BUCLGN-NCR3040B of 7 December 2016 – FA3 EPR – Vessel head domes – Stability analysis of flaws positioned at three-quarters thickness starting from the outer surface
- [52] Areva NP letter reference ARV-DEP-00633 of 25 January 2017 – FA3: Vessel head domes – Reply to IRSN question 8 on the closure of the PZR valve after unscheduled opening
- [53] Areva NP letter ARV-IRS-00010 of 10 February 2017 – FA3 – Substantiation of vessel head domes – Answers to IRSN questions on cold overpressure
- [54] Areva NP letter ARV-IRS-00011 of 21 February 2017 – FA3 – Vessel head domes – Reply to request for additional information
- [55] Areva NP note reference D02 DTIPR-F-16-0344A of 27 October 2016 – FA3 EPR – Substantiation of vessel head domes – Thermohydraulic description of the rod ejection transient (45 cm²)
- [56] Areva NP letter reference ARV-IRS-00013 of 23 March 2017 - FA3: vessel head domes – Examination of hot and cold shocks – Replies to actions of the meeting of 2 March 2017
- [57] Areva NP letter reference ARV-IRS-00016 of 31 March 2017 – FA3: Vessel head domes – replies to questions 6, 7, 9, 10, 11 and 12 of the IRSN letter (PSN-RES/SEMIA/2017-000111)
- [58] Minutes ASN-DEP-ARV-ARV-00831 of 5 April 2017 – FA3: Vessel head domes – Hot and cold shocks – Minutes of meeting of 2 March 2017
- [59] Areva NP letter reference ARV-IRS-00021 of 13 April 2017 – FA3: Vessel head domes – Justification of profile for resumption of natural circulation in the hot shock studies
- [60] Areva NP letter reference ARV-IRS-00022 of 19 April 2017 – FA3: Vessel head domes – Replies to additional IRSN questions on the cold overpressure situations in an additional transient
- [61] Areva NP letter reference ARV-IRS-00023 of 19 April 2017 – FA3: Vessel head domes – Reply to action 2 of the conclusions statement of 3 April 2017
- [62] Areva NP letter reference ARV-IRS-00024 of 20 April 2017 – FA3: Vessel head domes – Reply to action 4 of the conclusions statement of 3 April 2017
- [63] EDF letter reference D455016052320 of 23 August 2016 – Risk of residual positive carbon macrosegregation of steam generator channel heads
- [64] Report US-NRC NUREG-1806 — Technical Basis for Revision of the Pressurized Thermal Shock (PTS) Screening Limit in the PTS rule (10CFR 50.61)

- [65] Minutes reference ASN-DEP-ARV-00851 of 8 June 2017 – FA3: Vessel head domes demonstration file – Hot and cold shocks – Minutes of meeting of 7 April 2017
- [66] Minutes ASN-DEP-ARV-ARV-00840 of 27 April 2017 – FA3: Vessel head domes – Minutes of meeting IRSN/ASN-DEP/EDF/Areva NP of 3 April 2017
- [67] Areva NP note reference D02-ARV-01-110-535A of 5 May 2017 – EPRTM FA3 Vessel – Vessel head domes – Dome inner surface surface-breaking flaw stability analysis
- [68] Article S. Chapuliot - International journal of pressure vessels and piping – pp. 11-18 – March 2016: “Stress intensity factor calculation in sharp and beveled edge nozzle”
- [69] Areva NP reference D02-PEER-F-16-0173 A – Tool for fast fracture of the dome
- [70] Areva NP note reference NEPR-F DC 81 D of 24 October 2008 – FAE EPR - File of main primary system category 2 situations
- [71] Book H. Tada, P.C. Paris, G. Irwin – The stress analysis of cracks handbook – 3rd edition
- [72] Areva NP note ARV-DEP-00726 of 28 April 2017 – Vessel head domes – Fm/FmR for all index temperatures
- [73] Areva NP note reference ARV-DEP-00678 of 21 March 2017 – Reply to point AM4 of the log of open points for vessel head domes
- [74] Areva NP letter reference ARV-IRS-00016 of 31 March 2017 – FA3: Vessel head domes – replies to questions 6, 7, 9, 10, 11 and 12 of the IRSN letter (PSN-RES/SEMIA/2017-000111)
- [75] Areva NP letter reference ARV-IRS-00021 of 13 April 2017 – FA3: Vessel head domes – Justification of profile for resumption of natural circulation in the hot shock studies
- [76] Areva NP letter reference ARV-IRS-00025 of 20 April 2017 – FA3: Vessel head domes – RIS-RA connection in RA mode – Replies to questions Q1 and Q2
- [77] EDF note reference D305116045344 index A
- [78] EDF note reference D458517029486 of 6 June 2017 – EDF positions and actions concerning in-service monitoring of the Flamanville 3 reactor pressure vessel closure head and bottom head
- [79] EDF note reference D458517029054 of 6 June 2017- EDF positions and actions concerning thermal ageing
- [80] Areva NP note reference ARV-DEP-00755 of 6 June 2017 – Letter of undertakings from Areva NP
- [81] EDF note reference D458517030291 of 9 June 2017- – EDF positions and actions concerning in-service inspection of the Flamanville 3 reactor pressure vessel closure head
- [82] Areva NP letter reference ARV-IRS-00031 of 30 May 2017 – FA3: Vessel head domes – Reply to recommendation n°4 of the ASN IRSN draft report for the Advisory Committee of 26-27 June 2017 (version of 26/05/2017)
- [83] Areva NP letter reference ARV-IRS-00032 of 31 May 2017 – FA3: Vessel head domes – Reply to recommendation n°6 of the ASN IRSN draft report for the Advisory Committee of 26-27 June 2017 (version of 26/05/2017)
- [84] Areva NP letter reference ARV-IRS-00033 of 6 June 2017 – FA3: Vessel head domes – Reply sheet to recommendation n°8 of the draft report intended for the GP ESPN
- [85] EDF letter reference D458517029531 of 6 June 2017 – FA3 EPR – GP ESPN of 26 and 27 June 2017 devoted to analysis of the consequences of the anomaly in the Flamanville EPR reactor pressure vessel head domes on their serviceability – EDF positions and actions concerning the exhaustiveness of the list of thermal shock situations on the EPR reactor pressure vessel head domes

- [86] Areva NP letter reference ARV-IRS-00034 of 9 June 2017 – FA3: Vessel head domes
– Reply sheet to recommendation n°9 of the draft report intended for the GP ESPN

Acronyms, abbreviations and designations

| | |
|-------|---|
| AAC: | Hot shutdown |
| AAF: | Cold shutdown |
| LOCA: | Loss of coolant accident |
| ASG: | Steam generators emergency feedwater system (EFWS) |
| ASME: | American Society of Mechanical Engineers |
| ASTM: | American Society for Testing and Material |
| ASN: | French nuclear safety regulator |
| BC: | Hot leg |
| BF: | Cold leg |
| CCAP: | Central committee for pressure equipment |
| CIR: | Infrared combustion (IRC) |
| CN: | Natural circulation |
| CPA: | Active photothermal camera |
| CPP: | Main Coolant System (MCS) |
| CT: | “Compact tension” test specimen for toughness tests |
| DDS: | Inventory of design transients |
| DEP: | ASN Nuclear Pressure Equipment Department |
| DIDR: | Flaw due to intergranular decohesion |
| DSR: | Under cladding flaw |
| EDG: | Rod ejection |
| EPR: | European pressurized reactor |
| ESPN: | Nuclear Pressure Equipment |
| FA3: | Flamanville NPP reactor N° 3 |
| GMPP: | Reactor main coolant circulation pump (MCCP) |

GP ESPN: Advisory Committee of Experts for Nuclear Pressure Equipment

SG: Steam Generator

ICP-AES: Inductively coupled plasma atomic emission spectroscopy

IJPP: Injection at reactor main coolant pump (MCCP) seals

BNI: Basic Nuclear Installation

Inf/Lwr : Lower dome (vessel bottom head)

IRSN: French Institute for Radiation Protection and Nuclear Safety

IS: Safety injection (SI)

ISBP: Low head safety injection (LHSI)

ISMP: Medium head safety injection (MHSI)

$J_{0.2}$: Resistance to ductile tearing measured for propagation of 0.2 mm (in $N.m^{-2}$)

JSW: Japan Steel Works

K_{CP} : Stress intensity factor (in $MPa.m^{0.5}$)

K_{JC} : Toughness (in $MPa.m^{0.5}$)

LSD: Directional solidification ingot

MIS: In-service inspection machine

MWe: Megawatt electrical

N4: 1450 MWe EDF French reactors (Civaux 1 and 2, Chooz B1 and B2)

NDT: Nil Ductility Transition

PTAEE: Loss of off-site electrical power supplies (LOOP)

PKL: Experimental installation representing a reduced scale German Konvoi type PWR reactor

PSC: Upper core plate

PZR: Pressuriser

RRC: Risk Residual Category

RCC-M: Design and construction rules for mechanical equipment on nuclear islands published by the French association for design, construction and in-service

| | |
|--------------|---|
| | monitoring rules for NSSS equipment (AFCEN) |
| RCN: | Resumption of natural circulation |
| RCP: | Main Coolant System (MCS) |
| RDS: | Safety analysis report |
| PWR: | Pressurised Water Reactor |
| RGE: | General operating rules |
| RIS-RA: | Safety injection and residual heat removal system |
| RIC: | Core internal instrumentation |
| R_m : | Tensile strength (in MPa) |
| RRA: | Residual heat removal system (RHRS) |
| RRI: | Component cooling water system (CCWS) |
| $R_{p0.2}$: | Yield strength for deformation of 0.2 % (in MPa) |
| RSE-M: | In-service monitoring rules for mechanical equipment on nuclear islands of pressurised water reactors published by the French association for design, construction and in-service monitoring rules for NSSS equipment (AFCEN) |
| RT_{NDT} : | Reference Temperature for Nil Ductility Transition, deduced from T_{NDT} and T_{CV} according to section MC1240 of the RCC-M code (in °C) |
| RTV: | Steam line break (SLB) |
| SEO: | Optical emission spectrometry (OES) |
| SPN: | CCAP standing nuclear section |
| STE: | Operating Technical Specifications |
| Sup/Upr: | Upper dome (vessel closure head) |
| T_0 : | Reference temperature for indexing the Master Curve, defined according to standard ASTM E1921 (in °C) |
| T_{68j} : | Temperature taken from the bending rupture energy transition curve for which the average bending rupture energy is 68 J (in °C) |
| T_{CV} : | Temperature taken from the bending rupture energy transition curve for which the minimum bending rupture energy is 68 J (in °C) |
| T_{env} : | Index temperature of the toughness curve of appendix ZG of the RCC-M code |

providing an optimum conservative value for the toughness measurements (in °C)

- T_{NDT} : Temperature for Nil Ductility Transition, deduced from the drop-weight tests according to section MC1230 of the RCC-M code (in °C)
- TK_{56J} : Temperature taken from the bending rupture energy transition curve for which the average bending rupture energy is 56 J (in °C)
- TOFD: Ultrasounds using the “time of flight diffraction” technique
- UA: Scale-one replica dome called UA
- UK: Scale-one replica dome called UK
- UT: Ultrasounds
- VDA: Main steam relief train (MSRT) valve
- VVP: Main steam system
- ZR: Acceptance zone
- ZS: Segregation zone

1. Introduction

The Flamanville EPR reactor pressure vessel closure and bottom head domes were manufactured in 2006 and 2007 by forging in the Areva NP Creusot Forge plant.

These components are subject to the technical qualification requirement¹ of the ESPN order in reference [3] because they present a risk of heterogeneity in their properties.

For the purposes of this technical qualification, Areva NP measured bending rupture energy values² lower than those mentioned in point 4 of appendix I to the ESPN order in reference [3], which led it in 2015 to propose an approach to ASN to demonstrate the adequate toughness of the material of these components, based on a programme of testing on scale-one replica domes and mechanical assessments of the risk of fast fracture.

This approach was examined by ASN and the French institute for radiation protection and nuclear safety (IRSN) and written up in the report in reference [5], was the subject of an opinion in reference [6] of the Advisory Committee of experts for nuclear pressure equipment (GP ESPN), which met on 30 September 2015, and of ASN requests, more specifically concerning the in-service inspection provisions, in its letter in reference [7]. Subject to these requests being taken into account, ASN considered that the demonstration approach is appropriate, provided that the phenomenon in question is identified and explained and that the data acquired through the test programme are sufficient to characterise it.

The first test results, in April 2016, led Areva NP to change its demonstration approach, notably the test programme on scale-one replica domes, which gave rise to an information meeting with the GP ESPN on 24 June 2016, on the basis of the summary report drawn up by ASN and IRSN in reference [8].

On the basis of the observations of the GP ESPN in reference [9], ASN informed Areva NP of additional requests in its letter in reference [10].

*

The Areva NP test programme was conducted for the most part in 2016. On 16 December 2016, Areva NP sent ASN a file in reference [11] substantiating the fact that the material of the Flamanville EPR reactor pressure vessel head closure and bottom head domes is ductile and tough enough to deal with the operating conditions of this equipment. This file more particularly draws on the results of the mechanical tests and concludes that the domes are serviceable.

In its letter in reference [7], ASN informed Areva NP that it considered that the technical qualification requirement of the ESPN order in reference [3] was not met for the domes, because the heterogeneity risk had been poorly assessed and the characteristics of the material were not as expected.

¹ Technical qualification is a regulatory requirement of the ESPN order in reference [3], the aim of which is to demonstrate that the risks of heterogeneity in the expected quality of the component are identified and controlled and to ensure that the component has the required characteristics.

² The bending rupture energy is the ability of a material to absorb energy when it deforms under the effect of an impact. It is relatively simple to measure. This property is thus commonly used by industry to evaluate the quality of a material.

Areva NP thus envisages sending ASN a commissioning authorisation application for the Flamanville EPR reactor pressure vessel, even though it has not met all the regulatory requirements, pursuant to article 9³ of the ESPN order in reference [3]. This report is a part of the advance technical examination of this authorisation application.

In its letter in reference [7], ASN informed Areva NP that such an application needed to be substantiated with regard to the advantages and drawbacks of alternative solutions, notably repair of the reactor pressure vessel and replacement of the closure head.

Areva NP considers that procurement of a new closure head and replacement of the existing one, an operation that has already been carried out on several reactors, would take at least 75 months. Areva NP and EDF also examined the possibility of repairing the reactor pressure vessel bottom head and consider that the consequences would be disproportionate in terms of cost, lead-time and consequences for the EPR reactor model and the nuclear reactor system. Repair would entail extracting the reactor pressure vessel from its cavity, replacing its bottom head, reinstalling it and rebuilding a part of the surrounding civil engineering structures. These operations are estimated to take 86 months. These various aspects, which are not examined within the framework of this report, are detailed in Appendix 7.

*

ASN decided to convene the GP ESPN on 26 and 27 June 2017 to obtain its technical opinion on the consequences of the anomaly on the serviceability of the Flamanville EPR reactor pressure vessel head domes.

*

This report recalls the approach adopted by Areva NP to demonstrate that the material of the Flamanville EPR reactor pressure vessel head domes is ductile and tough enough for the operating conditions of this equipment and evaluates whether or not the anomaly compromises their serviceability. It deals in turn with the demonstration approach adopted by Areva NP, the fast fracture risk assessment (manufacturing inspections, material characterisation, characterisation of thermomechanical loadings and mechanical analysis), the impact of the irregularities detected in the Areva NP Creusot Forge plant and the in-service monitoring provisions.

This report was drawn up jointly by IRSN and the Nuclear Pressure Equipment Department (DEP) of ASN. The term “rapporteur” used in this report, thus refers irrespectively to the specialists of IRSN and of ASN who analysed the Areva NP file for presentation to the GP ESPN on 26 and 27 June 2017. It does not represent the final position that will be adopted by ASN.

³ Article 9 of the ESPN order in reference [3]: *“Pursuant to article R. 557-1-3 of the Environment Code, in the event of a particular difficulty and a duly justified request, more specifically ensuring that the risks are adequately prevented or mitigated, ASN may, in a resolution issued on the advice of the central committee for pressure vessels, authorise the installation, start-up, utilisation and transfer of a nuclear pressure equipment or nuclear assembly which has not met all the requirements of Articles L. 557-4 and L. 557-5 of the Environment Code, chapter VII of title V of book V of the regulatory part of the Environment Code and this present order.*

The request must be accompanied by an analysis, conducted jointly with the licensee, of the actual and potential consequences with regard to the protection of the interests mentioned in article L. 593-1 of the Environment Code. [...]”

2. Demonstration approach

2.1. Detection of the deviation and technical origin

The Flamanville EPR reactor pressure vessel closure head and bottom head domes (see Figure 1 and the detailed diagrams in Appendix 2) were manufactured in 2006 and 2007 by forging. These components are subject to the technical qualification requirement of the ESPN order in reference [3] because they represent a risk of heterogeneity in their characteristics.

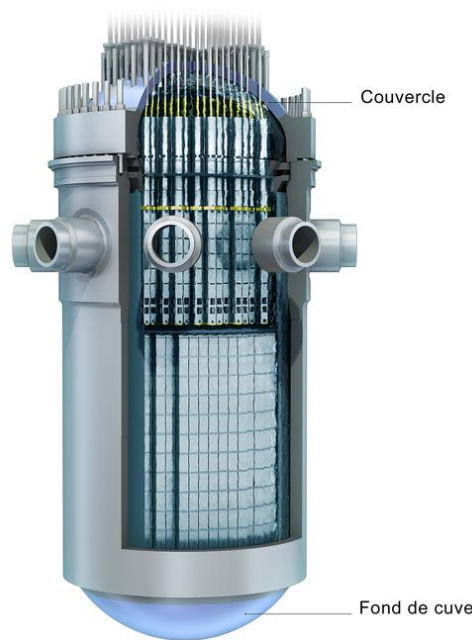

Figure 1: Representation of the Flamanville EPR reactor pressure vessel
Closure head
Bottom head

At the end of 2014, Areva NP informed ASN that the results of the impact tests were lower than expected. The tests were carried out as part of the technical qualification process on specimens sampled from a dome initially intended for an EPR reactor project in the United States, called the UA closure head dome, in principle representative of those intended for the Flamanville EPR reactor pressure vessel. The values measured at 0°C on two series of three specimens gave a minimum value of 36 J and an average value of 52 J which were unable to achieve the quality then expected by Areva NP. These values are also below the bending rupture energy value of 60 J mentioned in point 4 of appendix I to the ESPN order in reference [3].

Areva NP carried out investigations to determine the origin of these non-conforming values. The carbon concentration measurements taken at the surface of the UA upper dome by portable optical spectrometry revealed the presence of a residual positive macrosegregation zone over a diameter of about one metre. Furthermore, the examinations performed on the material sampled at depth, in the centre of this dome, show that the segregation extends to a depth exceeding the half-thickness of the dome.

Areva NP explains that the residual positive macrosegregation from the ingot used in forging was not sufficiently eliminated during the discard operations. The manufacturing procedures for the domes is recalled in Appendix 8 and the position of the positive macrosegregation during forging is presented in Figure 2.

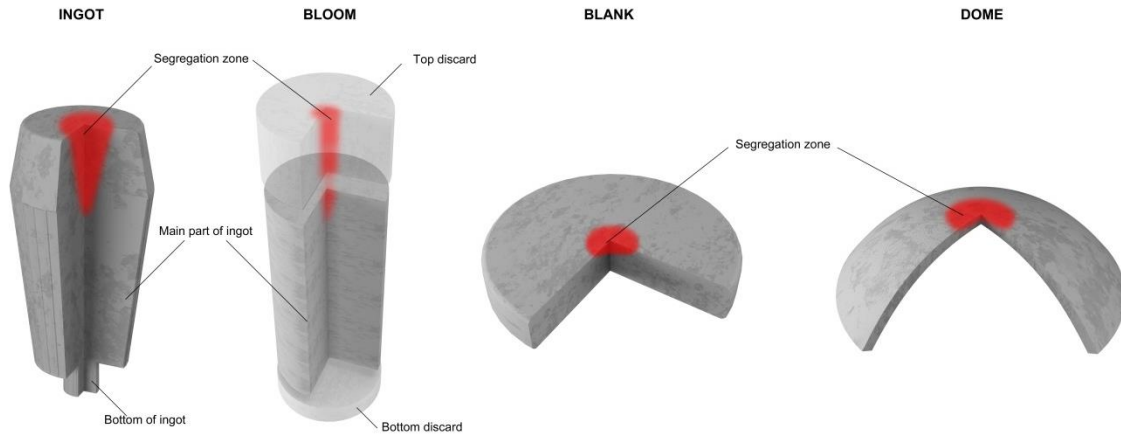

Figure 2: Position of positive macrosegregation during forging

The physical phenomenon of segregation occurs at cooling of the ingot, which does not take place uniformly. After pouring and solidification of the steel, the large-sized ingots thus comprise macroscopic heterogeneities in their chemical composition, in particular their carbon concentration (Figure 3).

Generally speaking, in this type of ingot, the base is the part which solidifies first and leads to a negative macrosegregation zone (concentration of alloy elements lower than the average heat of steel value). On the other hand, the top of the ingot solidifies last and is where positive macrosegregation occurs (higher concentration than the average heat of steel value).

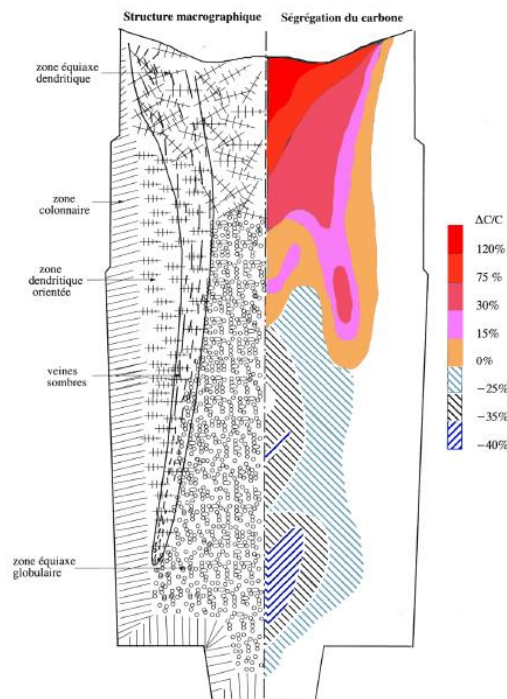

Figure 3: Structure and carbon segregation in a conventional ingot

Macrographical structure
Dendritic equiaxed zone
Columnar zone

Carbon segregation

Oriented dendritic zone
Ghost lines
Globular equiaxed zone

A positive macrosegregation zone is thus characterised by a local carbon content that is higher than the target average level at pouring of the liquid steel. The segregation ratio is then the ratio by which the local content exceeds the target content ($\Delta[C]/[C]_{\text{heat of steel}}$).

The normal carbon content of a 16MND5 type steel, such as that used in the Flamanville EPR reactor pressure vessel, is 0.16%. The RCC-M code defines a maximum content of 0.20% at pouring and a maximum part content of 0.22 %⁴. For the purposes of this file, the volume of material of interest for assessing the mechanical properties of the positive macrosegregation zone was defined as that with a carbon content in excess of 0.25% [5].

An increase in the carbon concentration leads to improved tensile strength properties, but affects the crack propagation resistance.

2.2. Principles of the Areva NP demonstration approach

2.2.1. Degradation modes selected

As previously mentioned, the assessments carried out on the UA scale-one replica showed material bending rupture energy properties that were lower than expected. As the level of bending rupture energy is an indicator of the level of toughness⁵, the toughness of the segregation zone could thus be insufficient to preclude the risk of fast fracture at the temperatures to which the steel is subjected.

Areva NP considers that the presence of a positive macrosegregation zone does not compromise the prevention of excessive deformation damage, progressive deformation and plastic instability of the reactor pressure vessel domes. The design criteria with respect to these risks are dependent on the yield strength and the ultimate tensile strength of the material, which increase with the carbon content. The rapporteur adopts a position on this point in section 4.3.8.

The Areva NP file in reference [11], thus focuses on the preclusion of the risk of fast fracture. This risk exists if there is a combination of three phenomena:

- the presence of a harmful technological flaw (defined by its position, its orientation and its dimensions);
- the presence of an insufficiently tough material;
- the presence of large-scale mechanical or thermal loadings.

The toughness of the steel used to manufacture a reactor pressure vessel varies with the temperature of the material. The Areva NP approach thus differs depending on whether the material is used:

- in the temperature domain in which it is brittle and in which its toughness is lowest,

⁴ For the domes of the Flamanville EPR reactor pressure vessel, Areva NP aimed for a value at pouring of 0.18%, in order to guarantee acceptable tensile properties at the base of the ingot.

⁵ Toughness is the ability of a material to withstand crack propagation. This is the property which intervenes in the fast fracture phenomenon.

- known as the *brittle domain*;
- in the temperature domain corresponding to the transition between brittle and ductile behaviours, known as the *brittle-ductile transition domain*, in which the toughness increases with temperature;
- in the temperature domain in which it is ductile and where its toughness is highest, known as the *ductile domain*.

2.2.2. Assessment of the fracture risk in the brittle and brittle-ductile transition domains

With regard to the brittle and brittle-ductile transition domains, the demonstration approach followed by Areva NP, presented in the document in reference [17], comprises three main steps:

- the evaluation (by testing) of the minimum toughness in the positive macrosegregation zone of the material, after 60 years of operation;
- the determination (by calculation) of the adequate (also known as allowable or required) toughness to preclude the risk of fast fracture;
- the verification that the minimum toughness of the material is indeed higher than the determined adequate toughness.

As presented by the rapporteur in 2015 in its report in reference [5], Areva NP adopts the approach of appendix ZG of the RCC-M code to model the toughness of the material as a function of temperature. This single parameter model is based on the ZG 6110 curve (see Figure 4) which must be indexed with the brittle-ductile transition temperature (RT_{NDT} ⁶) of the material. In this approach, the toughness of the material is thus characterised by its RT_{NDT} .

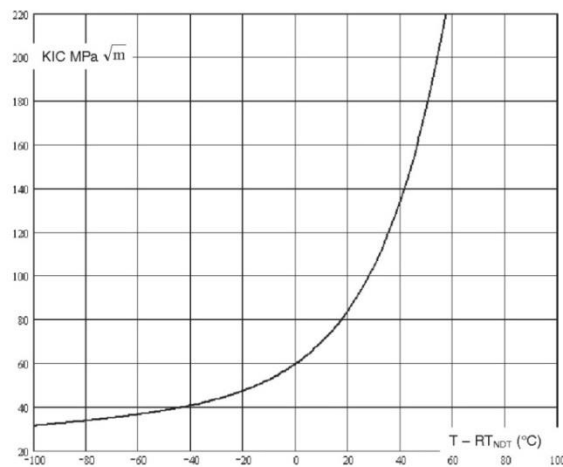

Figure Z G 6110
Courbe de ténacité de référence des aciers faiblement alliés couverts par les spécifications M.2110 et M.2120

L'expression analytique de la courbe est la suivante, dans le domaine $T - RT_{NDT} \leq 60^\circ\text{C}$.

$$K_{IC} = 40 + 0,09 (T - RT_{NDT}) + 20 e^{0,038 (T - RT_{NDT})}$$

où K_{IC} est exprimé en $\text{MPa}\sqrt{\text{m}}$, et T ainsi que RT_{NDT} sont exprimés en $^\circ\text{C}$.

Figure 4: ZG 6110 curve of the RCC-M code

Reference toughness curve for low alloy steels covered by specifications M.2110 and M.2120

The analytical expression of the curve is as follows, in the domain.....

.....

where K_{IC} is expressed in and T and RT_{NDT} are expressed in $^\circ\text{C}$

⁶ Reference Temperature for Nil Ductility Transition, deduced from the drop-weight and impact tests according to section MC1240 of the RCC-M code. The drop-weight test is an impact bending test on a rectangular specimen with a weld bead pre-notched with a saw.

According to this approach, the effect of the positive macrosegregation, which tends to reduce the toughness at a given temperature, also leads to an increase in the reference temperature RT_{NDT} (Figure 5).

In 2015, Areva NP had initially estimated that the shift would be less than 70°C and more probably about 35°C for the steels used in the Flamanville EPR reactor pressure vessel head domes, based on the impact tests performed on the material sampled from the centre of the UA upper dome.

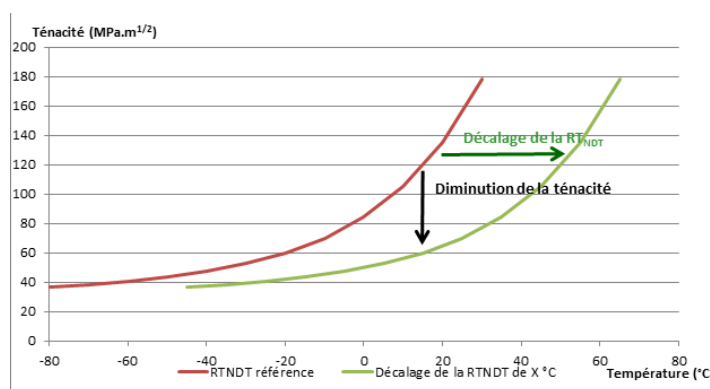

Figure 5: Effect of transition temperature shift on toughness

Effect of shift of transition temperature on toughness

Toughness (Mpa....)

Shift of

Toughness reduction

Reference RTNDT Shift of RTNDT by X°C Temperature (°C)

2.2.2.1. Determination of minimum toughness and mechanical properties in the positive macrosegregation zone

In the Areva NP demonstration file, the determination of the mechanical properties of the material in the positive macrosegregation zone and the minimum toughness in particular, is based on the results of a test programme run on three scale-one replica domes. These tests, most of which are destructive, cannot be carried out directly on the domes of the Flamanville EPR reactor pressure vessel domes.

The use of scale-one replica domes requires that Areva NP demonstrate that they are representative of the domes of the Flamanville EPR reactor pressure vessel heads.

Experimental programme

The objective of the test programme proposed by Areva NP, presented in the document in reference [17], is to evaluate:

- the scope and the level of the carbon in the segregation zone, in order to locate the material of use for the mechanical properties characterisation tests;
- the mechanical properties of the material in these areas of interest, affected by positive macrosegregation and mainly its toughness.

Three scale-one replica domes were selected:

- an upper dome initially forged for the Hinkley Point EPR reactor project (UK upper

- dome, called “UK upr” in the rest of the report);
- a lower dome initially forged for an EPR reactor project in the United States (UA lower dome, called “UA lwr” in the rest of the report);
- an upper dome initially forged for the same reactor project in the United States (UA upper dome, called “UA upr” in the rest of the report); Tests performed on a core sample taken from the centre of this dome, are the origin of the detection of the anomaly at the end of 2014. This core sample was added to the programme in 2016 by Areva NP following the first results.

The test programme is presented in detail in part 4.1 of this report.

Representativeness of the scale-one replica domes

The demonstration by Areva NP that the scale-one replica domes are representative of the domes of the Flamanville EPR reactor pressure vessel head domes, presented in reference [12], relies on the analysis of two factors, linked to the manufacturing process and which are predominant with regard to the risk of fast fracture:

- the carbon content;
- the quenching effect⁷, characterised by the cooling rate during quenching.

Areva NP also compared the mechanical properties in the acceptance zone of each of the domes, including that of the Flamanville EPR reactor pressure vessel.

The demonstration of the representativeness of the various domes is detailed in part 4.2 of this report.

2.2.2.2. Determination of the adequate toughness to demonstrate the preclusion of the risk of fast fracture

The adequate toughness was defined by Areva NP in 2015 as a minimum material toughness value capable of meeting the criteria of Appendix ZG of the RCC-M code to preclude the risk of flaw initiation. This minimum value is calculated by considering:

- the largest technological flaw potentially present in the reactor pressure vessel closure head and bottom head (see part 3);
- the loads to which the flaws are subjected in the various operating situations (see part 5);
- the safety coefficients provided for in appendix ZG of the RCC-M code, which are dependent on the situation category (see part 6).

2.2.2.3. Comparison between the minimum toughness and the adequate toughness

After determining the minimum toughness of the material and the adequate toughness to demonstrate the preclusion of the fast fracture risk, Areva NP verifies that the first is indeed greater than the second (see Figure 6). This comparison can also be used to determine the margins with respect to the risk of fracture initiation.

⁷ For a steel such as 16MND5, quenching improves the toughness and impact strength properties.

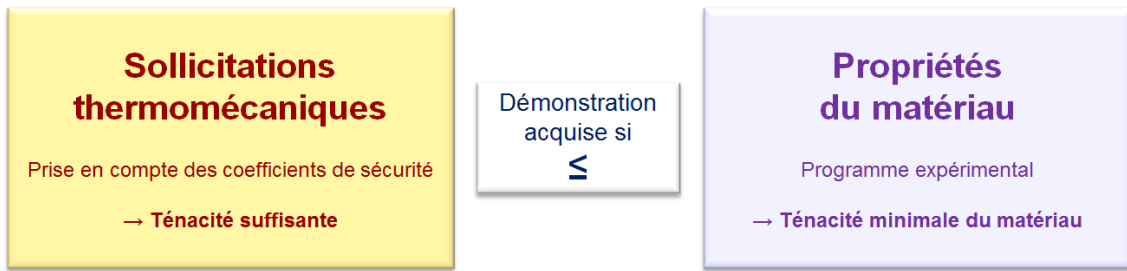

Figure 6: General demonstration approach

| | | |
|----------------------------------|----------------------------|----------------------------|
| Thermomechanical loads | Demonstration confirmed if | Material properties |
| Inclusion of safety coefficients | | Experimental programme |
| Adequate toughness | | Material minimum toughness |

2.2.3. Fracture risk assessment in the ductile domain

Areva NP verifies the correct behaviour of the reactor pressure vessel head domes in the ductile domain by evaluating the toughness of the material on the basis of tearing tests on toughness specimens produced at 50°C and 330°C in order to cover all the temperatures encountered in a reactor operating situation.

Areva NP directly compares the toughness values resulting from the tearing tests at these temperatures:

- with the values codified in appendix ZG of the RCC-M code;
- if the values codified in appendix ZG of the RCC-M code are not reached, at the maximum loading calculated for a crack postulated in the zone of interest for all operating situations.

2.3. Position statements by ASN since 2015

2.3.1. ASN position statement following the GP ESPN meeting of 30 June 2015

The approach proposed by Areva NP in 2015 in the documents in references [17] and [18] was the subject of an initial review by the rapporteur presented in the report in reference [5] and an examination by the GP ESPN on 30 September 2015 which returned an opinion in reference [6] on the following points:

- the acceptability in principle of an approach designed to demonstrate the adequate toughness of the Flamanville EPR vessel closure head and bottom head domes;
- the notion of adequate material toughness proposed by Areva NP and its method of determination;
- the method of determination of minimum material toughness, which is mainly based on a test programme, in particular the transposition to the Flamanville EPR reactor pressure vessel domes of the results obtained on other domes;
- the comparison between the minimum toughness of the material and the adequate toughness, in particular the associated criteria.

On the basis of this review and this opinion, ASN issued a position statement regarding this approach and presented its observations and its requests in the letter of 14 December 2015 in reference [7].

Provided that its observations and requests are taken into account, ASN informed Areva NP that it would consider the demonstration approach to be appropriate, on condition that the

phenomenon in question is identified and explained and that the knowledge acquired via the test programme is sufficient to characterise the material.

The ASN requests more specifically concerned the in-service monitoring provisions to be implemented on the reactor pressure vessel head domes (see chapter 8).

ASN also underlined that this demonstration approach was based on the assumption of satisfactory mechanical properties at mid-thickness - notably in terms of toughness - and that if this hypothesis were not to be confirmed by the results of the tests performed on the scale-one replica domes, the demonstration file would need to be added to. As of the beginning of 2016, Areva NP revealed that the segregation exceeded mid-thickness of the domes and thus had to modify its demonstration approach.

2.3.2. ASN position statement following the GP ESPN meeting of 24 June 2016

The changes to the approach proposed by Areva NP and to the test programme, along with the first results, led to an GP ESPN information meeting on 24 June 2016, based on the summary report drawn up by the rapporteur in reference [8].

On the basis of the observations of the GP ESPN in reference [9], ASN informed Areva NP of additional requests in its letter in reference [10] and indicated to Areva NP that it had no objection to the addition of a third dome to the test programme and to the changes such as to substantiate the file concerning the representativeness of the scale-one replica domes.

In the letter in reference [10], ASN also asked Areva NP to extend the fast fracture risk assessments to the postulated inner surface flaws, under the cladding.

The table in Appendix 15 gives the requests in the letters in reference [7] and [10], the undertakings made by Areva NP in the letter in reference [26] and the references of its replies.

3. Inspection by non-destructive testing during manufacturing: search for flaws potentially present in the reactor pressure vessel closure head and bottom head

3.1. Recapitulation of requests made by ASN following the GP ESPN sessions of 30 September 2015 and 24 June 2016

In the technical documentation for the domes of the Flamanville EPR reactor pressure vessel, Areva NP specifies the unacceptable flaws as defined in requirement 3.4 of appendix I of the ESPN order in reference [3]. These flaws are recalled in Table 1.

| Flaws | Origin | Characteristics (end of manufacturing) | Quantitative and qualitative definition of unacceptable flaws |
|--------------------------------------|--|--|--|
| Surface-breaking exogenous inclusion | Steelmaking | Linear or rounded surface flaw which can be isolated or linearly distributed | 10 isolated linear flaws of dimension greater than 2 mm within a 90° sector A cluster of 5 or more linear or rounded flaws with a dimension greater than 2 mm within a surface area of 250 cm ² |
| Exogenous inclusion in the volume | | Planar or volume flaw oriented in the fibre structure direction | 10 isolated flaws of dimension greater than 10 mm within a 90° sector A cluster of 5 or more flaws of dimension greater than 5 mm regardless of its position in the part and which cannot be circumscribed within a surface area of 250 cm ² |
| Laps-internal cracks | Forging | Surface flaw with open edges of any orientation | Any visually detectable linear flaw longer than 3 mm |
| Hydrogen related flaw | Steelmaking and precautionary heat treatment | Planar flaw parallel to the fibre structure direction | Any flaw identified as being due to hydrogen, regardless of its dimension |

Table 1: Specification of unacceptable flaws in the Flamanville EPR reactor pressure vessel domes

Areva NP implemented the following non-destructive test inspections to detect these flaws during manufacturing:

- a visual check on all surfaces during the various manufacturing and machining phases;
- a dye-penetrant inspection of the inner and outer surfaces of the domes after final machining;
- a volume inspection using longitudinal ultrasound waves (OL 0°) from the inner surface and shear waves (OT 45°) after final machining or at a stage that is as advanced as possible for the parts that cannot be inspected in the final state. Inspection by longitudinal waves was performed with a gain increased by +12 dB with respect to the gain required by the RCC-M code.

The inspection performance presented by Areva NP is as follows:

- for flaws parallel to the surfaces, detected using the OL 0° probe calibrated on a flat bottom hole of 3 mm, detectability is guaranteed for flaws of 3 mm x 8 mm for the lower dome of the Flamanville EPR reactor pressure vessel and of 3 mm x 10 mm for the upper dome of the Flamanville EPR reactor pressure vessel;

- for planar flaws perpendicular to the dome surfaces, Areva NP indicates that the detection performance remains highly dependent on the “roughness of the flaws”. If the flaw is rough, detection of a flaw of dimensions 10 mm x 20 mm is guaranteed for surface-breaking or subsurface flaws and for internal flaws, if they are not too disoriented. If the flaw is smooth, the inspections cannot guarantee detection for the dimensions corresponding to the rough surface flaw. The flaw however remains correctly detected when surface-breaking or has a small ligament⁸ in relation to the surface, including with a slight disorientation.

During the course of these inspections, Areva NP detected no indication not conforming to the criteria of the RCC-M code. Notable indications were however detected using the excess power ultrasounds inspection (gain control increased by +12 dB, not required by the RCC-M code) on the Flamanville EPR reactor pressure vessel lower dome (point indications of dimension less than 2 mm, positioned between 70 mm and 140 mm depth from the outer wall, concentrated in the centre of the dome). These inspection reports have been sent to the rapporteur.

In its report in reference [5] in preparation for the GP ESPN session of 30 September 2015, the rapporteur did not call into question the definition and substantiation of the unacceptable flaws selected by Areva NP and shared the conclusions announced by Areva NP regarding the detectability of planar flaws. It also considered that the results of the inspections make it possible to conclude with a reasonable degree of certainty that there are no unacceptable flaws in the domes.

However, with regard to the surface inspection, the rapporteur considered that the most pertinent inspection would have been magnetic particle, as required by the ASME code for the material SA 508. This surface inspection was not performed by Areva NP at the manufacturing stage. Only the visual and dye-penetrant inspections were carried out. Performance of a magnetic particle inspection would have been able to reinforce the confidence given by the other surface inspections, particularly in the case of small surface-breaking, disoriented flaws, possibly filled with oxide and having a smooth surface.

To make up for the absence of this inspection, Areva NP undertook in 2015 to provide data to demonstrate the absence of surface-breaking flaws and ASN asked Areva NP to perform non-destructive surface tests on the Flamanville EPR reactor pressure vessel lower dome, other than dye-penetrant.

Following analysis of the initial results from the test programme, Areva NP supplemented its file with the addition of flaws postulated at three-quarters thickness from the outer face. After informing the GP ESPN of these elements at the session of 24 June 2016, ASN asked Areva NP in a letter in reference [10] to carry out inspections to search for under-cladding flaws on the inner surface of the Flamanville EPR reactor pressure vessel lower dome.

⁸ The ligament refers to the portion of sound metal that exists between the top of a flaw and the surface of the part inspected. The absence of ligament or a small ligament means that the flaw is classified as surface-breaking.

3.2. Elements transmitted by Areva NP

3.2.1. Elements transmitted by Areva NP in response to its undertakings

Areva NP carried out all the non-destructive inspections it had undertaken to perform. The purpose of these inspections was to search for surface-breaking flaws not detected during dye-penetrant inspections carried out during manufacturing.

On the lower dome of the Flamanville EPR reactor pressure vessel, Areva NP carried out a long dye-penetrant inspection in March 2017, that is with a penetrant impregnation time increased to 120 minutes and a development time of between 10 and 30 minutes. For the Flamanville EPR reactor pressure vessel lower dome, Areva NP also carried out a dye-penetrant inspection in 2015 after eliminating impact points (a few tens of millimetres) due to carbon content measurements by optical emission spectrometry (see part 4.1.1.4). This dye-penetrant inspection was not performed on the Flamanville EPR reactor pressure vessel closure head owing to the risk of introducing dye-penetrant products into the gaps between the adapters and the closure head.

On the Flamanville EPR reactor pressure vessel closure head dome, Areva NP was able to carry out magnetic particle inspection on the peripheral part outside the adapters zone. In the central zone where the adapters are situated, which is also where the positive macrosegregation is to be found, this inspection was not performed for reasons of accessibility and because of the risk of introducing the inspection product (magnetic bath) into the gaps between the adapters and the closure head.

In order to consolidate its file, Areva NP also sent the rapporteur the results of the inspections performed on the UA upper dome by magnetic particle inspection and long dye-penetrant inspection and on the UA lower dome by magnetic particle inspection.

All of these inspections detected no indication exceeding the criteria of the RCC-M code. The results are presented in Table 2.

| Component | Type of inspection | Results |
|---------------------|--------------------------------------|--|
| FA3 lower head dome | Long-duration dye-penetrant | 23 March 2017 - Conforming |
| FA3 lower head dome | Dye-penetrant after spectrometry | 5 February 2015 - Conforming |
| FA3 upper dome | Magnetic particle in peripheral zone | from 22 to 24 January 2016 - Conforming |
| UA upper dome | Long-duration dye-penetrant | 25 March 2016 - Conforming |
| UA upper dome | Magnetic particle before testing | from 21 April to 3 May 2010 - Conforming |
| UA upper dome | Magnetic particle after testing | from 26 to 30 March 2016 - Conforming |
| UA lower dome | Magnetic particle before testing | from 10 to 24 October 2011 - Conforming |

Table 2: Non-destructive inspections performed as per Areva NP's undertakings

3.2.2. Elements transmitted by Areva NP in response to the requests made by ASN

3.2.2.1. *Inspections to search for under-cladding flaws on the inner surface of the Flamanville EPR reactor pressure vessel lower and upper domes*

In the letter in reference [19], ASN asked Areva NP to justify the steps taken for inspection and for prevention of under-cladding flaws on the clad components of the main primary system.

In its letter in reference [20], Areva NP identified the flaws liable to appear under the cladding of the inner surface after the welding operation. These are flaws linked to cold cracking (DSR) and grain boundary decohesion (reheat cracking) (DIDR). These flaws are preferentially situated under the cladding in the segregation zones of the base metal and oriented perpendicular to the surface of the cladding.

When the austenitic steel cladding is deposited on the lower and upper domes of the Flamanville EPR reactor pressure vessel, Areva NP followed procedures to prevent the appearance of such flaws:

- a minimum preheat temperature of 150°C;
- a maximum temperature between passes of 250°C;
- a minimum post-heating temperature of 250°C for at least four hours;
- cladding performed on the base of the domes ingot in order to be as far as possible from the carbon positive macrosegregation;
- conditions concerning overlapping of weld passes.

Areva NP verified the effectiveness of these provisions by ultrasound inspections on the first parts manufactured (same base metal, same cladding welding process and same filler metal). This verification did not however in principle concern parts with segregation zones.

ASN asked Areva NP to carry out an inspection of the same type on the domes of the Flamanville EPR reactor pressure vessel.

This inspection carried out in the factory is based on an ultrasound examination using longitudinal waves angled at 70°. The procedure for this inspection requires that the indications with an amplitude of greater than or equal to 50% of the amplitude of the echo from the reference hole (flat bottom hole with a diameter of 2 mm) be noted and then characterised. In the 1980s, Areva NP carried out tests to characterise the performance of this ultrasounds inspection and concluded that surface cracks larger than 2 mm² can be detected (value taken from the report in reference [21]). The results of these inspections performed on the domes of the Flamanville EPR reactor pressure vessel are presented in Table 3.

| Component | Type of inspection | Results |
|---|--|---|
| FA3 lower head dome (entire surface) | Ultrasounds DSR search inspection | 13 to 15 December 2016 Conforming |
| FA3 upper dome (partial inspection) | Ultrasounds DSR search inspection after stress-relieving heat treatment | 3 to 8 February 2014 Conforming |
| | Ultrasounds DSR search inspection after stress-relieving heat treatment and after elimination of ridges | 25 to 26 June 2015 Conforming |

Table 3: Non-destructive inspections performed in response to ASN requests

With regard to the upper dome, the entire surface could not be inspected. The inspected zone corresponds to 92% of the cladding of the dome. The remaining 8% corresponds to the inaccessible zones defined in Figure 7. The entire centre of the dome, over a diameter greater than 1.2 m was thus inspected, which covers the potentially segregated zone.

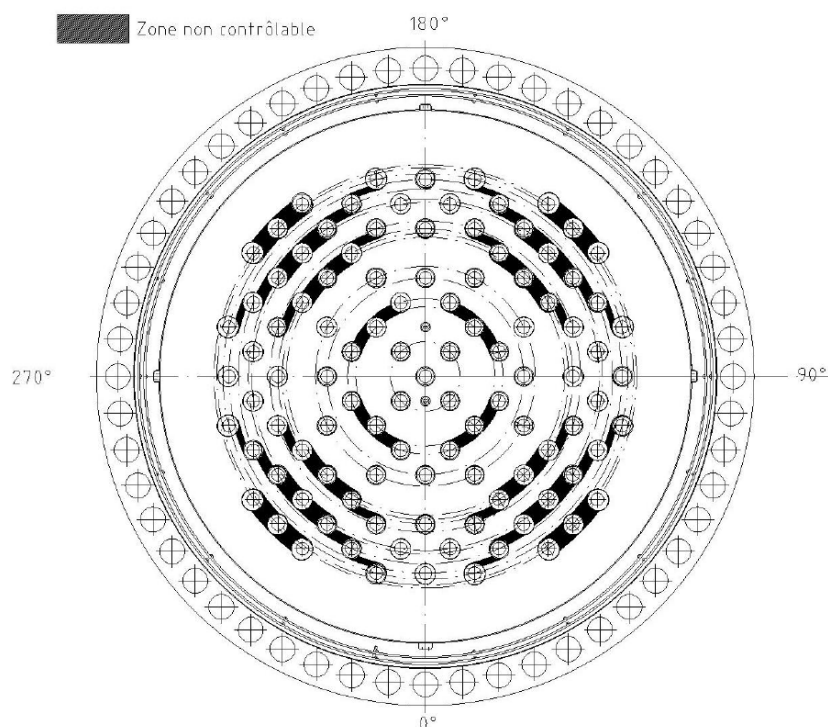

Figure 7: Areas not inspected on the upper dome of the Flamanville EPR reactor pressure vessel with regard to the search for under-cladding flaws

Non-inspectable area

3.2.2.2. Performance of non-destructive tests on the reactor pressure vessel bottom head, other than dye-penetrant

ASN asked Areva NP to carry out non-destructive inspection to make sure that the presence of oxides which appeared during steelmaking, mainly on rough surfaces, did not mask the presence of flaws during the dye-penetrant surface inspection on the lower dome⁹ of the Flamanville EPR reactor pressure vessel.

In the letter in reference [25], Areva NP specified that cracks could fill with oxides during the heating operations during forging. However, between the stage of possible appearance of these oxides and the dye-penetrant inspection stage, Areva NP indicated that a significant thickness of metal had been eliminated by machining, which renders the presence of these oxides unlikely.

Areva NP however initiated a programme of non-destructive inspections to detect such flaws, adopting a conventional qualification approach. This approach ensures that the active photothermal camera (CPA) process selected by Areva NP is able to detect surface-breaking flaws 5 mm in length, disoriented, possibly filled with oxides and possibly having a smooth surface. This technique is compared with alternative methods in Table 4.

⁹ For information, during the examination carried out in 2015, the rapporteur shared Areva NP's findings that no surface inspection in addition to those already performed could be envisaged on the outer surface of the upper dome of the Flamanville EPR reactor pressure vessel, owing to the presence of the adapters.

| Technique | Sensitivity comparable to magnetic particle | Ceiling inspection | Justification of detection of flaws filled with oxides | Ability to size indications at depth | Orientation of scan passes |
|---------------------------|---|------------------------------|--|--------------------------------------|----------------------------|
| Laser thermography | Yes | Yes | Yes | No | 0° and 90° |
| TOFD ultrasounds | Yes | Yes (management of couplant) | No | Yes | 0° and 90° |
| Creeping wave ultrasounds | Yes | Yes (management of couplant) | No | Yes | Every 15° |
| Eddy currents | Yes | Yes | No | No | 0° and 90° |
| ACFM (eddy current type) | No | Yes | No | Yes | 0° and 90° |

Table 4: Analysis of performance of non-destructive inspection methods

Areva NP opted for a TOFD (time of flight diffraction) ultrasounds technique for sizing the indications detected with the CPA method.

The CPA method consists in locally heating the surface to be inspected using a focused laser beam. The infrared emission from the surface close to the heating point is measured by an infrared detector. The flaws are detected by the thermal barrier effect created by their presence.

Areva NP conducted a programme to demonstrate the performance of thermographic inspection, presented in the document in reference [22], using mock-ups with surface-breaking type flaws of 1.5 mm x 3 mm, 2.5 mm x 5 mm and 10 mm x 30 mm, and subsurface flaws 3, 5 and 20 mm long, with ligaments varying from 0.1 mm to 1 mm. This programme also simulated the response by a notch filled with oxide and a notch filled with compacted iron ferrite powder. Areva NP concludes that all of these flaws are detectable.

During the course of this programme, Areva NP compared the detection performance of magnetic particle inspection and the CPA method. The results are presented in Table 5 and show that the discontinuities detected in magnetic particle inspection but not in CPA are those with significant ligaments and a length of less than 3 mm. This table also gives the results that would have been given by a dye-penetrant inspection, with surface-breaking notches of dimensions greater than the sensitivity of the dye-penetrant method.

| Notch ligament | Notch length | Detection by magnetic particle inspection | Detection by thermography | Detection by dye-penetrant inspection |
|----------------|--------------|---|---------------------------|---------------------------------------|
| 0 mm | 3 mm | Yes | Yes | Yes |
| 0 mm | 5 mm | Yes | Yes | Yes |
| 0 mm | 20 mm | Yes | Yes | Yes |
| 0.1 mm | 3 mm | Yes | Yes | No |
| 0.1 mm | 5 mm | Yes | Yes | No |
| 0.1 mm | 20 mm | Yes | Yes | No |
| 0.2 mm | 3 mm | Yes | Yes | No |
| 0.2 mm | 5 mm | Yes | Yes | No |
| 0.2 mm | 20 mm | Yes | Yes | No |
| 0.3 mm | 3 mm | Yes | Yes | No |
| 0.3 mm | 5 mm | Yes | Yes | No |
| 0.3 mm | 20 mm | Yes | Yes | No |

| | | | | |
|--------|-------|-----|-----|----|
| 0.4 mm | 3 mm | Yes | Yes | No |
| 0.4 mm | 5 mm | Yes | Yes | No |
| 0.4 mm | 20 mm | Yes | Yes | No |
| 0.5 mm | 3 mm | Yes | Yes | No |
| 0.5 mm | 5 mm | Yes | Yes | No |
| 0.5 mm | 20 mm | Yes | Yes | No |
| 0.6 mm | 3 mm | Yes | Yes | No |
| 0.6 mm | 5 mm | Yes | Yes | No |
| 0.6 mm | 20 mm | Yes | Yes | No |
| 0.8 mm | 3 mm | Yes | No | No |
| 0.8 mm | 5 mm | Yes | Yes | No |
| 0.8 mm | 20 mm | Yes | Yes | No |
| 1 mm | 3 mm | Yes | No | No |
| 1 mm | 5 mm | Yes | Yes | No |
| 1 mm | 20 mm | Yes | Yes | No |

Table 5: Comparison of performance of the inspection methods

The TOFD ultrasounds method was the subject of a technical demonstration file in reference [23]. The aim is to characterise the flaws described in the CPA method performance programme. This involves demonstrating the ability of the TOFD ultrasounds method to size the flaws detected with the CPA method.

Areva NP analysed the impact of the various influential parameters (presence of oxides, flaw geometry, flaw angle, implementation parameters) on the one hand using mock-ups with surface-breaking electro-eroded notches, or with variable ligaments and, on the other, by simulating treatments and using engineer assessments.

Areva NP concludes that when the CPA method has detected indications, the TOFD ultrasounds can size them when they are 1.5 mm x 3 mm or larger.

To verify that discontinuities that cannot be detected by dye-penetrant inspection, because they are filled with oxides, are detectable with magnetic particle and thermographic inspection, ASN asked Areva NP to inspect mock-ups oxidised by heat treatment using three methods (dye-penetrant, magnetic particle and CPA). The programme proposed by Areva NP consisted in producing four mock-ups, one for each inspection method (dye-penetrant, magnetic particle, CPA and ultrasounds). A surface-breaking flaw is located in each mock-up (length 5 mm, height 2.5 mm). These mock-ups are then oxidised. After several oxidation tests, using an oven oxidation technique combined with hot isostatic compression¹⁰, Areva NP was able to produce mock-ups which demonstrated that flaws filled with oxides and not detected by dye-penetrant inspection were detected by magnetic particle inspection and the CPA method. The results are presented in Table 6.

¹⁰ The hot isostatic compression technique consists in subjecting the parts to simultaneous high pressure and high temperature, in an inert atmosphere, in order to increase their compactness (elimination of internal porosities which could give rise to indications detected by dye-penetrant inspection).

| Technique | Number of flaws detected |
|--------------------------------------|--------------------------|
| Dye-penetrant | 0/4 |
| Long-duration dye-penetrant | 1/4 |
| Field magnetic particle inspection | 4/4 |
| Current magnetic particle inspection | 4/4 |
| Thermography | 4/4 |

Table 6: Results obtained on four surface-breaking flaws 5 mm long and 2.5 mm high, filled with oxides

The Flamanville EPR reactor pressure vessel bottom head was inspected with the CPA method by Areva NP from 16 August to 27 September 2016. Following this inspection, Areva NP noted six indications with a thermal signature requiring characterisation.

Areva NP characterised these indications by means of a visual inspection, given the fact that these indications were surface-breaking and not filled with oxide. The visual inspection report concludes that the six indications are in conformity with the “A”¹¹ criterion of the procedure in reference [24].

3.3. Position of the rapporteur

The inspections performed by Areva NP on the domes of the Flamanville EPR reactor pressure vessel prior to its commissioning are presented in Table 7 and Table 8.

¹¹ Non-compliant with criterion “A” are impacts, scratches, tool marks and scrapes deeper than 0.5 mm.

| Component | Inspected area | Type of inspection | Results | Inspection context and reference requirements |
|----------------|---|---|--|--|
| FA3 lower dome | Outer and inner faces after final machining | Dye-penetrant | Conforming No linear indication greater than 1 mm | Inspections performed during manufacturing in accordance with the RCC-M code and internally (see § 3.1 and [5]). |
| | Volume | 0° longitudinal wave ultrasounds from the inner face | November 2007 - Conforming A few point indications below the improved notation threshold, equivalent to the flat bottom hole of diameter 2 mm | |
| | Volume | 45° shear wave ultrasounds from the inner face | November 2007 - Conforming No indication | |
| | Outer face | Long-duration dye-penetrant | 23 March 2017 - Conforming No linear indication greater than 1 mm | Inspections performed in accordance with the Areva undertakings following the GP ESPN of 30 September, as per the criteria of the RCC-M code (see § 3.2.1 and [26]). |
| | Outer face | Dye-penetrant after spectrometry | 5 February 2015 - Conforming No linear indication greater than 1 mm | |
| | Volume | Ultrasounds DSR search inspection (entire surface) (see § 3.2.2.1) | 13 to 15 December 2016 Conforming | Inspections performed at request of ASN as per specific criteria [10] |
| | Outer face | Active photothermal camera (see § 3.2.2.2) | 16 to 27 August 2016 Six indications conforming after visual characterisation | |
| | Volume | 0° longitudinal wave ultrasounds from the outer face over a diameter of 1600 mm | 13 June 2017 - Conforming No notable indication | Inspections performed at request of rapporteur during review (see § 7.3) |
| | Volume | 45° shear wave ultrasounds from the outer face over a diameter of 1600 mm | 14 June 2017 - Conforming No notable indication | |

Table 7: Summary of inspections performed by Areva NP on the Flamanville EPR reactor pressure vessel lower dome

| Component | Inspected area | Type of inspection | Results | Inspection context and reference requirements |
|----------------|---|--|--|--|
| FA3 upper dome | Outer and inner faces after final machining | Dye-penetrant | Conforming No linear indication greater than 1 mm | Inspections performed during manufacturing in accordance with the RCC-M code and internally (see § 3.1 and [5]). |
| | Volume | 0° longitudinal wave ultrasounds from the inner face | October 2007 - Conforming No indication | |
| | Volume | 45° shear wave ultrasounds from the inner face | October 2007 - Conforming No indication | |
| | Outer face | Magnetic particle in peripheral zone | 22 to 24 January 2016 – Conforming No linear indication greater than 1 mm | Inspections performed in accordance with the Areva undertakings following the GP ESPN of 30 September, as per the criteria of the RCC-M code (see § 3.2.1 and [26]). |
| | Volume | Ultrasounds DSR search inspection after stress-relieving heat treatment (partial inspection as per Figure 7) | 3 to 8 February 2014 Conforming | Inspections performed according to ASN requests as per specific criteria (see § 3.2.2 and [10]). |
| | Volume | Ultrasounds DSR search inspection after stress-relieving heat treatment and after elimination of ridges (partial inspection as per Figure 7) | 25 to 26 June 2015 Conforming | |

Table 8: Summary of inspections performed by Areva NP on the Flamanville EPR reactor pressure vessel upper dome

3.3.1. Inspections performed during manufacturing

The rapporteur confirms its conclusions of 2015 recalled in section 3.1: the performance and results of the inspections performed during manufacturing enable one to conclude, with a reasonable degree of certainty, that there are no unacceptable flaws (see table 1) in the two domes of the Flamanville EPR reactor pressure vessel.

It however recalls that the non-destructive test inspections performed in the factory during manufacturing are not subject to a qualification requirement in the same way as the processes used for in-service inspection, as per the order of 10 November 1999 in reference [2].

3.3.2. Additional inspections of the outer surface of the domes

In response to the rapporteur's questions, Areva NP performed outer surface inspections on the Flamanville EPR reactor pressure vessel domes to ensure that no surface-breaking or subsurface flaw was present.

The rapporteur considers that the presence of surface-breaking flaws filled with oxides on the outer surface of the domes remains improbable for the upper and lower domes. Even though stress-relieving heat treatment operations were carried out after the dye-penetrant inspections performed at procurement of the domes, their surfaces were machined with no areas of roughness liable to trap oxides.

The rapporteur also considers that the inspections performed on the outer surface of the Flamanville EPR reactor pressure vessel lower dome are able to detect these surface-breaking flaws. The results obtained demonstrate the absence of harmful flaws. ASN also delegated a third-party organisation to monitor these additional inspections. In its reports sent to ASN, the third-party organisation found no nonconformity in the application of the Areva NP procedures.

It should be noted that, for the Flamanville EPR reactor pressure vessel upper dome, in its letter in reference [7], ASN shared the findings of the manufacturer *“whereby no inspection in addition to those already performed, related to the approach to demonstrate the presence of a positive macrosegregation, could be envisaged on the pressure vessel closure head”*. Even though the risk of the presence of surface-breaking flaws is low on the Flamanville EPR reactor pressure vessel closure head, the rapporteur considers that the lack of additional inspection of the outer surface of this dome meant that the absence of surface-breaking flaws could not be confirmed, more particularly if they are filled with oxides. The absence of this type of flaw in the upper dome of the Flamanville EPR reactor pressure vessel cannot therefore be guaranteed with as much certainty as for the lower dome.

3.3.3. Additional inspections to search for under-cladding flaws on the domes

The rapporteur considers that the inspections performed to detect under-cladding flaws on the Flamanville EPR reactor pressure vessel domes are appropriate for the detection of flaws potentially initiated by the welding operations on the austenitic stainless steel cladding. ASN delegated a third-party organisation to monitor these inspections. In its reports sent to ASN, the third-party organisation found no nonconformity in the application of the Areva NP procedures. The rapporteur considers that the presence of flaws with dimensions not conforming to the criteria of the technical specifications can be ruled out.

The rapporteur notes that in the case of the Flamanville EPR reactor pressure vessel closure head, the inspection could not be performed on the entirety of the wall concerned (92% covered). However, the entire potentially segregated zone was inspected.

4. Characterisation of the material

4.1. Test programme

The test programme, described in the document in reference [13], aims to evaluate the mechanical properties of the material necessary for analysing the mechanical strength of the Flamanville EPR reactor pressure vessel domes.

It consisted primarily in determining the toughness properties in the positive macrosegregation zone, so that they can be compared with the properties in the acceptance zone¹², taking account of this in the fast fracture risk assessment. The positive macrosegregation first had to be located and its scope and depth determined.

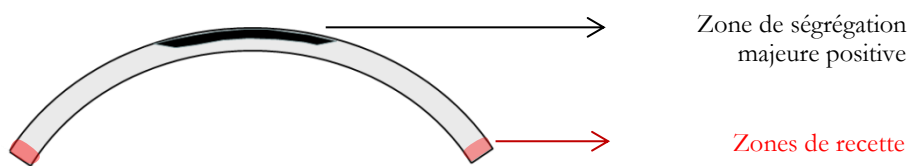

Figure 8: Cross-section of a dome - identification of acceptance and segregation zones
Positive macrosegregation zone
Acceptance zones

Given that the destructive tests cannot be performed on the domes of the Flamanville EPR reactor pressure vessel, because they would then render them unusable, the destructive tests in the programme were performed on samples taken from three scale-one replica domes, the UA and UK upper domes and the UA lower dome.

4.1.1. Programme performed by Areva NP

4.1.1.1. Content of the test programme

The Areva NP programme presented at the GP ESPN session of 30 September 2015 comprised tests on the UK upper dome and the UA lower dome, with specimens sampled at one-quarter thickness and mid-thickness, in the positive macrosegregation zone and at one-quarter thickness in the acceptance zone. The quarter-thickness is understood to be starting from the outer surface of the domes, corresponding to the top of the ingot.

Moreover, the core sample of material sampled from the centre of the UA upper dome, at the origin of the discovery of the anomaly in 2014 and the demonstration file proposed by Areva NP, was the subject of additional investigations in early 2016. The material of this core sample was characterised over its entire height by means of carbon content measurements through sampling of metal chips and by impact tests.

Following the initial carbon measurements in the thickness of the first two scale-one replica domes, as well as the bending rupture energy measurements at mid-thickness of the central core sample from the UA upper dome, Areva NP incorporated the UA upper dome into the test

¹² Zone defined by the manufacturing coordinates system in which the mechanical properties are tested.

programme during the course of 2016. The mechanical tests were also extended to three-quarters of the thickness of the UA lower and upper domes¹³.

The three scale-one replica domes underwent the following tests for each depth of interest in the positive macrosegregation zone:

- impact tests to establish a transition curve and determine the T_{CV} ¹⁴ and T_{68J} ¹⁴ transition temperatures;
- drop-weight tests to establish a T_{NDT} ¹⁴ transition temperature;
- additional impact tests in addition to the drop-weight tests to establish a RT_{NDT} ¹⁴ transition temperature;
- fracture toughness tests in the brittle-ductile transition domain (CT12,5 specimens) to characterise toughness versus temperature;
- tensile tests, associated with fracture toughness tests at the temperatures of the transition domain;
- fracture toughness tests in the ductile domain (CT25 specimens tested at 50°C, at the temperature of the periodic requalification tests and at 330°C, a temperature close to the reactor pressure vessel operating temperature), in order to evaluate the ductile tearing resistance;
- tensile tests, associated with the ductile tearing tests, also performed at 50°C and 330°C;
- tensile tests at ambient temperature, to compare the fracture elongation values with the 20% value mentioned in point 4 of appendix I of the ESPN order in reference [3].

Tests in the acceptance zone of the three scale-one replica domes and the two domes intended for the Flamanville EPR reactor pressure vessel were carried out:

- impact tests to establish a transition curve;
- fracture toughness tests and associated tensile tests, necessary for interpretation of the fracture toughness tests.

These tests supplement the initial acceptance tests (tensile, impact and drop-weight tests at one-quarter thickness from the inner surface) performed at manufacture of these domes, between 2006 and 2013.

Table 9 summarises the nature and number of tests in the test programme performed in 2016 per area of interest in the domes and identifies the laboratories in which the mechanical tests and chemical analyses were performed.

¹³ The UK upper dome was not selected owing to a carbon content at three-quarters thickness lower than those of the UA domes.

¹⁴ See definition of acronyms on p.13.

| Calotte | Température | FA3 inf | FA3 sup | UK sup | | | UA inf | | | | UA sup | | | | Total par type d'essai |
|--|------------------------------|-----------------|-----------------|-----------------|----------------------|----------------------|-----------------|----------------------|----------------------|----------------------|-----------------|----------------------|----------------------|----------------------|------------------------|
| Essais | | Zone de recette | Zone de recette | Zone de recette | Zone ségrégée 1/4 ép | Zone ségrégée 1/2 ép | Zone de recette | Zone ségrégée 1/4 ép | Zone ségrégée 1/2 ép | Zone ségrégée 3/4 ép | Zone de recette | Zone ségrégée 1/4 ép | Zone ségrégée 1/2 ép | Zone ségrégée 3/4 ép | |
| Résilience (courbe de transition) | variable (dont 0°C) | 18 | 18 | 18 | 72 | 52 | 18 | 36 | 36 | 36 | 18 | 36 | 36 | 36 | 430 |
| Résilience (pour RT _{NDR}) | fonction de T _{NDR} | / | / | / | 2x12 | 2x12 | / | 12 | 12 | 12 | / | 2x12 | 2x12 | 12 | 144 |
| Ténacité (ductile CT 25) | 50 et 330°C | 6 | 6 | 6 | 12 | 8 | 6 | 9 | 9 | 9 | 6 | 10 | 10 | 10 | 107 |
| Ténacité (fragile CT 12,5) | Variable | 40 | 40 | 48 | 144 | 84 | 38 | 72 | 72 | 48 | 20 | 74 | 72 | 48 | 800 |
| Traction | 50 et 330°C | 2 | 2 | 2 | 2 | 2 | 2 | 2 | 2 | 2 | 2 | 2 | 2 | 2 | 136 + 9 en peau |
| Traction | Ambiante | / | / | / | 3 | 3 | / | 3 | 3 | 3 | / | 3 | 3 | 3 | |
| Traction à T° de transition | Variable | 6 | 6 | 6 | 14 | 6 | 6 | 6 | 6 | 6 | 6 | 6 | 6 | 6 | |
| Pellni | Variable | / | / | / | 2x8 | 2x8 | / | 8 | 8 | 8 | / | 2x8 | 2x8 | 8 | 96 |
| Analyse chimique | | 18 | 18 | 74 | 286 | 193 | 19 | 143 | 147 | 122 | 17 | 167 | 169 | 121 | 1503 |
| Total par zone (hors analyses chimiques) | | 72 | 72 | 80 | 287 | 195 | 70 | 148 | 148 | 124 | 52 | 171 | 169 | 125 | 1722 |

| | |
|--|--|
| | Centre technique AREVA GmbH à Erlangen (Allemagne) |
| | SCK.CEN à Mol (Belgique) |
| | AMEC (Royaume-Uni) |
| | AREVA NP à Saint Marcel |
| | FILAB à Dijon |

Table 9: Summary of test programme per dome and laboratory

Calotte = dome

Essais = Tests

Zone de recette = Acceptance zone

Zone ségrégée = Segregation zone

xxx inf = xxx lwr

xxx sup = xxx upr

Total par type d'essai = Total per type of test

Impact (transition curve) variable (incl. 0°C)

Impact (for RT_{NDR}) fonction of T_{NDR}

Fracture toughness (ductile CT 25) 50 and 330°C

Fracture toughness (brittle CT 12,5) Variable

Tensile 50 and 330°C

Tensile Ambient

136 + 9 on surface

Tensile at transition temp. Variable

Drop-weight Variable

Chemical analysis

Total per zone (excl. chemical analyses)

AREVA GmbH Technical centre in Erlangen (Germany)

SCK CEN in Mol (Belgium)

AMEC (United Kingdom)

AREVA NP in Saint Marcel

FILAB in Dijon

4.1.1.2. Preparation and characterisation of the material

Before the test programme was performed by Areva NP, the following operations concerned the scale-one replica domes:

- the extent of the positive macrosegregation zone was determined from carbon content measurements taken on the outer surface by optical emission spectrometry;
- the domes were cut into half-domes along the segregated zone axis;
- the depth of the positive macrosegregation zone was determined by macrographic examination and measurement of the carbon content in the thickness of the scale-one replica domes by optical emission spectrometry;
- the segregation zones in the half-domes were cut into 400 mm x 400 mm blocks;
- the blocks were then cut into slices at the various depths of interest (quarter-thickness from the inner surface, mid-thickness and three-quarters thickness);

- the surface of the slices was characterised by measuring the carbon content using optical emission spectrometry, confirmed by measurements obtained in metal chips sampled at certain points, characterised by infrared combustion and confirmed by macrographic examination, in order to define the samples sampling plan in each slice.

Figure 9 represents the various steps involved in preparing the material of a scale-one replica dome for the tests to characterise its mechanical properties.

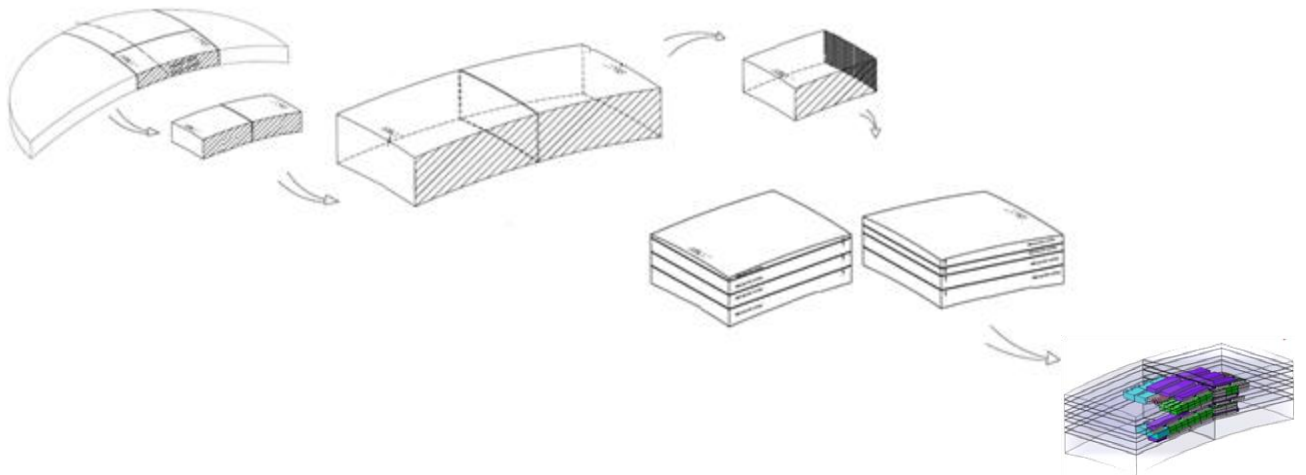

Figure 9: Steps in the preparation of a dome from the “half-dome” stage to the slices sampling plan

Figure 10 illustrates the position of the slices at the various depths of interest, with the nature of the tests associated with each slice.

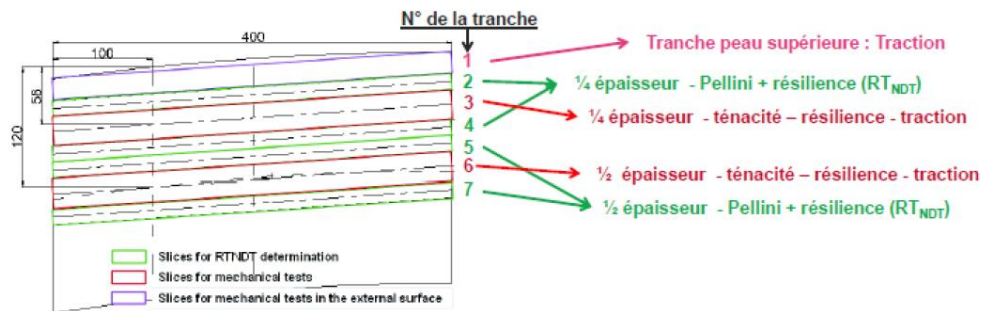

Figure 10: Cutting slices from blocks of segregated material (example: UK upper dome)

Slice N°

- Upper surface slice: Tensile
- 1/4 thickness – drop weight + impact (RTNDT)
- 1/4 thickness – fracture toughness – impact – tensile
- 1/2 thickness – fracture toughness – impact – tensile
- 1/2 thickness – drop weight + impact (RTND)

Figure 11 illustrates how the sampling plans are defined for the test samples using macrographic examinations and mapping of the carbon content on the slices at the various depths of interest, taking the example of one-quarter thickness of the UK upper dome. Appendix 9, Appendix 10 and Appendix 11 give all the carbon content maps produced during the test programme: on the surface of the five domes, at depth in the three scale-one replica domes and on the surface of the slices at the various depths of interest.

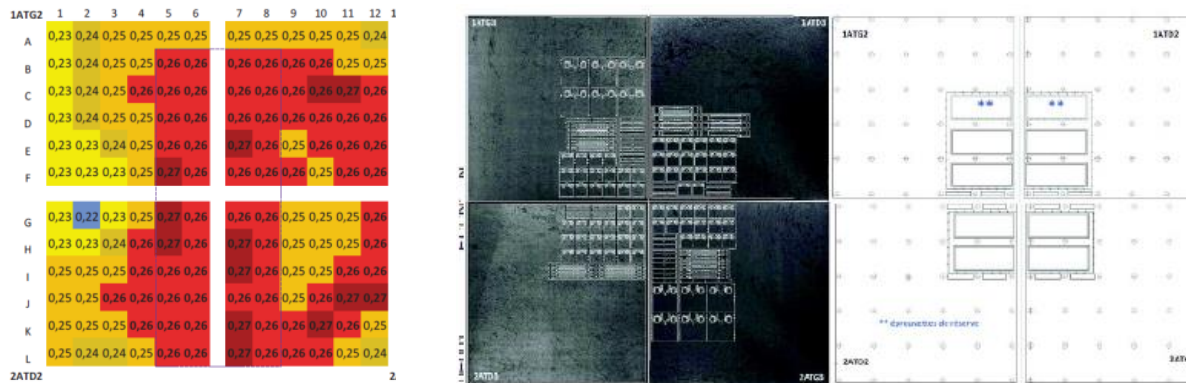

Figure 11: Sampling plan at one-quarter thickness of the UK upper dome
The values mentioned correspond to the carbon content (in %)

Finally, Figure 12 summarises the operations in the test programme performed by Areva NP, from characterisation of the positive macrosegregation zone up to storage of the material remaining after the programme, as well as its location and the industrial sites and laboratories which participated in the programme. Certain operations were subcontracted by the entities mentioned, such as cutting and machining, carbon content measurement by optical emission spectrometry and fractographic assessments.

Assessments (fractography-metallography)

Storage of remaining material (specimens and discards)
Chemical analyses on all specimens

Laboratoires d'expertise = assessment laboratories

4.1.1.3. Choice of test and assessment laboratories

Areva NP used three laboratories accredited in accordance with standard NF EN ISO/CEI 17025, two of which were independent of the Areva NP group, for performance of the mechanical properties characterisation tests:

- the Areva GmbH technical centre in Erlangen, Germany;
- the SCK.CEN in Mol, Belgium;
- the AMEC laboratory in the United Kingdom.

The drop-weight tests were performed by the Areva NP plant in Saint-Marcel in order to identify implementation conditions in identical industrial environments and according to the same edition of the ASTM E208 standard (1975 edition required by the RCC-M code and little used in the laboratory), for all the tests which provided results used in the file.

The metallographic and fractographic assessment were performed in the three laboratories in charge of the mechanical tests and seven other laboratories, four of which are independent of the Areva NP group:

- Areva NP in Saint-Marcel;
- Areva NP technical centre in Le Creusot;
- Areva NP technical centre in Saint-Marcel;
- CRMC Arcelor Mittal in Le Creusot;
- Bureau Veritas Laboratoires in Saint-Ouen l'Aumône;
- Bureau Veritas Laboratoires in Pessac;
- Filab in Dijon

4.1.1.4. Carbon content measurement methods

Areva NP utilised two carbon content measurement techniques to characterise the positive macrosegregation of the domes, for which the uncertainties were estimated using the method described in the document in reference [12]:

- optical emission spectrometry (OES)¹⁵ performed directly on the domes: Areva NP evaluates the uncertainty of this portable technique at $\pm 15\%$ for the instruments and the procedure of the outside contractor selected and at $\pm 10\%$ for the instrument and the procedure used by the Areva NP personnel;
- infrared combustion (IRC)¹⁶: for this technique requiring the sampling of material chips subsequently analysed by the independent Filab laboratory, the measurement uncertainty is evaluated at $\pm 5\%$.

In addition, the carbon content was measured on each specimen by infrared combustion on

¹⁵ This non-invasive technique is based on the sublimation of the material producing a light spectrum, the wavelengths of which are characteristic of the chemical element in question and the light intensity of which is linked to the concentration of the chemical element contained in the steel.

¹⁶ This locally invasive technique is based on the combustion of the material and measurement of the gases produced by infrared absorption.

metal chips by the external Filab laboratory.

The Filab laboratory is accredited in accordance with standard NF EN ISO/CEI 17025 for chemical analyses by infrared combustion, as well as for complete chemical analyses performed on a batch of specimens, using the ICP-AES¹⁷ technique, the reference technique, in order to verify the correlation between the content of the other alloy elements with that of carbon.

4.1.1.5. Thermal ageing

AREVA considers that the pressure vessel upper and lower domes are not subjected to irradiation ageing. The reactor pressure vessel bottom dome is separated from the lower core plate by more than a metre of water and the fast neutron flux is about 10^4 n/cm²/s (as compared with a flux of 10^{10} n/cm²/s at the core shells). The upper dome is separated from the top of the reactor core by more than 5 metres of water, which reduces the flux by an additional few decades. For such levels of flux and therefore of fluence, no irradiation damage is expected.

The potential ageing mechanisms for the steel in the domes are thus strain ageing and thermal ageing, which lead to a reduction in fracture toughness over time. This reduction can be expressed by a shift in the RT_{NDT} in relation to the initial RT_{NDT} .

The thermal ageing phenomenon is due to the diffusion of phosphorus at the grain boundaries, which weakens the grain boundaries and thus increases the brittle-ductile transition temperature. EDF summarised available knowledge on thermal ageing due to diffusion of embrittling elements at the grain boundaries, in reference [32].

On the basis of this summary, Areva NP and EDF consider that a flat rate shift in RT_{NDT} of +15°C covers the thermal ageing and strain ageing effect on the fracture toughness properties of the steel in the Flamanville EPR reactor pressure vessel domes for 60 years of operation.

Areva NP and EDF nonetheless proposed carrying out a programme to monitor the behaviour at temperature of samples taken from the positive macrosegregation zone, so that initial results equivalent to 60 years of operation are available on the occasion of the first ten-yearly outage inspection of the Flamanville EPR reactor.

This test programme, in reference [33], consists in using impact strength specimens taken from the segregated material of the UA upper and lower domes (on outer surface for upper dome and at mid-thickness for lower dome) to establish transition curves in the brittle-ductile transition domain.

Three specimens are tested at each of the six predetermined test temperatures, in a reference state (not aged) and in the aged state for the two domes tested.

The aged state is obtained by means of accelerated ageing heat treatment at a temperature of 375°C, higher than the operating temperature, which does not exceed 330°C. The ageing time equivalent to 60 years of operation is estimated by EDF at 39,000 hours, or less than 4.5 years.

The impact test specimens will be sampled from zones containing the maximum phosphorus level recorded in the test programme on the scale-one replica domes, or about 0.008%.

¹⁷ Inductively coupled plasma atomic emission spectroscopy.

4.1.2. Position of the rapporteur

4.1.2.1. *Content of the test programme*

Characterisation of the positive macrosegregation

The characterisation and the test programme were similar for the three scale-one replica domes, in accordance with Areva NP undertaking n° 5 in the letter in reference [26].

The rapporteur considers that the characterisation process used for the domes by Areva NP via carbon content measurements at different planes, using measurement methods with estimated measurement uncertainties, allowed an adequate and satisfactory definition of the spatial distribution (position and scope) of the positive macrosegregation and its maximum carbon content.

Adequacy of the programme with the material characterisation objective

The scope of the positive macrosegregation zone on the three scale-one replica domes enabled Areva NP to take the required number of samples, with no restriction. More specifically, despite the lesser thickness, drop-weight test specimens were able to be sampled from the UA lower dome.

No sample was taken at three-quarters thickness of the UK upper dome owing to the carbon content (less than 0.20%) that is lower than those of the UA domes at this depth (about 0.26%).

The rapporteur considers that Areva NP engaged a number of specimens in the test programme that was sufficient to:

- determine the transition curve and the T_{CV} and T_{68J} transition temperatures of each of the scale-one replica domes;
- determine the T_{NDT} transition temperature of each of the scale-one replica domes;
- determine the RT_{NDT} transition temperature of each of the scale-one replica domes;
- evaluate the ductile tearing strength of each of the scale-one replica domes;
- determine the transition temperature resulting from the fracture toughness tests on each of the scale-one replica domes.

The adequacy of the test programme is also analysed in the light of the interpretation of the test results in section 4.3.8.

Heat treatment

The test coupons for the three scale-one replica domes received simulated stress-relieving heat treatment equivalent to that actually undergone by the domes of the Flamanville EPR reactor pressure vessel, in accordance with Areva NP undertaking n° 6 in the letter in reference [26].

Positioning of specimens

During the dome preparation steps and until the definition of the sampling plans, specimens were associated with regular hold points lifted by ASN after analysis of the data transmitted by Areva NP, in accordance with requests n° 5 and 6 in the ASN letter in reference [7]. The rapporteur considers that the specimens were sampled from the core of the segregated material

and allow characterisation of its mechanical properties, as confirmed by the chemical analyses performed on each specimen tested.

4.1.2.2. Choice of test laboratories

The rapporteur notes that:

- in accordance with request n° 7 in the ASN letter in reference [7], Areva NP called on a laboratory independent from Areva NP and accredited in accordance with standard NF EN ISO/CEI 17025 to carry out the chemical analyses by infrared combustion as well as for the complete chemical analyses using the ICP-AES technique on metal chips;
- in accordance with request n° 8 of the ASN letter in reference [7], Areva NP used three laboratories accredited in accordance with standard NF EN ISO/CEI 17025, two of which are independent of the Areva NP group, for performance of the mechanical tests.

For the test programme, the Areva GmbH laboratory in Erlangen carried out:

- tests on the segregation zone of the UK upper dome;
- tests at one-quarter thickness of the UA upper dome;
- all the ductile tearing tests in the segregation zone of the three scale-one replica domes.

The rapporteur found no inconsistency in the results of the tests performed by the Areva GmbH laboratory, by comparison with the results obtained by the two laboratories independent of the Areva NP group.

The rapporteur did not question the choice by Areva NP to entrust all the ductile tearing tests to the same laboratory, given the fact that the SCK.CEN and AMEC laboratories were not able to perform the tests at 330°C.

ASN conducted an unannounced inspection of the Areva GmbH laboratory in Erlangen, Germany, to examine the technical and organisational conditions implemented for performance of the mechanical tests entrusted to this laboratory by Areva NP. No major point was observed in the performance of the tests and in the management of the laboratory (ASN inspection follow-up letter in reference [27]).

As for the drop-weight tests, the rapporteur does not question the choice by Areva NP to entrust them to the Areva NP plant in Saint-Marcel, in order to guarantee similar testing conditions for all the results presented in the file. ASN carried out an inspection on the preparation of the specimens and performance of the drop weight tests in the Areva NP plant in Saint-Marcel, and observed a deviation with no impact on the file (ASN inspection follow-ups letter in reference [28]).

Moreover, the steps in the process described in Figure 12 were monitored by a third-party organisation delegated by ASN. This point is detailed in section 4.1.3 of this report.

4.1.2.3. Evaluation of uncertainties in the carbon content measurement

The rapporteur considers that the uncertainty values associated with the carbon content measurements adopted by Areva NP in its file are acceptable.

The rapporteur states that these uncertainties are specific to the techniques, instruments and procedures evaluated by Areva NP. Consequently, these results cannot be applied to any other configuration not covered by the evaluations carried out by Areva NP.

4.1.2.4. *Thermal ageing*

The study of the effect of thermal ageing, using changes in the bending rupture energy properties is a well-established, state of the art practice. The rapporteur therefore considers that the transition temperature shift obtained from a test programme is a pertinent indicator for evaluating thermal ageing and thus the minimum bending rupture energy of the material.

For the thermal ageing studies, the transition temperature conventionally used is TK_{56J} (temperature corresponding to a shock bending energy of 56 joules). EDF therefore proposes utilising the results of the impact tests of the ageing programme, considering TK_{56J} . To enable these results to be compared with the impact tests performed during the test programme on the Flamanville EPR reactor pressure vessel domes, EDF agrees to provide the TK_{56J} values corresponding to the transition curves of the scale-one replica domes [79]. The rapporteur considers this undertaking to be satisfactory.

The rapporteur considers the number of specimens and the number of transition curves, at the ageing temperature chosen by EDF, to be adequate for establishing the shift in fracture toughness properties linked to thermal ageing. The number of specimens is notably equivalent to what is used to monitor the behaviour of pressure vessel steel in the irradiated zone. Moreover, the rapporteur had no particular comments on the choice of scale-one replica parts for taking samples, insofar as it is primarily determined by the phosphorus content, recognised as being the main contributor to the phenomenon of thermal ageing.

The rapporteur considers that the accelerated ageing test temperature of 375°C chosen by EDF, enables the first results to be obtained before the first ten-yearly outage inspection of the Flamanville EPR reactor, without moving too far from the actual operating temperature. However, thermal ageing of a heavily segregated pressure vessel material has never yet been studied. An extension of the programme to a temperature closer to the operating temperature would be able to confirm that the metallurgical phenomena taking place during accelerated ageing are indeed representative of the phenomena postulated at the operating temperatures.

The rapporteur considers that the thermal ageing programme must be supplemented with a batch of impact test specimens thermally aged at a temperature as close as possible to the reactor operating conditions and in any case below 350°C, with all the other test conditions (scale-one replica domes concerned and protocol for determining the transition curves) being equivalent to the programme proposed at 375°C.

To supplement the proposed programme at an ageing temperature of 375°C for about 4.5 years, EDF agreed – at the request of the rapporteur – to take 18 additional samples from the outer surface of the scale-one replica UA upper dome, to produce a brittle-ductile domain transition curve from the impact tests. These specimens will undergo ageing heat treatment at a temperature of 350°C for about 17 years [79]. The aged material bending rupture energy transition curve will be established over the same time-frame [79]. The rapporteur considers this undertaking to be satisfactory.

4.1.3. Monitoring of the test programme by a third-party organisation delegated by ASN

4.1.3.1. *Monitoring objectives and methods*

The Bureau Veritas Exploitation¹⁸ organisation was delegated by ASN to evaluate compliance with the methods and conditions for performance of the test programme by Areva NP on the various domes, as well as for the carbon content measurements on the Flamanville EPR reactor pressure vessel domes. Bureau Veritas Exploitation is qualified by ASN to perform this type of monitoring. This qualification was issued following an audit and compliance with the qualification conditions is regularly inspected by ASN.

The scope of the mandates given to Bureau Veritas Exploitation comprised documentary reviews and monitoring in the field.

The documentary reviews concerned:

- analysis of the impact of changes to the test standards utilised by Areva NP;
- verification of the scope of accreditation of the laboratories;
- verification of the consistency of the technical documents produced by Areva NP with the basic documents transmitted to ASN (specimens sampling plans in particular);
- traceability of the results in the documentation (consistency of laboratory reports with the operations performed and consistency of the test results entered in the Areva NP files).

Monitoring in the field, presented in detail in section 4.1.3.2, was carried out on all the sites on which the test programme material was present (shown in Figure 12), in accordance with the sampling rules validated by ASN.

This monitoring in the field concerned:

- metrological verification of the measuring instruments used in the programme;
- verification of the qualification of the operators involved in performing the tests;
- verification of compliance with the standards invoked by the documentation applicable to the programme;
- verification of compliance with the conditions and methods for implementation of the programme, in accordance with the documentation applicable to the programme (sequence of operations, material conservation during the programme and final storage);
- verification of the traceability and conservation of the materials (discards and specimens).

Furthermore, whenever deviations were identified, Bureau Veritas Exploitation issued a decision on:

- the processing of the detected deviations by Areva NP and its subcontractors;
- the answers provided by Areva NP when processing the deviations detected by Bureau Veritas Exploitation.

¹⁸ The Bureau Veritas Exploitation entity monitoring the test programme is not the same as Bureau Veritas Laboratoires entity mentioned in section 4.1.1.3.

The rapporteur examined the results of this monitoring through the reports issued by Bureau Veritas Exploitation on the monitoring of the operations performed by Areva NP on the central core sample from the UA upper dome in reference [30], and on the scale-one replica domes in reference [31].

4.1.3.2. Quantitative monitoring report

The monitoring ratios per dome and per operation are shown in Table 10. The vast majority of the operations were 100% monitored.

For the chemical analyses carried out in an independent laboratory on the material in the segregation zone, the monitoring ratio was modified at the end of the programme, on the basis of a substantiated proposal from Bureau Veritas Exploitation and with the consent of ASN. For its part, the appraisal of the specimens was monitored on the basis of spot-checks, with the consent of ASN.

| | Acceptance zone | | | | | Segregation zone | | |
|--|--|-----------|----------|----------|-----------|---|----------|----------|
| | FA3 upper | FA3 lower | UK upper | UA upper | UA lower | UK upper | UA upper | UA lower |
| Characterisation of the segregation zone | - | - | - | - | - | 100 % | 100 % | 100 % |
| Identification / Traceability of coupons | 100 % | 100 % | 100 % | 100 % | 100 % | 100 % | 100 % | 100 % |
| Stress-relieving heat treatment of coupons | 100 % | 100 % | 100 % | 100 % | 100 % | 100 % | 100 % | 100 % |
| Traceability / cutting of specimens | At each marking and punching | | | | | 100 % | 100 % | 100 % |
| Tensile tests | 100 % | 100 % | 100 % | 100 % | 100 % | 100 % | 100 % | 100 % |
| Impact tests | 100 % | 100 % | 100 % | 100 % | 100 % (*) | 100 % | 100 % | 100 % |
| Fracture toughness tests in the brittle-ductile domain (CT 12,5) | 100 % | 100 % | 100 % | 100 % | 100 % | 100% of tests + minimum of one pre-cracking per day | | |
| Fracture toughness tests in the ductile domain (CT25) | 100 % | 100 % | 100 % | 100 % | 100 % | | | |
| Dimensional check on specimens | Monitoring of important dimensions – Report verification | | | | | | | |
| Drop-weight tests | Not concerned because performed during manufacturing | | | | | 100 % | 100 % | 100 % |
| Sampling of metal chips | 100 % | 100 % | 100 % | 100 % | 100 % | 100 % | 100 % | 100 % |
| Chemical analyses | 100 % | 100 % | 100 % | 100 % | 100 % | 100% then unannounced weekly inspection | | |

(*) with the exception of 3 specimens

Table 10: Test programme monitoring ratios

The quantitative summary of monitoring carried out by Bureau Veritas Exploitation, per type, is given in Table 11. The differences between domes are due to the differences between the quantities of specimens engaged in the test programme.

| Dome concerned by monitoring | Preparation and reporting (m.d) | Management (m.d) | Field inspection (m.d) | Total per dome (m.d) |
|------------------------------|---------------------------------|------------------|------------------------|----------------------|
| UA upper | 250 | 304 | 291 | 845 |
| UA lower | 151 | 307 | 233 | 691 |
| UK upper | 126 | 248 | 185 | 559 |
| FA3 lower | 20 | 30 | 23 | 73 |
| FA3 upper | 26 | 44 | 40 | 110 |

Table 11: Estimated figures for monitoring by Bureau Veritas Exploitation (in man.days)

4.1.3.3. Processing of deviations

The quantitative summary of deviations opened by Areva NP and its subcontractors, and the observation and nonconformity sheets opened by Bureau Veritas Exploitation, are shown in Table 12.

| Site | Deviations detected by manufacturer/subcontractor submitted to the third-party organisation | Observation sheets opened by Bureau Veritas Exploitation | Non-conformity sheets opened by Bureau Veritas Exploitation |
|--|---|--|---|
| Areva Creusot Forge | 1 | 1 | 0 |
| Areva St Marcel | 10 | 12 | 1 |
| Areva NP laboratory in Erlangen (Germany) and its subcontractors | 15 | 5 | 0 |
| SCK laboratory in Mol (Belgium) and its subcontractors | 13 | 4 | 2 |
| AMEC GB laboratory and its subcontractors | 23 | 3 | 0 |
| Filab laboratory in Dijon | 0 | 1 | 0 |
| Areva NP technical centre laboratory in Le Creusot | 0 | 2 | 0 |
| Bureau Veritas Laboratoires (Pessac and Saint-Ouen-L'Aumône); | 0 | 1 | 0 |
| Flamanville | 0 | 1 | 0 |

Table 12: Summary of deviations processed by Bureau Veritas Exploitation

All the deviations opened by Areva NP and subcontractors were examined by Bureau Veritas Exploitation and the rapporteur who considered that the processing of each one is appropriate.

All of the observation and non-conformity sheets have been closed.

4.1.3.4. Opinion of Bureau Veritas Exploitation

Bureau Veritas Exploitation issued a satisfactory opinion on all the monitoring points, although it did express reservations which were processed and felt to have no impact on the dossier by the rapporteur.

4.1.4. Position of rapporteur regarding implementation of the test programme

Bureau Veritas Exploitation carried out its mission to monitor the test programme run by Areva NP in accordance with the requirements of the mandates given it by ASN. The rapporteur thus considers that the confidence acquired in monitoring of the test programme by Bureau Veritas Exploitation reflects on the results presented by Areva NP.

The rapporteur considers that the monitoring performed by Bureau Veritas Exploitation and the inspections carried out by ASN provide technical and impartiality guarantees with regard to compliance with the applicable documentation, traceability, the performance of the tests in accordance with the state of the art and the accuracy of the results of the test programme carried out by Areva NP on the five reactor pressure vessel domes.

4.2. Representativeness of the scale-one replica domes with respect to those of the Flamanville EPR reactor pressure vessel.

4.2.1. Principles of the Areva NP approach to analysis of the representativeness of the scale-one replica domes

The approach to analyse the representativeness of the scale-one replica domes with respect to those of the Flamanville EPR reactor pressure vessel is presented by Areva NP in the documents in reference [11] and [12]. The aim of this approach is to identify the parameters which influence the fast fracture resistance of such components and to study the variations between scale-one replica domes and those of the Flamanville EPR reactor pressure vessel.

Among the factors which influence the fast fracture resistance of such components, Areva NP highlights two principal factors in the brittle and the brittle-ductile transition domains:

- the carbon content. The fracture toughness properties drop as this content rises;
- the quenching effect, characterised by the rate of cooling between 800°C and 600°C at immersion in the water of the quenching bath after austenitisation. The higher the quenching rate, the better the quenching effect and the fracture toughness properties for this type of steel.

Although without using them, Areva NP identified other factors affecting the fast fracture resistance:

- the additives other than carbon, influencing quenchability. As the content of these elements changes correspondingly with the carbon content within a positive macrosegregation zone, Areva NP focused solely on the carbon content;
- the austenitic grain size, which also influences quenchability. Areva NP considers that the imposed austenitisation temperature and duration ranges are sufficient to prevent significant variation between domes;
- segregation of phosphorus at the grain boundaries, influencing in-service thermal ageing. Areva NP considers that the phosphorus content at pouring reaches very low values for all the domes, to the extent that the impact of this element is secondary with regard to the fracture toughness and that the concentration variations are negligible.

The two principal factors having been defined, Areva NP studies the parameters with an influence on their amplitude, and compared them in order to evaluate the representativeness of the scale-one replica domes with respect to the domes of the Flamanville EPR reactor pressure vessel.

These parameters, described in the following sections, can be placed in three categories, according to the nature of the guarantees they provide:

- documentary elements, such as records of manufacturing parameters;
- elements evaluated by numerical simulation;
- experimental data, resulting from physical tests performed at the time of manufacturing or during the test programme on scale-one replica domes.

4.2.2. Parameters influencing the carbon content

4.2.2.1. *Documentary elements and numerical simulation evaluation*

With regard to the parameters that can influence the carbon content and, more broadly, the maximum segregation ratio and the positioning in the segregation zone, Areva NP studied the following manufacturing parameters for the three scale-one replica domes and the two domes of the Flamanville EPR reactor pressure vessel:

- the ingot pouring and solidification parameters;
- the forging and hot forming parameters and data;
- the machining parameters (removal of material).

Ingot pouring and solidification parameters

These parameters are:

- the mass of the ingot;
- the mass of the feeder and the feeding ratio¹⁹;
- the mass of the ladle;
- the pouring rate;
- the duration of application of exothermic powders;
- the ingots cooling time;
- the depth of shrinkage²⁰;
- the contents at pouring of the various chemical elements (carbon, manganese, silicon, molybdenum, sulphur, phosphorus, vanadium, nickel, chromium).

| | FA3 upper | | UA upper | | UK upper | |
|----------------|-------------|----------|-------------|----------|-------------|----------|
| | Required | Obtained | Required | Obtained | Required | Obtained |
| C | 0.20 % max | 0.18 % | 0.20 % max | 0.18 % | 0.20 % max | 0.19 % |
| Mn | 1.15-1.55 % | 1.55 % | 1.20-1.50 % | 1.46 % | 1.15-1.55 % | 1.57 % |
| P | 0.008 % max | 0.003 % | 0.008 % max | 0.004 % | 0.008 % max | 0.005 % |
| S | 0.005 % max | 0.001 % | 0.005 % max | 0.001 % | 0.005 % max | 0.001 % |
| Si | 0.10-0.30 % | 0.17 % | 0.15-0.30 % | 0.18 % | 0.10-0.30 % | 0.20 % |
| Ni | 0.50-0.80 % | 0.72 % | 0.50-0.80 % | 0.71 % | 0.50-0.80 % | 0.71 % |
| Cr | 0.25 % max | 0.17 % | 0.25 % max | 0.18 % | 0.25 % max | 0.16 % |
| Mo | 0.45-0.55 % | 0.51 % | 0.45-0.55 % | 0.49 % | 0.45-0.55 % | 0.52 % |
| V | 0.01 % max | 0.001 % | 0.01 % max | 0.005 % | 0.01 % max | 0.001 % |
| Cu | 0.10 % max | 0.04 % | 0.10 % max | 0.04 % | 0.10 % max | 0.06 % |
| Al | 0.04 % max | 0.02 % | 0.04 % max | 0.01 % | 0.04 % max | 0.01 % |
| Co | 0.03 % max | 0.01 % | 0.03 % max | 0.01 % | 0.03 % max | 0.01 % |
| H ₂ | 1.5 ppm max | 0.95 ppm | 1.5 ppm max | 0.94 ppm | 1.5 ppm max | 1.10 ppm |

Table 13: Comparison of chemical compositions at pouring of the FA3, UA and UK upper domes

¹⁹ Proportion of the mass of the feeder to the total mass of the ingot.

²⁰ Cavity formed at the top of the ingot, due to the contraction of the metal at solidification.

| | FA3 lower | | UA lower | |
|----------------|-------------|-------------------------|-------------|-------------------------|
| | Required | Obtained | Required | Obtained |
| C | 0.20 % max | 0.18 % | 0.20 % max | 0.18 % |
| Mn | 1.15-1.55 % | 1.55 % | 1.20-1.50 % | 1.58 % |
| P | 0.008 % max | 0.004 % | 0.008 % max | 0.005 % |
| S | 0.005 % max | 0.001 % | 0.005 % max | 0.001 % |
| Si | 0.10-0.30 % | 0.18 % | 0.15-0.30 % | 0.18 % |
| Ni | 0.50-0.80 % | 0.75 % | 0.50-0.80 % | 0.71 % |
| Cr | 0.25 % max | 0.14 % | 0.25 % max | 0.16 % |
| Mo | 0.45-0.55 % | 0.51 % | 0.45-0.55 % | 0.51 % |
| V | 0.01 % max | 0.001 % | 0.01 % max | 0.001 % |
| Cu | 0.10 % max | 0.04 % | 0.10 % max | 0.06 % |
| Al | 0.04 % max | 0.02 % | 0.04 % max | 0.01 % |
| Co | 0.03 % max | 0.01 % | 0.03 % max | 0.009 % |
| H ₂ | 1.5 ppm max | 0.95 ppm (see § 7.2) | 1.5 ppm max | 1.07 ppm (see § 7.2) |

Table 14: Comparison of chemical compositions at pouring of the FA3 and UA lower domes

| | Upper domes | | | Lower domes | |
|--------------------|--------------|--------------|--------------|--------------|--------------|
| | FA3 | UA | UK | FA3 | UA |
| Type of ingot | Conventional | Conventional | Conventional | Conventional | Conventional |
| Type of ingot cast | 2550 | 2550 | 2550 | 2550 | 2550 |
| Weight of ingot | 156.9 t | 157.1 t | 158.6 t | 157.4 t | 158.5 t |

Table 15: Essential parameters in pouring and solidification of FA3, UA and UK upper domes and FA3 and UA lower domes

Comparing the pouring and solidification parameters for the various ingots enables Areva NP to conclude that there is no deviation liable to lead to significant differences in the maximum rate of segregation and distribution of the segregation zone in the volume of the poured ingots.

The forging and hot forming parameters and data

These parameters are:

- the forging procedure;
- the cumulative duration of those periods in which the part is hot;
- the thickness in the axis of the gross forging blank;
- the lengths and weight of top and bottom discards;
- the forging ratio²¹ ;
- the hot forming.

The comparison of the forging and hot forming conditions shows that the contour shaping²² phase led for the Flamanville EPR reactor pressure vessel upper dome to a lesser thickness on the gross blank axis, owing to greater depression of the forging tool.

By means of forging simulations, Areva NP shows that the consequences of this operation are slight both on the depth of segregation (the carbon content chosen as the indicator is reached at 50% of the thickness of the blank in the reference case, as against 56% in the case of the upper

²¹ Ratio between the lengths of a metal element after and before the forging operation (e.g. initial height / final height in the event of an upsetting operation).

²² Contour shaping is an operation to upset the centre of the part using a forging tool called a contour shaper.

dome of the Flamanville EPR reactor pressure vessel) and on the radial extension of segregation (the estimated diameter of the positive macrosegregation zone is 927 mm for the reference case, as opposed to 1036 mm in the case of the Flamanville EPR reactor pressure vessel upper dome).

Parameters concerning removal of material

These parameters are defined according to the thicknesses removed:

- by discard at top and bottom of the ingot (see Table 16);
- by fire losses;
- by machining of the blank before hot forming, before quality heat treatment and for achieving the final delivery profile.

| | Upper domes | | | Lower domes | |
|----------------|-------------|--------|--------|-------------|--------|
| | FA3 | UA | UK | FA3 | UA |
| Top discard | 20 % | 19,7 % | 18,2 % | 20 % | 19,7 % |
| Bottom discard | 9 % | 8.5 % | 10 % | 8 % | 8.5 % |

Table 16: Discard rates of FA3, UA and UK upper domes and FA3 and UA lower domes

Areva NP reveals that the removal of material by machining is a parameter influencing the position of the residual macrosegregations in the domes. By comparing the manufacturing parameters, Areva NP shows that there is a certain variability between the various domes in the thickness of material removed at the various manufacturing stages.

Areva NP consequently focused on identifying the various thicknesses of material removed from a reference bloom²³ which, in the end, makes it possible to visualise the theoretical location of the material of the finished parts in this bloom. Areva NP chose to estimate the altitude of the finished parts at the bloom stage, because this is the first stage in manufacturing offering a simple geometry and enabling the various parts to be compared.

Estimation of the altitude of the finished parts in a reference bloom

In the reference bloom, Areva NP marked out the region which, at this stage of production, contains the material which is to be found in each dome at the final stage of manufacturing (after forging and machining). This work aims to compare the altitude of the material of the various domes on the basis of this reference bloom. The useful height of the reference bloom was defined in accordance with the domes technical manufacturing programme and is identical for all the domes.

Estimation of the altitude of the finished parts in the bloom takes account of:

- the removal of material by discard and machining at various stages;
- the loss of material to fire;
- the consideration of uncertainties that Areva NP has evaluated from the manufacturing documentation.

²³ A bloom is an intermediate state of the part, between the ingot (after pouring) and the final forging, obtained after a forging operation aiming to obtain a constant diameter over its entire height.

Figure 13 represents the various thicknesses considered in order to determine the altitude and extent of the upper dome of the Flamanville EPR reactor pressure vessel in the reference bloom. Figure 14 allows a comparison between the relative positioning of the various domes in this same bloom. These figures only show the axial position (altitude) of the central part of the final part. Areva NP did not represent the part in its entirety because the positioning of the peripheral zone of a dome is more complicated to recreate owing to the forging operations undergone by this zone. Moreover, the lateral part is of lesser interest for the file, as the maximum segregation zone is in the centre of the dome.

The greater upsetting carried out in the centre of the upper dome of the Flamanville EPR reactor pressure vessel, therefore means that this dome is higher than the others. However, the machining carried out leads to a part position that is lower in the bloom.

Given the greater machining carried out, the lower domes are on the whole in a more favourable position when it comes to eliminating the positive macrosegregation at the top.

Consequently, Areva NP concludes that the positioning of the scale-one replica domes would appear to be more penalising in terms of the presence of residual carbon macrosegregations than the upper and lower domes for the Flamanville EPR reactor pressure vessel.

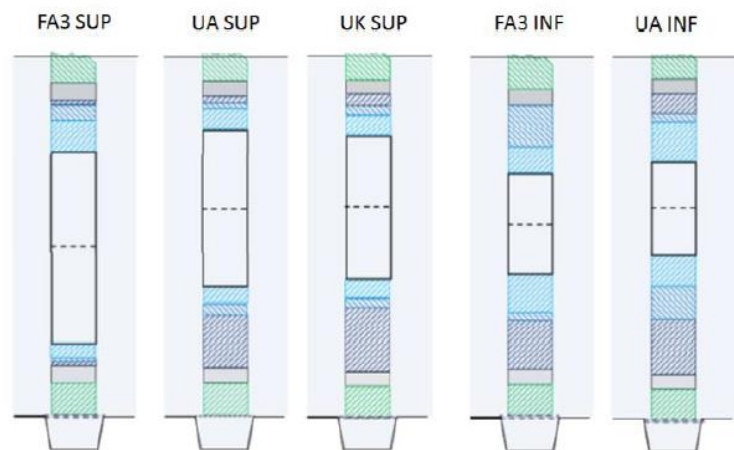
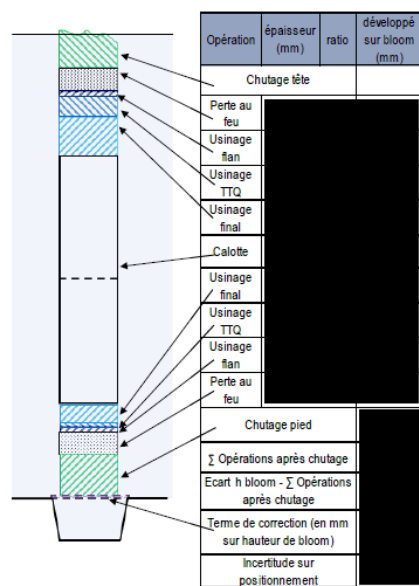

Useful height of reference bloom: 4660 mm
Positioning uncertainty: ± 250 mm

Figure 13: Example of recreation of positioning (FA3 upper)

Figure 14: Positioning of various domes in the reference bloom

| Operation | Thickness (mm) | ratio | developed on bloom (mm) |
|-----------------|----------------|-------|-------------------------|
| Top discard | | | |
| Fire loss | See table | | |
| Blank machining | | | |
| QHT machining | | | |
| Final machining | | | |
| Dome | | | |
| Final machining | | | |
| QHT machining | | | |
| Blank machining | | | |
| Fire loss | See table | | |
| Base discard | | | |

Operations after cropping
 Difference h bloom – Σ Operations after cropping
 Correction term (in mm on height of bloom)
 Positioning uncertainty

4.2.2.2. *Experimental data*

Comparison of carbon contents in acceptance zone

The various carbon contents measured in the acceptance zone (along with the values at pouring for information) are presented in Table 17. These values take account of all the specimens tested during the test programme.

Areva NP considers that the carbon rates in the acceptance zone of the two domes of the Flamanville EPR reactor pressure vessel do not stand out with respect to the three scale-one replica domes.

| Dome | Carbon contents | | | | |
|-----------|-----------------|-------------------------|-----------------------|-----------------------|-------------------------|
| | Pouring | Acceptance measurements | | | |
| | | Number of specimens | Max. acceptance value | Min. acceptance value | Median acceptance value |
| UK upper | 0.187 % | 78 | 0.179 % | 0.169 % | 0.175 % |
| UA lower | 0.179 % | 25 | 0.177 % | 0.172 % | 0.174 % |
| UA upper | 0.182 % | 17 | 0.191 % | 0.175 % | 0.183 % |
| FA3 upper | 0.182 % | 18 | 0.179 % | 0.175 % | 0.178 % |
| FA3 lower | 0.181 % | 26 | 0.194 % | 0.177 % | 0.185 % |

Table 17: Comparison of carbon contents at pouring and on specimens tested in acceptance zone

Comparison of carbon content surface maps

Areva NP compared the carbon content measurements taken on the surface of the scale-one replica domes and the domes of the Flamanville EPR reactor pressure vessel. These values were obtained through several measurement campaigns, involving different techniques and several measuring instruments.

The various carbon content surface maps of each dome are presented in Appendix 9.

As the analysis of the measurements requires a robust understanding of the uncertainties linked to the techniques used, Areva NP adopted:

- a methodology to evaluate the uncertainties in the measurement techniques (see section 4.1.1.4);
- post-processing of the carbon content maps on the outer surface, using a geostatistical approach.

The carbon contents measured on the inner face, during manufacturing and during the investigations carried out in 2016, are presented in Table 18.

| Dome | UK upper | UA lower | UA upper | FA3 upper | FA3 lower |
|---|----------|----------|----------|---|-----------|
| IRC (*) measurement (during manufacturing) | 0.19 % | 0.18 % | 0.19 % | 0.17 % | 0.16 % |
| Maximum measurement by OES in 2016 | 0.18 % | 0.21 % | 0.19 % | No measurement because of presence of cladding | |

(*) on metal chip sampled from acceptance ring

Table 18: Measurement of carbon content on inner surface

The maximum carbon contents measured on the outer surface (using the portable OES technique²⁴ on the Flamanville EPR reactor pressure vessel domes) and by OES and CIR²⁵ on the scale-one replica domes), where the positive macrosegregation zone is situated, are given in Table 19, supplemented by the values post-processed by two Areva NP contractors.

| Dome | UK upper | UA lower | UA upper | FA3 upper | FA3 lower | Deviation |
|---|----------|----------|----------|-----------|-----------|-----------|
| Areva NP instrument and procedure | 0.294 % | 0.317 % | 0.296 % | 0.314 % | 0.298 % | 0.023 % |
| Geostatistical post-processing n° 1: maximum | 0.291 % | 0.312 % | 0.296 % | 0.307 % | 0.298 % | 0.021 % |
| Geostatistical post-processing n° 1: max + 2 standard deviations | 0.301 % | 0.319 % | 0.317 % | 0.321 % | 0.310 % | 0.021 % |
| Geostatistical post-processing n° 2: maximum value | 0.279 % | 0.286 % | 0.294 % | 0.288 % | 0.297 % | 0.018 % |

Table 19: Maximum carbon content measurements on outer surface and statistical estimate of maximum from surface maps

On the basis of these values, Areva NP concludes that:

- the uncertainty on the maximum value is reduced by the geostatistical approach and varies between 3% and 5%, or 3% and 7%, depending on the contractor;
- the maximum values are within a variability range of 0.02% (or 10% in segregation ratio) for the two contractors. Areva NP therefore considers that there is a good level of consistency between the domes;
- the maximum carbon content values on the surface are very close, around 0.32%, including uncertainties;
- with the approach used by the first contractor, which takes account of all the extreme values of the measurements distribution²⁶, the surface segregation ratio of the domes of the Flamanville EPR reactor pressure vessel is covered by the values obtained on the scale-one replica domes, excluding uncertainties. The value of the Flamanville EPR reactor pressure vessel upper dome would appear to be the highest for values taking account of the uncertainties, owing to two significantly offset measurement values in the distribution range;
- with the approach of the second contractor, which eliminates high and isolated measurement points, the maximum segregation ratio on the surface of the lower dome of the Flamanville EPR reactor pressure vessel would appear to be the highest.

²⁴ Optical emission spectrometry, see section 4.1.1.4.

²⁵ Infrared combustion of metal chips, see section 4.1.1.4

²⁶ Considering very high, isolated carbon values more particularly has a significant impact on the surrounding values.

4.2.3. Parameters influencing the quenching effect

4.2.3.1. *Documentary and analytical elements*

With regard to the quenching effect, Areva NP studied the following manufacturing parameters for the three scale-one replica domes and the two domes of the Flamanville EPR reactor pressure vessel:

- the part thickness at the quality heat treatment stage, then after machining to the final profile;
- the quenching heat treatment operation performance conditions: the transfer time between the oven and the quenching tank, the type of quenching fluid, the quenching fluid temperature and tank stirring during quenching.

| | Upper domes | | | Lower domes | |
|---|-------------|--------|--------|-------------|--------|
| | FA3 | UA | UK | FA3 | UA |
| Austenitisation time before quenching | 7 h 36 | 7 h 25 | 7 h 13 | 8 h 17 | 7 h 10 |
| Transfer time between oven and quenching tank | 7 min | 5 min | 6 min | 5 min | 5 min |

Table 20: Quenching parameters for FA3, UA and UK upper domes and FA3 and UA lower domes

Thicknesses

For the domes in the test programme, in the central zone of the component, Table 21 summarises the thickness at the quality heat treatment stage, as well as the inner and outer face machining to obtain the final profile.

| | Dome | UK upper | UA lower | UA upper | FA3 upper | FA3 lower |
|-----------------|---|----------|----------|----------|-----------|-----------|
| Along part axis | Thickness during quality heat treatment | | | | | |
| | Machined thickness on inner face after quality heat treatment | | | | | |
| | Machined thickness on outer face after quality heat treatment | | | | | |
| | Final thickness | 232 mm | 147 mm | 232 mm | 232 mm | 147 mm |

Table 21: Machined thicknesses after quality heat treatment

Heat treatment operation performance conditions

With regard to the conditions for performance of the heat treatment operation, Areva NP states that:

- all the domes were quenched in water;
- the quenching fluid temperature has no significant impact, given the considerable difference between the fluid temperature and the temperature of interest of the part with regard to quenching performance (about 700°C);
- no impact is expected on the quality of the parts by the quenching stirring conditions;

- the transfer times between the oven and the quenching tank for the five domes are different (from 5 to 7 minutes) and well below the maximum time defined in the manufacturing technical programme (20 minutes).

Areva NP then used the manufacturing data (austenitisation temperature and duration, transfer time between oven and quenching tank, conditions for performance of the quench operation and thicknesses at hot forming stage before heat treatment) as the input data for a thermal calculation of the cooling rate after austenitisation.

Cooling rates obtained by numerical simulation

On the basis of the dimensions given in Table 21, Areva NP performed thermal calculations of the transfer phase from oven to quenching tank and then of the quenching operation, using two-dimensional models.

Figure 15 gives a comparison of the evolution of the cooling rate between the lower domes (quenching thickness of 250 mm) and the upper domes (290 mm), versus the distance to the quenching surface, that is before final machining.

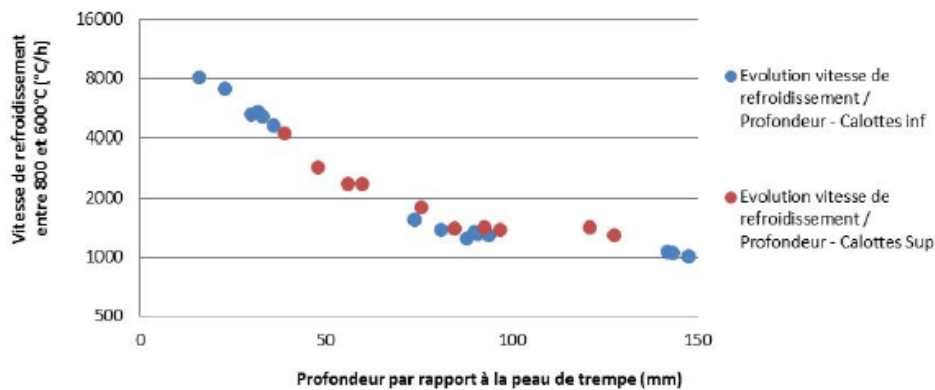

Figure 15: Results of numerical simulations of quenching operations: evolution of cooling rate during quenching versus distance to the surface

Cooling rate between 800 and 600 °C (°C/h)
 Evolution cooling rate / Depth - lower domes
 Evolution cooling rate / Depth – upper domes
 Depth in relation to the quenching surface (mm)

Despite the difference in quenching thicknesses, Areva NP considers that the quenching rates do not differ significantly, at the same distance from the quenching surface.

Table 22 presents the cooling rate results obtained by simulation at each depth of interest, determined after taking account of the final machining.

| | Dome | UK upper | UA lower | UA upper | FA3 upper | FA3 lower |
|---|---------------------------|----------|----------|----------|-----------|-----------|
| Cooling rate between 800°C and 600°C on final profile of part | Outer surface | | | | | |
| | ¼ thickness outer surface | | | | | |
| | Mid-thickness | | | | | |
| | ¼ thickness inner surface | | | | | |
| | Inner surface | | | | | |

Table 22: Cooling rates between 800°C and 600°C for characteristic depths

Figure 16 presents the cooling rate results obtained for the different pressure vessel domes, over the entire thickness of the domes.

Areva NP observes that, whatever the parts, the cooling rates at the centre (between one quarter thickness from the outer surface and one quarter thickness from the inner surface of the parts) change little. According to these results, Areva NP however concludes that the lower dome of the Flamanville EPR reactor pressure vessel appears to be in a more favourable situation than the other domes, with regard to the quarter thickness from the outer surface.

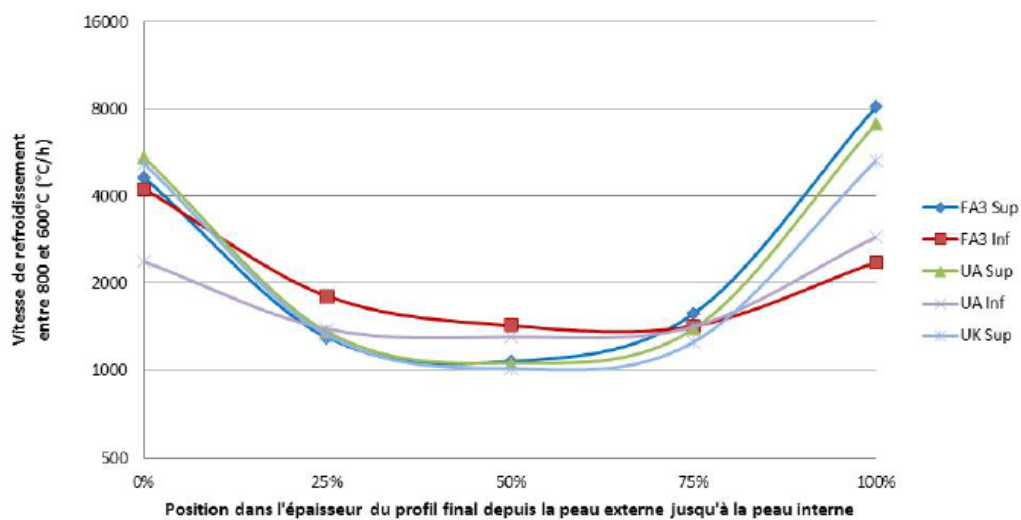

Figure 16: Results of numerical simulations of quenching operations: evolution of cooling rate during quenching versus thickness of domes

Cooling rate between 800 and 600°C (°C/h)
Position in thickness of final profile from outer surface to inner surface

4.2.3.2. Experimental data

Mechanical characteristics in acceptance zone

Areva NP compared the mechanical characteristics of the scale-one replica domes and the domes of the Flamanville EPR reactor pressure vessel, determined in the acceptance zone at the time of manufacturing. Then, during the test programme carried out in 2016, Areva NP determined the bending rupture energy and fracture toughness properties of these various domes in the acceptance zone.

The tensile and bending rupture energy properties (results of Charpy impact tests and RT_{NDT}), determined during the manufacturing acceptance tests, are presented in Table 23.

| Dome | UK upper | UA lower | UA upper | FA3 upper | FA3 lower |
|---|----------|----------|----------|-----------|-----------|
| $R_{p0.2\%}$ mean at T_{ambient} | 472 MPa | 469 MPa | 481 MPa | 457 MPa | 486 MPa |
| R_m mean at T_{ambient} | 613 MPa | 608 MPa | 626 MPa | 600 MPa | 622 MPa |
| A % min at T_{ambient} | 26 % | 24 % | 26 % | 25 % | 24 % |
| RT_{NDT} | -45 °C | -30 °C | -35 °C | -30 °C | -20 °C |
| KV mean at 0°C | 214 J | 246 J | 238 J | 184 J | 234 J |

Table 23: Mechanical properties in acceptance zone
extract from manufacturing completion report

Areva NP considers that these values correspond to those expected for this type of material. Although the tensile and bending rupture energy properties of the FA3 upper dome are the lowest of the five domes in the programme, Areva NP considers that they remain representative of the expected values and are comparable to the values obtained during the acceptance tests on the pressure vessel core shells from another supplier for the Finnish, English and French EPR reactor projects.

The bending rupture energy properties determined in the acceptance zone during the test programme are presented in Table 24.

| Dome | UK upper | UA lower | UA upper | FA3 upper | FA3 lower |
|------------------------|----------|----------|----------|-----------|-----------|
| T_{68J} (*) | -55 °C | -68 °C | -48 °C | -40 °C | -50 °C |
| KV ductile upper shelf | 214 J | 225 J | 218 J | 223 J | 213 J |

(*) T_{68J} is the temperature resulting from the Charpy transition curve for which the average bending rupture energy is 68 J

Table 24: Bending rupture energy characteristics in acceptance zone

Figure 17 represents the transition curves in the acceptance zone at one quarter thickness of the domes from the inner surface at the final profile.

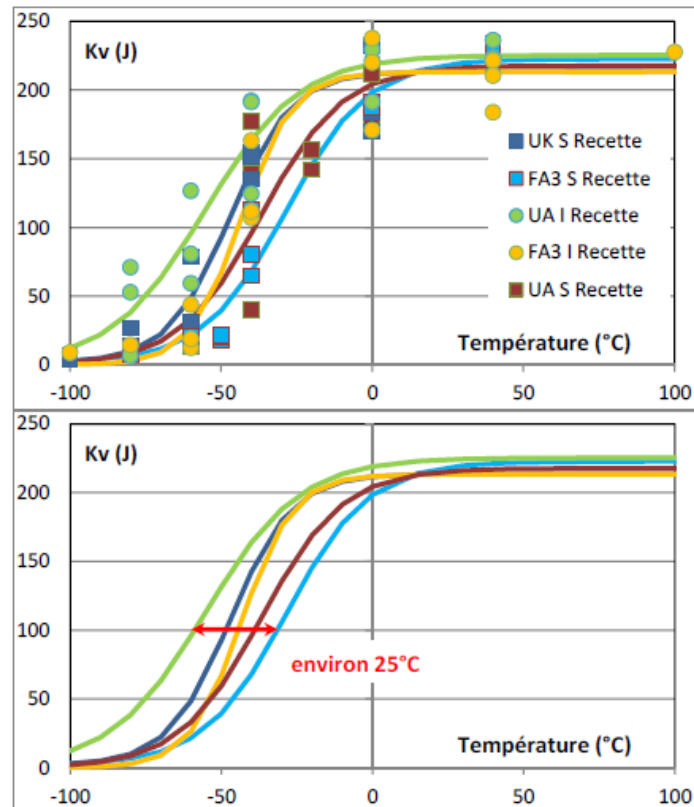

Figure 17: Transition curves in the acceptance zone

Recette = Acceptance

environ = about

Areva NP considers that the bending rupture energy properties determined in the acceptance zone during the test programme are consistent with the properties recorded during the manufacturing acceptance tests. Areva NP also considers that these values correspond to those expected for this type of material.

The transition temperatures resulting from the fracture toughness tests in the acceptance zone during the programme on the domes are presented in Table 25.

| Dome | UK upper | UA lower | UA upper | FA3 upper | FA3 lower |
|---------------|----------|----------|----------|-----------|-----------|
| $T_{env} (*)$ | -96 °C | -133 °C | -132 °C | -75 °C | -109 °C |
| $T_0 (**)$ | -115 °C | -134 °C | -126 °C | -94 °C | -126 °C |

(*) T_{env} is the index temperature of the curve in appendix ZG of the RCC-M code conservatively encompassing all the fracture toughness test results (Figure 18)

(**) T_0 is the reference temperature defined according to standard ASTM E1921

Table 25: Transition temperatures resulting from the fracture toughness tests in the acceptance zone

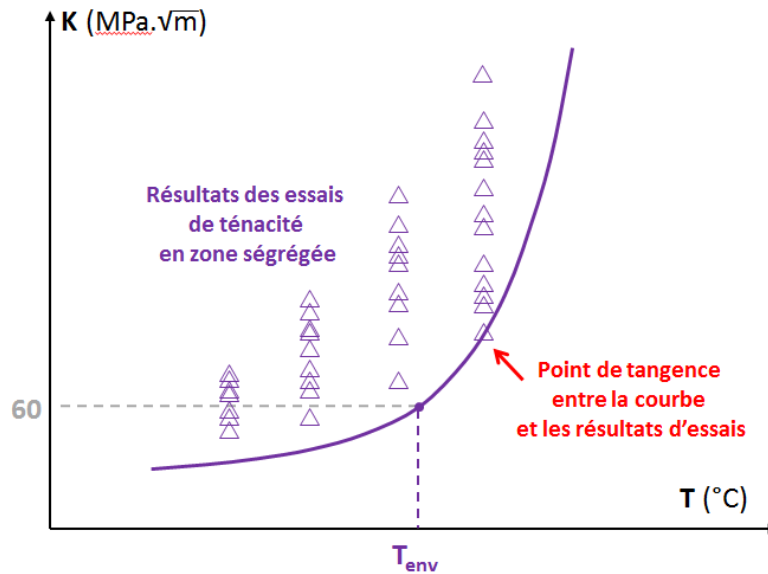

Figure 18: Principle for determining T_{env}

Results of fracture toughness tests in segregation zone
Tangency point between the curve and the test results

Areva NP considers that the variation in temperatures T_0 is representative of the variability of properties linked to the manufacturing process.

For all the domes tested, in the acceptance zone, the upper dome of the Flamanville EPR reactor leads to the highest T_0 temperature, with a value of -94°C by comparison with the lowest value of -134°C (UA lower dome). Areva NP considers that this value is indicative of excellent fracture toughness properties by comparison with the values normally encountered for this type of material.

Areva NP concludes that the comparison of the acceptance mechanical properties does not reveal any significant difference between the various domes and, according to its estimations obtained by calculation, confirms the similarity and performance of quenching for the different domes in the test programme and for the domes of the Flamanville EPR reactor pressure vessel.

4.2.4. Additional studies carried out by Areva NP

4.2.4.1. *Uncertainty analyses and statistics*

As the use of carbon content measurements requires a robust understanding of the uncertainties linked to the measurement techniques, Areva NP performed various additional analyses, already mentioned earlier in section 4.1.1.4:

- a methodology to evaluate the uncertainties in the carbon content measurement techniques;
- geostatistical²⁷ post-processing (by kriging²⁸) of the outer surface carbon content maps, in order to assess and minimise the uncertainties associated with the

²⁷ Geostatistics is the study of spatial (and temporal) phenomena in a probabilistic mathematical framework. This analysis method allows the estimation of quantities which have not been measured, with a quantification of the corresponding uncertainty. Geostatistics were originally developed for estimating ore grades for mining and then to characterise oil fields. It is now applied to all spatialised phenomena.

²⁸ Kriging is a geostatistical method for performing a spatial interpolation of the local carbon content.

measurements field.

Areva NP also carried out post-processing by kriging of the carbon contents in the thickness of the scale-one replica domes, in order to verify that the maximum contents on the outer surface are greater than the maximum contents in the thickness. Based on the values measured, Areva NP statistically observes that the carbon content increases from the inner surface to the outer surface, as expected.

4.2.4.1. Comparison of carbon contents in the depth of the scale-one replica domes

Through the test programme, Areva NP carried out carbon measurements:

- at different depths in the scale-one replica domes (see Appendix 10);
- on each of the specimens, sampled from all the domes and tested during the test programme;
- on the outer surface of all the domes.

Areva NP represented the maximum carbon content values observed at different depths on the scale-one replica domes according to their axial positioning in the parts.

These values were then projected into the coordinates of the reference bloom of the domes (see section 4.2.2.1), so that they can be compared in a common coordinates system.

Along the Y-axis, the carbon content is expressed:

- as an absolute value in Figure 19;
- as a value relative to the carbon content at pouring (segregation ratio) on Figure 20;
- as a value relative to the median value of the carbon content of the specimens sampled from the acceptance zone in Figure 21.

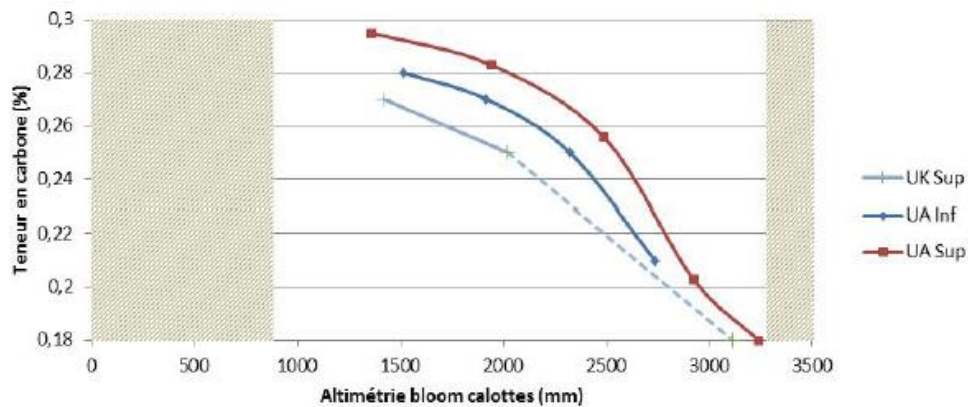

Figure 19: Evolution of the maximum carbon content

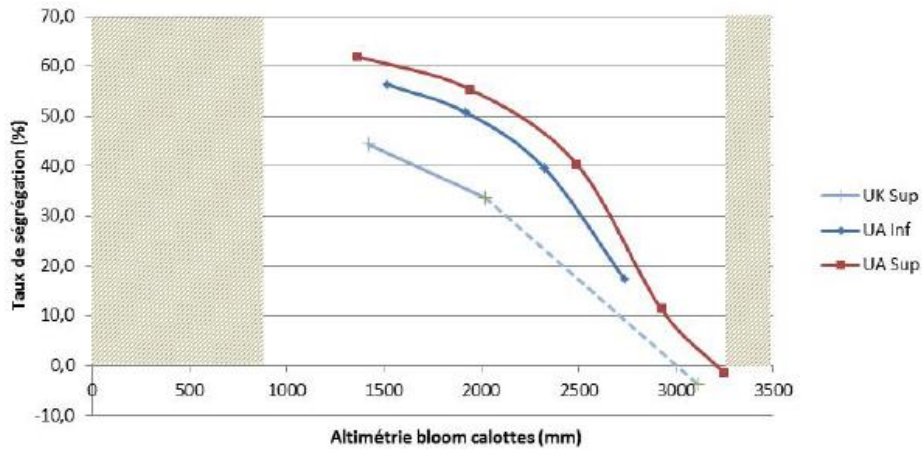

Figure 20: Evolution of maximum segregation ratio (carbon content relative to pouring)

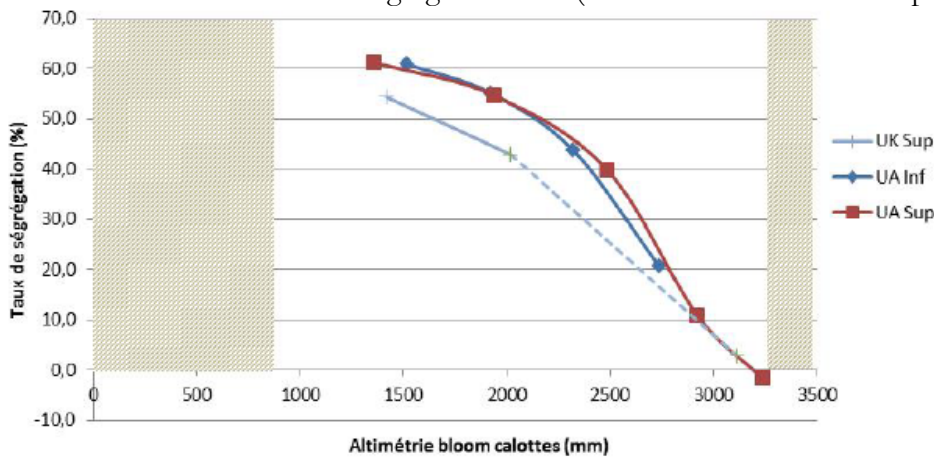

Figure 21: Evolution of maximum segregation ratio (carbon content relative to median acceptance value)

Teneur en carbone = Carbon content
 Taux de ségrégation = Segregation ratio
 Altimétrie bloom calottes = Bloom altimetry of domes

On these figures, Areva NP observes a general appearance that is identical, with a regular fall at equivalent heights. These trends are identical, whatever the choice of representations, segregation ratio or absolute carbon content value.

Areva NP also observes a certain dispersion between the three scale-one replica domes. Areva NP carried out variability analyses of the two representation parameters which are the positioning of the domes in the reference bloom (X-axis on Figure 22) and the segregation ratio (Y-axis on Figure 22), in order to show that the uncertainties of these two parameters (represented simultaneously in the form of rectangles in Figure 22) explain the differences observed between the various domes. Areva NP also observes that even when taking account of the variability of the two representation parameters, the segregation ratio on the inner surface of the upper domes is nominal.

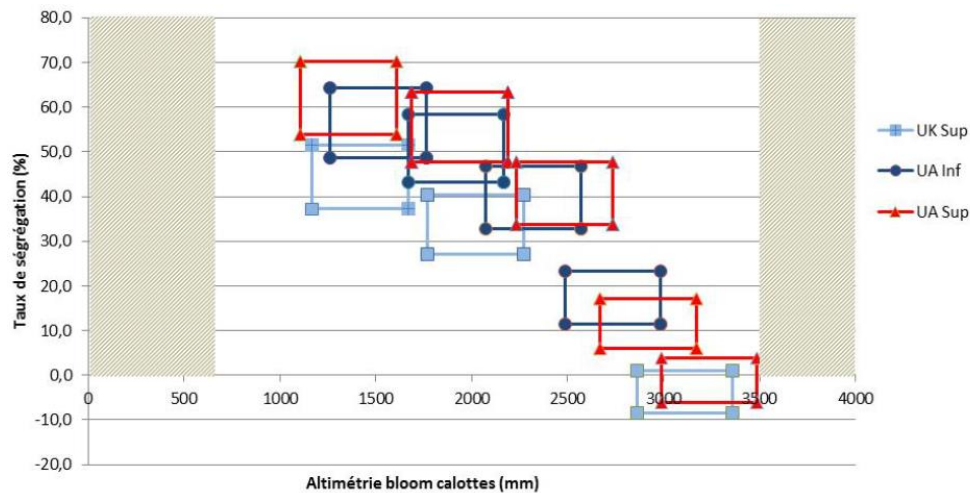

Figure 22: Evolution of maximum carbon content of scale-one replica domes taking account of uncertainties

Segregation ratio
Bloom altimetry of domes

4.2.4.2. Comparison with MOPPEC R&D bloom

In order to obtain additional information, Areva NP made a more detailed analysis of a bloom already examined in an R&D study (called the MOPPEC²⁹ bloom) and compared the carbon contents measured on this bloom with the carbon contents in the thickness of the scale-one replica domes.

The comparison was made by representing the carbon content profiles (converted into segregation ratios) in the thickness of the scale-one replica domes as a function of the altitude in the MOPPEC bloom (Figure 23), after converting the geometrical characteristics of the domes into the MOPPEC bloom coordinates system.

The representation of the segregation ratio profiles of the MOPPEC bloom, increased and reduced to take account of uncertainties, on Figure 23, was built from the measurements and studies performed on this bloom, that is:

- maps of the carbon content on a section plane passing through the bloom diameter, produced with a variable measurement pitch in order to focus on the positive macrosegregation zones;
- an estimation of the uncertainties to be taken into account in the study of this bloom from geostatistical post-processing by kriging, in order to build evolutions representative of maximum and minimum bounds (called “upper bound and lower bound post-processing curves” on Figure 23).

²⁹ MOPPEC: “Modèle de prédiction des propriétés des pièces écrasées” (model for predicting the properties of upset parts).

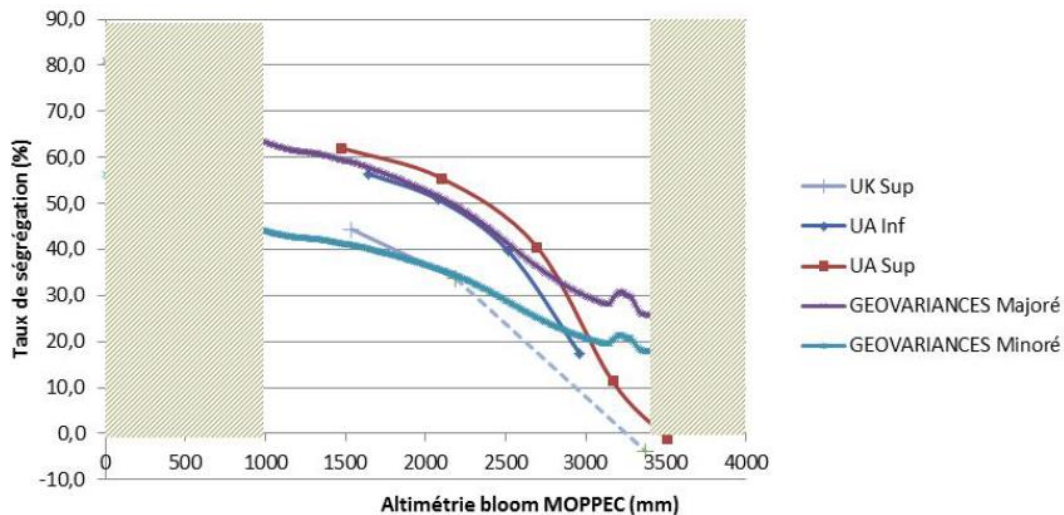

Figure 23: Evolution of the maximum carbon content – comparison of domes with post-processed, upper bound and lower bound MOPPEEC data

Segregation ratio
 UK upper
 UA lower
 UA upper
 Post-processed upper bound curve
 Post-processed lower bound curve
 MOPPEEC bloom altimetry

Areva NP observes:

- a similarity, in the upper part of the bloom, in the evolution of the positive macrosegregation, in terms of both content and position, between the scale-one replica domes and the MOPPEEC bloom;
- that the segregation ratios of the scale-one replica domes encompass the rates in the MOPPEEC bloom.

Areva NP considers that this additional analysis confirms the assessment of the low variability in segregations observed between the various scale-one replica domes.

4.2.5. Position of the rapporteur on the demonstration of representativeness

The rapporteur considers the choice of principal factors (carbon content and quenching effect) to be acceptable, along with the analysis of the parameters influencing them:

- comparison of the ingots pouring and solidification parameters;
- comparison of the forging and hot forming parameters and data;
- analysis of the relative positioning of the various domes in their reference bloom;
- comparison of the quenching and cooling rate parameters.

However, the rapporteur finds that the objective manufacturing data concerning the quenching operation (austenitisation temperature and duration, transfer time between oven and quenching tank, performance conditions and thicknesses at hot formed stage before heat treatment) are used as input data for a thermal calculation to estimate the cooling rates. The quenching effect is thus estimated by a calculation and is not directly measurable.

The rapporteur considers that the experimental data from physical tests performed at the moment of manufacturing or during the test programme are of greater interest, in that these data determine the variability between parts with regard to the positive macrosegregation. The rapporteur considers that the following are acceptable:

- comparison of carbon contents measured at pouring and on specimens in the acceptance zone;
- comparison of carbon contents measured on the outer surface;
- comparison of the mechanical properties in the acceptance zone.

The rapporteur considers that the demonstration of the representativeness of the scale-one replica domes, with respect to the domes of the Flamanville EPR reactor pressure vessel is based on a large quantity of parameters and data. This quantity of parameters and data exceeds that which is usually analysed for technical qualification of the production of materials today used in accordance with the ESPN order in reference [3]. The rapporteur however considers that this additional volume is necessary, on the one hand because we are dealing with a nonconformity and, on the other, because the available parameters on the parts in Flamanville are limited.

A technical qualification would rely on a few essential and influential parameters, such as the weight of the ingot and the discard ratio, and on the results of characterisation and mechanical tests aiming to intercept the risks of loss of homogeneity in terms of internal soundness and mechanical properties (carbon content profiles, tensile and impact strength tests at one-quarter and one-half the thickness).

The demonstration of representativeness proposed by Areva NP is based on a comparison of numerous other manufacturing parameters (for example the machined thicknesses and quenching cooling rates) and the test programme performed by Areva NP gives access to a far greater quantity of experimental data (more particularly the fracture toughness values and the various index temperatures).

The rapporteur considers that the conclusions of the additional analyses performed by Areva NP shed light on certain aspects of the demonstration. This is particularly the case of the geostatistical analysis of the carbon content measurements on the outer surface, for which the conclusions regarding the variability of the results between the five domes, of about 0.02%, show that the carbon contents are comparable. The rapporteur thus finds that, on the whole, the conclusions of the additional analyses performed by Areva NP confirm that the scale-one replica domes are representative of the Flamanville EPR reactor pressure vessel domes. The rapporteur does however consider that, because they are new, these additional analyses must be treated with precaution.

Finally, even if the rapporteur considers that the guarantees provided concerning representativeness are satisfactory, the work done by Areva NP nonetheless reveals certain differences between the domes studied, which are hard to assess quantitatively. The rapporteur more particularly identifies certain unfavourable elements:

- the various domes were manufactured at different periods (see Table 26) and for different customers;
- monitoring of the manufacturing of these domes was not ordered by ASN and, for the scale-one replica domes, the monitoring carried out by the customer did not implement the provisions applicable to French BNIs. In addition, the rapporteur did not have access to the conclusions of this monitoring;
- the carbon contents in the thickness and the mechanical properties in the positive

macrosegregation zone of the Flamanville EPR reactor pressure vessel domes are not available. The various domes cannot therefore be compared for direct parameters of interest and concentrate on intermediate parameters;

- despite the very similar manufacturing parameters, the mechanical characteristics comprise a natural variability which induces a degree of uncertainty which must be taken into account when making comparisons.

| Dome | UK upper | UA lower | UA upper | FA3 upper | FA3 lower |
|---------------------|----------|-----------|----------|-----------|-----------|
| Year of manufacture | 2013 | 2010/2011 | 2009 | 2006 | 2007 |

Table 26: Year of manufacture of the domes

The rapporteur therefore considers that, through the tests performed on samples taken from representative domes selected by Areva NP, the assessment of the properties of the material used for the domes of the Flamanville EPR reactor pressure vessel must follow an approach that is conservative enough to provide guarantees that have been proven in practice. These properties can then be used as input data for the fast fracture analyses, for which the method is codified and which incorporates its own conservative margins.

4.3. Results and interpretation of the test programme

The results obtained with the test programme and the corresponding interpretation by Areva NP, detailed below, are:

- the tensile properties;
- the bending rupture energy;
- the T_{NDT} and RT_{NDT} temperatures;
- the fracture toughness in the brittle behaviour and brittle-ductile transition domains
- the fracture toughness in the ductile behaviour domain;
- the fracture mechanisms.

4.3.1. Parameters influencing the mechanical properties

According to Areva NP, the variation in mechanical properties within a dome can be attributed to the chemical heterogeneity, via the variation in the carbon content and the variation in cooling rate at quenching in the thickness of this dome [35].

The positive macrosegregation zone is enriched with carbon and with alloy elements (manganese, molybdenum, silicon) which segregate in proportions approximately comparable to those of carbon. This zone is also enriched in impurities (sulphur, phosphorus). However, as the impurities concentration at pouring is very low for the domes of the Flamanville EPR reactor pressure vessel it also remains very low in the segregated zones. A slight increase in impurities in the segregated zone cannot contribute to a significant alteration in the mechanical behaviour before in-service ageing of the segregated zone by comparison with that of the acceptance zone. Consequently, Areva NP considers that carbon is the alloy element with the greatest influence on hardening and quenchability.

Areva NP thus interpreted the mechanical properties measured at one-quarter thickness ($1/4T$), at mid-thickness ($1/2T$) and at three-quarters thickness ($3/4T$) from the outer face of the scale-one replica domes with respect to the quenching rate and the carbon content.

Cooling rate during quenching in the domes

As previously mentioned, the quenching rate in the thickness of each dome in the scale-one replica programme was determined by Areva NP from thermal calculations. The estimation of the evolution of the cooling rate in the thickness of the domes following quenching, determined by Areva NP, is presented in Figure 16 on page 60. The quenching rate is maximal on the surfaces and rapidly decreases on moving away from the surfaces to one-quarter thickness behind these surfaces. The variation in quenching rate between one-quarter and three-quarters thickness is far less marked.

Carbon content in the thickness of the scale-one replica domes and extent of segregation zone

The carbon content in the test specimens sampled from the macrosegregation zones of the scale-one replica domes were measured by chemical analysis. For each sampling zone (400 mm x 400 mm slices) in each scale-one replica dome, Table 27 summarises the quench rates calculated and the minimum, maximum and average carbon contents measured on all the impact strength and fracture toughness test specimens (Table 27).

Areva NP considers the average carbon content to be a good indicator for characterising the behaviour of each sampling zone. For the zones in which the carbon variation was greater than $\pm 0.01\%$, the interpretation of the results rests on the utilisation of a population of data reduced to the data obtained on specimens with the carbon contents that are highest and the most homogeneous between specimens.

| | UK upper | | UA lower | | | UA upper | | |
|---------------------------------------|--------------|--------------|--------------|--------------|--------------|--------------|--------------|--------------|
| | ¼ T | ½ T | ¼ T | ½ T | ¾ T | ¼ T | ½ T | ¾ T |
| Quenching rate (°C/h) | 1318 | 1010 | 1386 | 1302 | 1414 | 1354 | 1058 | 1388 |
| Average carbon content (*) (%) | 0.254 | 0.221 | 0.266 | 0.254 | 0.221 | 0.279 | 0.268 | 0.227 |
| Min. carbon content (*) (%) | 0.243 | 0.196 | 0.251 | 0.224 | 0.200 | 0.258 | 0.251 | 0.206 |
| Max. carbon content (*) (%) | 0.268 | 0.241 | 0.276 | 0.267 | 0.246 | 0.296 | 0.282 | 0.247 |
| Standard deviation (%) | 0.005 | 0.011 | 0.005 | 0.009 | 0.013 | 0.009 | 0.007 | 0.011 |

(*) On the basis of chemical analyses performed on CT12,5 fracture toughness specimens and impact strength specimens.

Table 27: Carbon contents and quench rates at different depths in the UK upper, UA lower and UA upper domes where the samples were taken

The chemical analyses performed show that the carbon content decreases from the outer surface to the inner surface (Table 27, Figure 24). The segregation zone, with a maximum carbon content of 0.25% or more, extends from the outer surface to mid-thickness for the UK upper dome and reaches three-quarters of the thickness of the upper and lower UA domes, as shown in Figure 24. For information, the maximum carbon content is 0.32 %, measured on the outer surface of the UA upper dome [36]. This decrease is consistent with the measurements taken on the inner face of the scale-one replica domes, which show that segregation does not reach the inner surface.

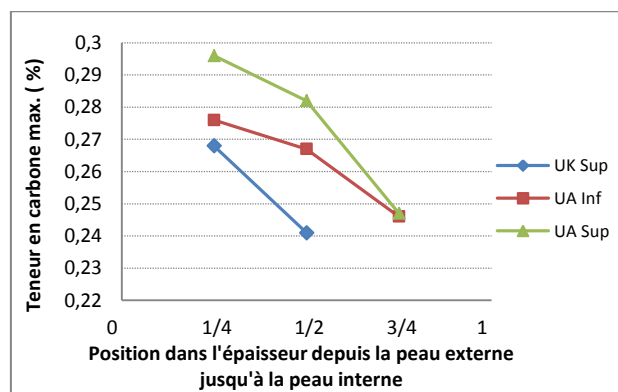

Figure 24: Maximum carbon content measured on specimens tested in the thickness of each scale-one replica dome

Max. carbon content
Position in thickness from outer surface to inner surface

4.3.2. Tensile properties

The tensile tests were performed and analysed in accordance with two standards:

- standard ISO 6892-1 of October 2009 for tests at ambient temperature;
- standard ISO 6892-2 of April 2011 for hot tests.

4.3.2.1. In acceptance zone

In the acceptance zone of the five domes which were characterised, the yield strength ($R_{p0.2}$) and the ultimate tensile strength (R_m) as a function of temperature change in a similar fashion and remain consistent with the characteristic data of a 16MND5 steel taken from the literature (FISTER tests [42]) as shown in Figure 25 [13]. The tensile characteristics of the UA upper dome are slightly higher at low temperature.

The yield strength in the acceptance zone of the five domes tested varies little. For example, it is between 435 and 462 MPa at ambient temperature and between 380 and 430 MPa at 330°C.

The ultimate tensile strength is between 568 and 584 MPa at ambient temperature and decreases at higher temperature.

For all the domes, the rupture elongation in the acceptance zone is 22% or higher within the temperature range -150°C to 330°C.

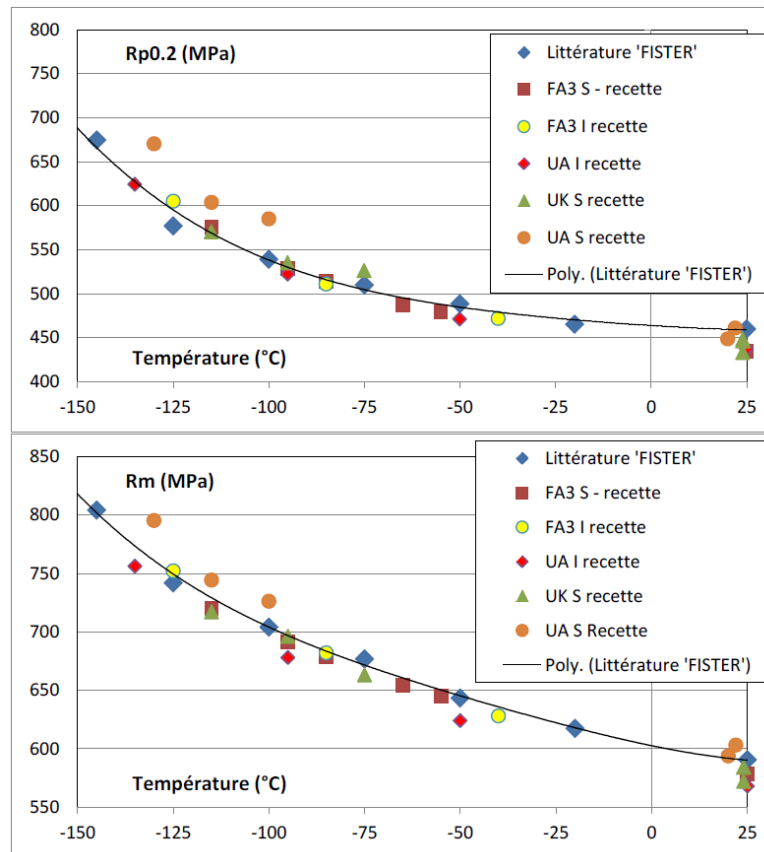

Figure 25: Evolution versus temperature of the yield strength $R_{p0.2}$ (top graph) and ultimate tensile strength R_m (bottom graph)

Littérature = Literature
recette = acceptance

4.3.2.2. In segregation zone

Areva NP indicates that the evolution curves for the yield strength ($R_{p0.2}$) and ultimate tensile strength (R_m) versus temperature are deduced from those obtained in the acceptance zone by a stress shift.

The yield strength in the segregation zone is systematically greater than or equal to that measured in the acceptance zone. As shown in Figure 26, the difference between the yield strength in the segregation zone and that in the acceptance zone ($\Delta R_{p0.2}$) decreases from one-quarter to three-quarters the thickness of the domes, which is correlated with a reduction in the carbon content in the thickness of the domes (Table 28). The same findings apply to the shift in the ultimate tensile strength (ΔR_m) (Table 28 and Figure 26).

Areva NP finds that the minimum fracture elongation obtained on three tests remains at least 20% at ambient temperature regardless of the carbon content of the sampling zone (quarter-thickness, mid-thickness or three-quarters thickness) (Table 28).

These results are in line with the specifications of the RCC-M code with regard to the tensile properties.

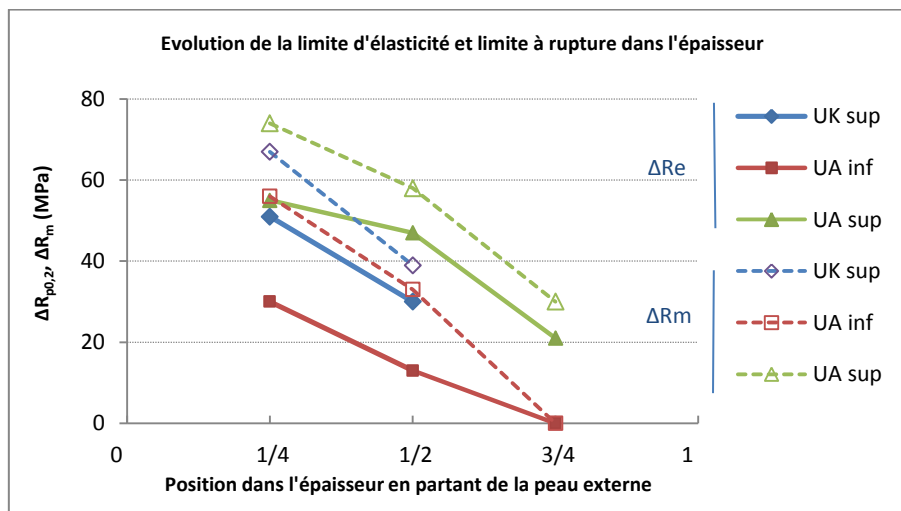

Figure 26: Shift in yield strength and ultimate tensile strength at 330°C in the segregation zone by comparison with the acceptance zone, as a function of position in the thickness
Evolution of yield strength and ultimate tensile strength in the thickness
Position in the thickness from the outer surface

| Zone | UK upper | | UA lower | | | UA upper | | |
|----------------------------|----------|-------|----------|-------|-------|----------|-------|-------|
| | ¼ T | ½ T | ¼ T | ½ T | ¾ T | ¼ T | ½ T | ¾ T |
| Quenching rate (°C/h) [12] | 1318 | 1010 | 1386 | 1302 | 1414 | 1354 | 1058 | 1388 |
| %C ave. (*) | 0.254 | 0.221 | 0.263 | 0.245 | 0.205 | 0.271 | 0.262 | 0.219 |
| Standard deviation (%C) | 0.005 | 0.006 | 0.005 | 0.012 | 0.008 | 0.007 | 0.005 | 0.003 |
| $\Delta R_{p0.2}$ (MPa) | 51 | 30 | 30 | 13 | 0 | 55 | 47 | 21 |
| ΔR_m (Mpa) | 67 | 39 | 56 | 33 | 0 | 74 | 58 | 30 |
| A % min ambient | 20 | 24 | 21 | 20 | 24 | 21 | 20 | 24 |

(*) value taken from measurements on tensile test specimen

Table 28: Shift in yield and ultimate tensile strengths at 330°C and minimum elongation [13]

4.3.3. Impact strength properties

The impact strength, or Charpy tests, were performed in accordance with standard ISO 148-1 of January 2011 [34].

For Areva NP, the appearance of the bending rupture energy curves in the segregation zone of the UK upper, UA lower and UA upper domes is comparable. They are shifted to higher temperatures by comparison with the curves obtained in the acceptance zone (Figure 27). The T_{68j} temperature changes as a function of the position in the thickness of the domes (Figure 28) and therefore as a function of the carbon content (Table 29). The maximum deviation between the temperature T_{68j} measured in the segregation zone and that measured in the acceptance zone (ΔT_{68j}) is about 60°C, the value determined for the UA upper dome with the highest carbon content (Table 29 and Figure 29).

Areva NP notes that the ductile upper shelf is lower than the acceptance zone, as shown in Figure 27. The hot bending rupture energy (ductile upper shelf) in the segregation zone, for all the domes, is between 170 J and 200 J (Table 29).

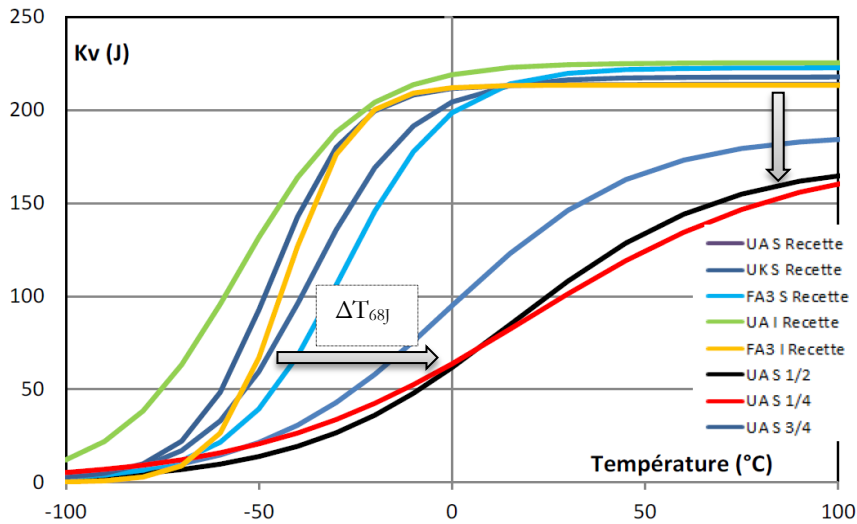

Figure 27: Comparison of transition curves in segregation zone by comparison with the acceptance zone for the UA Upper dome with the highest carbon content

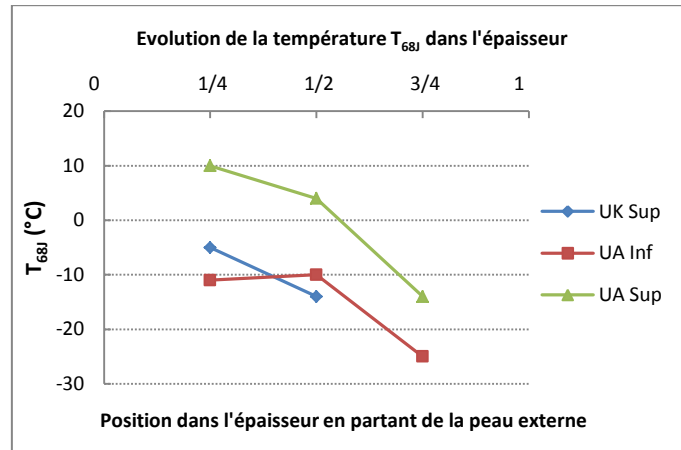

Figure 28: Evolution of T_{68J} as a function of the position in the thickness of the scale-one replica domes

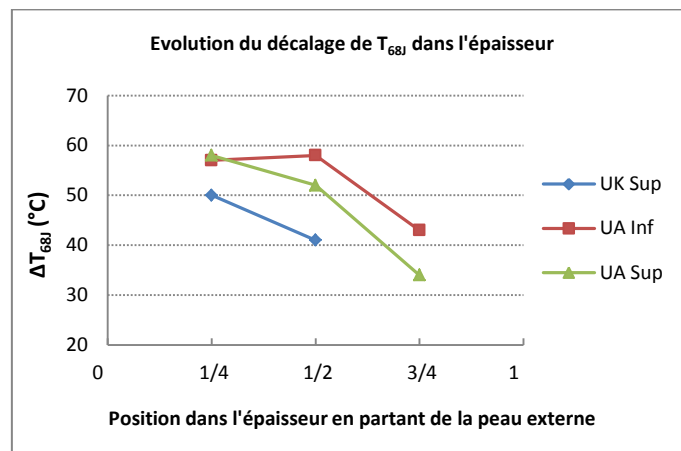

Figure 29 : Evolution of shift in T_{68J} as a function of the position in the thickness of the scale-one replica domes

Evolution of temperature T_{68J} in the thickness
Position in the thickness from the outer surface

| | UK upper | | UA lower | | | UA upper | | |
|----------------------------|----------|-------|----------|-------|-------|----------|-------|------|
| Zone | ¼ T | ½ T | ¼ T | ½ T | ¾ T | ¼ T | ½ T | ¾ T |
| Quenching rate (°C/h) [12] | 1318 | 1010 | 1386 | 1302 | 1414 | 1354 | 1058 | 1388 |
| C ave. (%) (*) | 0.252 | 0.225 | 0.265 | 0.258 | 0.227 | 0.281 | 0.27 | 0.23 |
| Standard deviation %C (%) | 0.005 | 0.01 | 0.006 | 0.006 | 0.006 | 0.008 | 0.004 | 0.01 |
| T _{CV} (°C) | 20 | 5 | 5 | 5 | -20 | 30 | 30 | 0 |
| T _{68J} (°C) | -5 | -14 | -11 | -10 | -25 | 10 | 4 | -14 |
| ΔT _{68J} (°C) | 50 | 41 | 57 | 58 | 43 | 58 | 52 | 34 |
| Ductile upper shelf (J) | 185 | 196 | 187 | 181 | 185 | 176 | 172 | 186 |

(*) value taken from measurements on impact strength test specimen

Table 29: Summary of results taken from the impact strength tests in segregation zone (T_{CV}, T_{68J}, ΔT_{68J} and bending rupture energy level at ductile upper shelf) [13]

Areva NP remarks that the carbon content varies little within the impact test specimens sampled at one-quarter thickness of the UK and UA domes. The variation is less than $\pm 0.01\%$ (Table 29). To construct the impact strength curve at mid-thickness and three-quarters thickness of the UA lower dome, the variation in carbon content between the test specimens being greater than $\pm 0.01\%$, Areva NP chose a data population reduced to that taken from the tests on specimens with the highest carbon contents, in order to reduce the carbon content variation. This enables Areva NP to consider that the transition temperatures defined from the impact strength curves are representative of the behaviour of the material with a carbon content corresponding to the average value in the segregation zone at the depth considered [13].

During a previous test campaign from 2014 to the beginning of 2016 [8], a core sample taken from the central part of the UA upper dome was also characterised. This characterisation showed that the bending rupture energy changes little from the surface to three-quarters of the thickness and then increases significantly as of three-quarters of the thickness. This considerable variation in bending rupture energy according to depth is ascribed to the conflicting effects of the quenching rate and the carbon content (Figure 30). For Areva NP, the effect of the carbon content, which tends to weaken bending rupture energy, is offset by the quenching effect, which is increasingly beneficial the closer one gets to the surface, which tends to increase it.

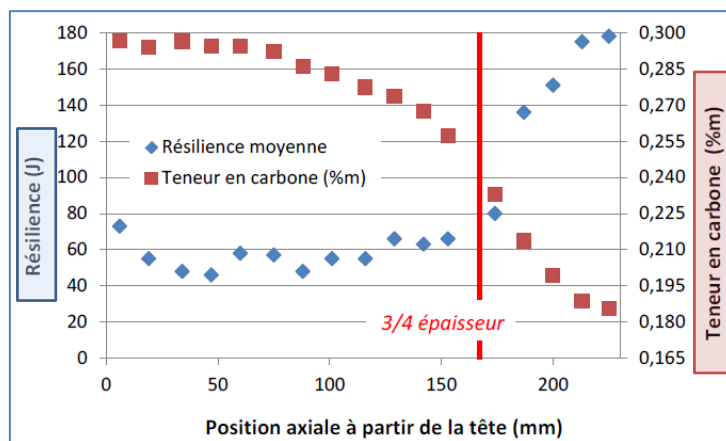

Figure 30: Evolution of bending rupture energy and carbon content along the axis of the core sample taken from the UA Upper dome – impact test performed at 0°C [8]

Bending rupture energy
Average bending rupture energy
Carbon content
3/4 thickness
Carbon content (%m)
Axial position from the top (mm)

4.3.4. Temperatures T_{NDT} and RT_{NDT}

The nil ductility transition temperature, T_{NDT} , was determined from the drop-weight tests performed in accordance with the 1975 ASTM E208, as per the RCC-M code, in order to maintain the baseline reference used for all the French reactor pressure vessels in operation [34].

T_{NDT} is the temperature above which brittle fracture cannot be triggered from a small dimension flaw under a stress close to the yield strength of the material. The drop-weight test is an impact bending test of a rectangular specimen with a weld bead notched beforehand with a saw. A maximum of eight specimens are generally needed (for four test temperatures) to determine the T_{NDT} . The tests are performed by gradually approaching the temperature at which at least one of the two specimens, tested at the same temperature, breaks. T_{NDT} then corresponds to this temperature.

The RT_{NDT} transition temperature is obtained by combining the results of the drop-weight tests with the results of the impact strength tests performed on V-notch impact test specimens, in accordance with standard ISO 148-1 of January 2011 [34]. The tests are performed at an initial temperature of $T_{\text{NDT}} + 33^{\circ}\text{C}$. RT_{NDT} is equal to the test temperature, minus 33°C ³⁰, which – for each of the three specimens tested at this temperature – enables the following two criteria to be met:

- the bending rupture energy is at least 68 J;
- the lateral expansion is at least 0.9 mm.

³⁰ If the two criteria are not met at a given temperature, new impact strength tests are performed, with the addition of 5°C until they are.

These two criteria were met for all the tests performed on the samples taken from the scale-one replica domes, regardless of the zone in question, whether acceptance or segregation. For all the characterisations performed on the scale-one replica domes of the Areva NP test programme, the RT_{NDT} transition temperature is therefore equal³¹ to T_{NDT} .

4.3.4.1. In acceptance zone

The RT_{NDT} in the acceptance zone is between -20°C and -45°C for all the domes assessed (Table 30). In the acceptance zone, the carbon content is about 0.18%.

| Dome | FA3 upper | FA3 lower | UK upper | UA lower | UA upper |
|---------------------------|-----------|-----------|----------|----------|----------|
| $T_{NDT} = RT_{NDT}$ (°C) | -30 | -20 | -45 | -30 | -35 |

Table 30: Transition temperature in the acceptance zone

4.3.4.2. In segregation zone

According to Areva NP, although the carbon content varies notably in the segregation zone of each scale-one replica dome, there is very little dispersion of the values of RT_{NDT} measured within each of these domes at different depths in the segregation area (Table 31, Table 32, Table 33) [13]. The variation of RT_{NDT} within a given dome is 5°C between quarter-thickness and mid-thickness (Figure 31).

| Slice | Position in the thickness | %C ave(*) | %C min(*) | % C max(*) | RT_{NDT} (°C) |
|-------|---------------------------|-----------|-----------|------------|-----------------|
| 2 | 1/7 T | 0.257 | 0.251 | 0.266 | 0 |
| 4 | 1/3 T | 0.250 | 0.244 | 0.254 | -5 |
| 5 | 3/7 T | 0.239 | 0.231 | 0.244 | -5 |
| 7 | 5/8 T | 0.199 | 0.190 | 0.206 | -15 |

(*) measured on drop-weight specimen

Table 31: UK upper dome – Evolution of RT_{NDT} as a function of carbon content

| Slice | Position in the thickness | %C ave. (*) | %C min (*) | % C max (*) | RT_{NDT} (°C) |
|-------|---------------------------|-------------|------------|-------------|-----------------|
| 2 | 1/4 T | 0.257 | 0.251 | 0.262 | -5 |
| 3 | 1/2 T | 0.237 | 0.226 | 0.259 | 0 |
| 4 | 3/4 T | 0.217 | 0.199 | 0.238 | -10 |

(*) measured on drop-weight specimen

Table 32: UA lower dome – Evolution of RT_{NDT} as a function of carbon content

³¹ Which is generally observed for this type of steel in an acceptance zone.

| Slice | Position in the thickness | %C ave. (*) | %C min (*) | %C max (*) | RT _{NDT} (°C) |
|-------|---------------------------|-------------|------------|------------|------------------------|
| 2 | 1/7 T | 0.283 | 0.277 | 0.290 | 5 |
| 4 | 1/3 T | 0.278 | 0.269 | 0.287 | 5 |
| 5 | 3/7 T | 0.270 | 0.257 | 0.288 | 5 |
| 7 | 5/8 T | 0.247 | 0.236 | 0.261 | 0 |
| 9 | 5/6 T | 0.198 | 0.194 | 0.203 | -20 |

(*) measured on drop-weight specimen

Table 33: UA upper dome – Evolution of RT_{NDT} as a function of carbon content

Taking all the domes together, the RT_{NDT} in the segregation zone are between -10°C and 5°C. The dispersion is thus significantly smaller than the dispersion of RT_{NDT} in the acceptance zone for all the domes (Table 30).

Areva NP underlines that at 30 mm from mid-thickness towards the inner surface of the UK upper dome, the RT_{NDT} is -15°C (Figure 31). For the UA upper dome, for which segregation reaches three-quarters of the thickness, the measurements made between three-quarters thickness and the inner surface lead to an RT_{NDT} of -20°C, equal to the maximum value specified by the RCC-M code (Figure 31).

Finally, Areva NP notes that the difference between the RT_{NDT} in the segregation zone (between one-quarter and three-quarters of the thickness) and that in the acceptance zone is between 20°C and 45°C (Figure 32). Areva NP concludes from these measurements that the increase in carbon content leads to a significant increase in the RT_{NDT}.

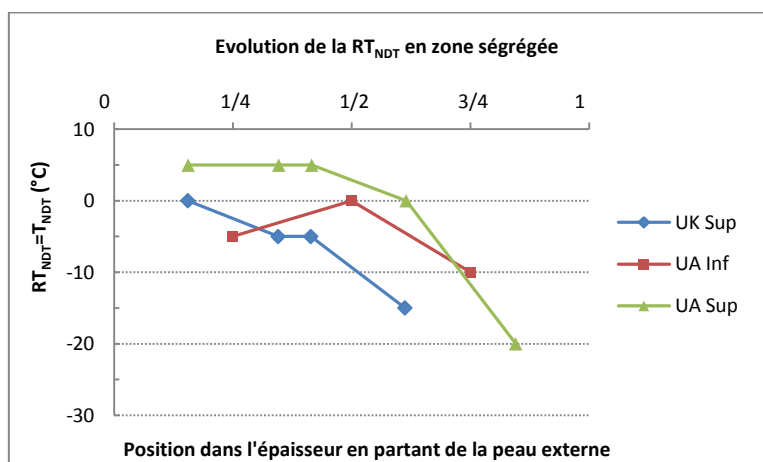

Figure 31: Evolution of the RT_{NDT} in segregation zone in the thickness of the scale-one replica domes

Evolution of RT_{NDT} in segregation zone
Position in the thickness starting from the outer surface

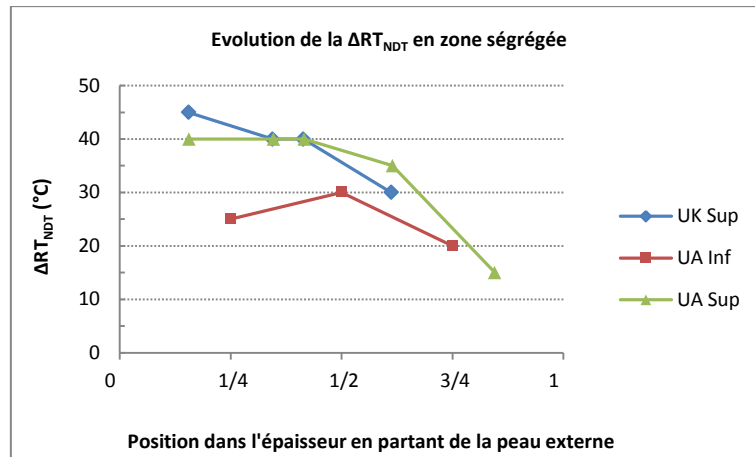

Figure 32: Evolution of the RT_{NDT} shift in segregation zone in the thickness of the scale-one replica domes

Evolution of ΔRT_{NDT} in segregation zone
Position in the thickness starting from the outer surface

Areva NP remarks that the carbon content varies little within the slices of the UK and UA upper domes from which the drop weight specimens were sampled. It varies by plus or minus 0.01% (Table 31, Table 32, Table 33). Areva NP therefore considers that the T_{NDT} measured in each slice is representative of a material with a carbon content corresponding to the average of the zone from which the drop weight specimens were sampled, presented in Table 31, Table 32 and Table 33.

For the UA lower dome, Areva NP also notes that there is slight dispersion of the carbon content in slice 2, corresponding to one-quarter thickness, but that the variation in the carbon content at mid-thickness is greater.

In short, Areva NP notes that the T_{NDT} measured in the segregated zone is greater than the maximum value anticipated at the design stage, known as the *design* T_{NDT} , of -20°C .

For Areva NP, the increase in the T_{NDT} in the segregation zone would appear to be consistent with the trends observed in the tensile and impact strength tests. However, Areva NP does not only attribute the increase in T_{NDT} to a loss of the material's ability to withstand flaw initiation and the propagation of a crack initiated on this flaw. Areva NP attributes the increase in T_{NDT} in part to the hardening induced by the higher carbon content in the segregation zone than in the acceptance zone. According to the Areva NP estimates, this hardening – which leads to a rise in the yield strength – results in a 10% increase in loading and in the energy to be dissipated by cracking during the drop-weight test, this latter being tested with imposed deformation [13]. The flaw loading conditions being harsher in the segregation zone than in the acceptance zone, Areva NP considers it to be logical that the hardening phenomenon contributes to the fact that the T_{NDT} in the segregation zone is higher than in the acceptance zone.

4.3.5. Fracture toughness in the brittle-ductile transition domain

The fracture toughness tests were performed and analysed in accordance with standard ASTM E1921 of 2013. This standard presents the protocol of the Master Curve approach. This approach, which takes advantage of the knowledge acquired on fracture mechanisms through cleavage of ferritic steels, is used to determine the statistical distribution of the toughness of a ferritic steel as a function of temperature.

The Master Curve (MC) is an empirical curve associated with a 50% fracture probability, which describes the evolution versus temperature of the toughness of ferritic steels in the brittle-ductile behaviour domain. This curve is indexed on the *reference* temperature T_0 , which is the temperature at which the toughness is in theory equal to $100 \text{ MPa}\cdot\text{m}^{0.5}$. This reference temperature T_0 is determined by fracture toughness tests. Within a zone which can be considered to be homogeneous in terms of microstructure and chemical composition, about ten toughness tests are sufficient to determine T_0 precisely.

In a manner comparable to the RT_{NDT} , the lower the reference temperature T_0 of a ferritic steel, the greater its toughness. Similarly, an increase in it indicates a drop in toughness. The variation in temperature T_0 is thus a parameter for assessing the toughness of segregation zones by comparison with the acceptance zone.

Master Curve tolerance bounds were also defined for various fracture probabilities (for example 5% and 95%) (this is illustrated using data from the scientific literature in Figure 33). In the test programme on the pressure vessel domes, the positioning of the toughness data in relation to these bounds is a means of assessing the statistical dispersion of the toughness test results, as compared with what is expected for a ferritic steel. The number of tests performed to characterise the toughness at different depths in the segregation zones of the scale-one replica domes was notably increased in relation to the requirements of standard ASTM E1921, in order to cover the temperature domain in which the behaviour is mixed brittle-ductile.

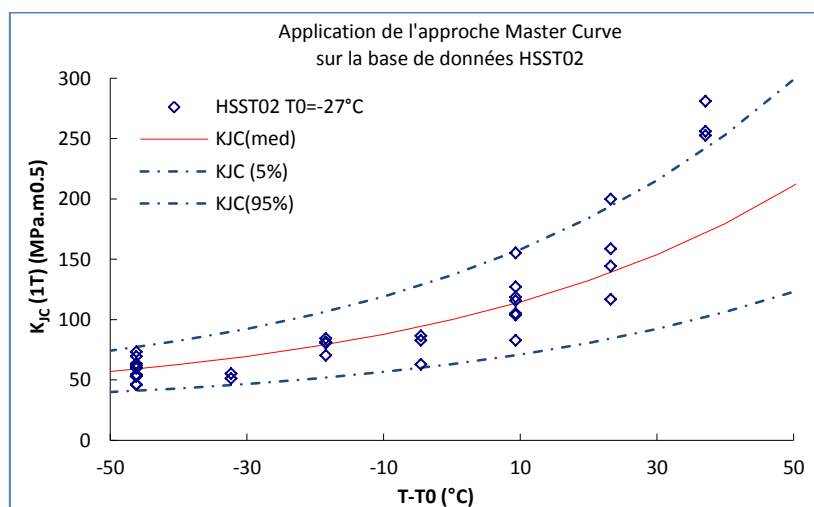

Figure 33: Application example given by the rapporteur for the Master Curve approach
Tolerance bounds at 50%, 5% and 95%

Application of the Master Curve approach on the basis of HSST02 data

The toughness data were also positioned in relation to the ZG6110 toughness curve prescribed by the RCC-M code (Figure 4), which is the reference curve used in the design and operation of French nuclear reactors. This empirical curve gives the evolution of fracture toughness versus temperature ($T-RT_{NDT}$). It was established during the 1970s and then revised in 2000, to constitute a lower bound of a thousand items of toughness data for ferritic steels of a grade equivalent to or very similar to the grade of steel used in the EPR reactor pressure vessel domes.

The Areva NP interpretation of the fracture toughness test results in the acceptance zone and segregation zone is detailed below.

4.3.5.1. In acceptance zone

Areva NP notes that in the acceptance zone of the five domes assessed, the reference temperatures T_0 are very low (Table 34) and comparable to those taken from the literature for comparable grades of steel, that is:

- -84°C for the American Shoreham vessel [38];
- -95°C for the EDF base drawn up from tests performed on a sheet of 18MND5 grade steel [39];
- -122°C for a shell slug made of 16MND5, assessed by CEA [40];
- -90°C for the European database obtained from tests performed on the steel of a vessel manufactured in Germany [41].

Areva NP determined the optimum index temperature T_{env} for the RCC-M curve M (see Figure 18), which optimally encompasses the fracture toughness results. Areva NP finds that this temperature appears to be closer to the T_0 temperature than the RT_{NDT} which is far higher (Table 34).

| Dome | FA3 upper | FA3 lower | UK upper | UA lower | UA upper |
|-------------------|-----------------------|------------------------|------------------------|------------------------|------------------------|
| T_0 | -94°C | -126°C | -115°C | -134°C | -126°C |
| T_{env} | -75°C | -109°C | -96°C | -133°C | -132°C |
| RT_{NDT} | -30°C | -20°C | -45°C | -30°C | -35°C |

Table 34: Reference temperature and optimum index temperature of the RCC-M curve in the acceptance zone

4.3.5.2. In segregation zone

In the segregation zone for all the scale-one replica domes, Areva NP observes that the reference temperature T_0 is between -70°C and -50°C between one-quarter and mid-thickness (Table 35 and Figure 35) and reaches -85°C at three-quarters the thickness of the UA domes. Areva NP also notes that T_0 varies very little from one-quarter to mid-thickness of the same dome (Table 35 and Figure 35).

Areva NP also finds that the difference with the acceptance zone (ΔT_0) is comparable to that observed on temperature ΔT_{68j} (Table 35).

| Zone | UK upper | | UA lower | | | UA upper | | |
|---|-----------------|-----------------|-----------------|-----------------|-----------------|-----------------|-----------------|-----------------|
| | $\frac{1}{4} T$ | $\frac{1}{2} T$ | $\frac{1}{4} T$ | $\frac{1}{2} T$ | $\frac{3}{4} T$ | $\frac{1}{4} T$ | $\frac{1}{2} T$ | $\frac{3}{4} T$ |
| Quenching rate ($^{\circ}\text{C}/\text{h}$) [12] | 1318 | 1010 | 1386 | 1302 | 1414 | 1354 | 1058 | 1388 |
| %C ave | 0.254 | 0.221 | 0.267 | 0.255 | 0.221 | 0.277 | 0.268 | 0.225 |
| Standard deviation (%C) | 0.005 | 0.011 | 0.004 | 0.007 | 0.014 | 0.008 | 0.008 | 0.011 |
| T_0 ($^{\circ}\text{C}$) | -63 | -64 | -71 | -66 | -85 | -54 | -50 | -85 |
| ΔT_0 ($^{\circ}\text{C}$) | 52 | 51 | 63 | 68 | 49 | 72 | 76 | 41 |
| ΔT_{68j} ($^{\circ}\text{C}$) | 50 | 41 | 57 | 58 | 43 | 58 | 52 | 34 |

Table 35: Reference temperature T_0 and shift of T_0 in the thickness of the scale-one replica domes

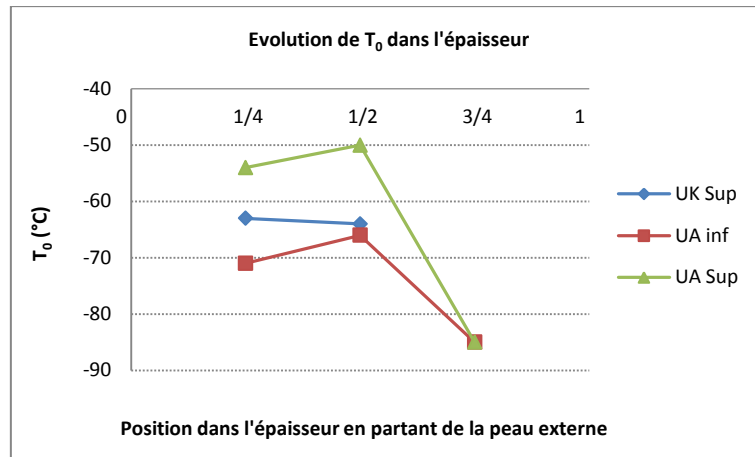

Figure 34: Evolution of T_0 in the thickness of the UK, UA domes

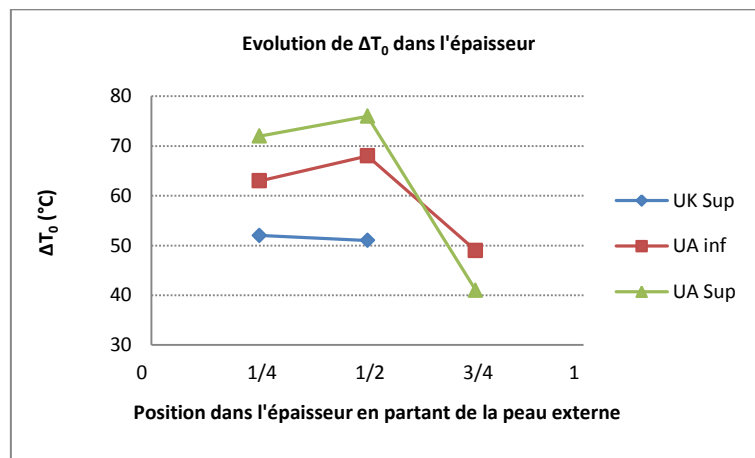

Figure 35: Evolution of the T_0 shift between the segregation zone and the acceptance zone in the thickness of the UK, UA domes

Evolution of T_0 in the thickness
Position in the thickness starting from the outer surface

Areva NP positioned the fracture toughness data from the samples taken from the acceptance zone and at one-quarter thickness of the segregation zone in the scale-one replica domes in relation to the Master Curve tolerance bounds at 1% and 99% (Figure 36) [13]. Areva NP observes that the distribution of these fracture toughness data is comparable to that expected for a ferritic steel described by the Master Curve approach. The same applies for the toughness data from the tests on samples taken at mid-thickness of the UK and UA domes in the segregation zone. Areva NP concludes that the segregation zone has a conventional fracture behaviour and that the hardening linked to carbon segregation essentially leads to a shift in the reference temperature T_0 .

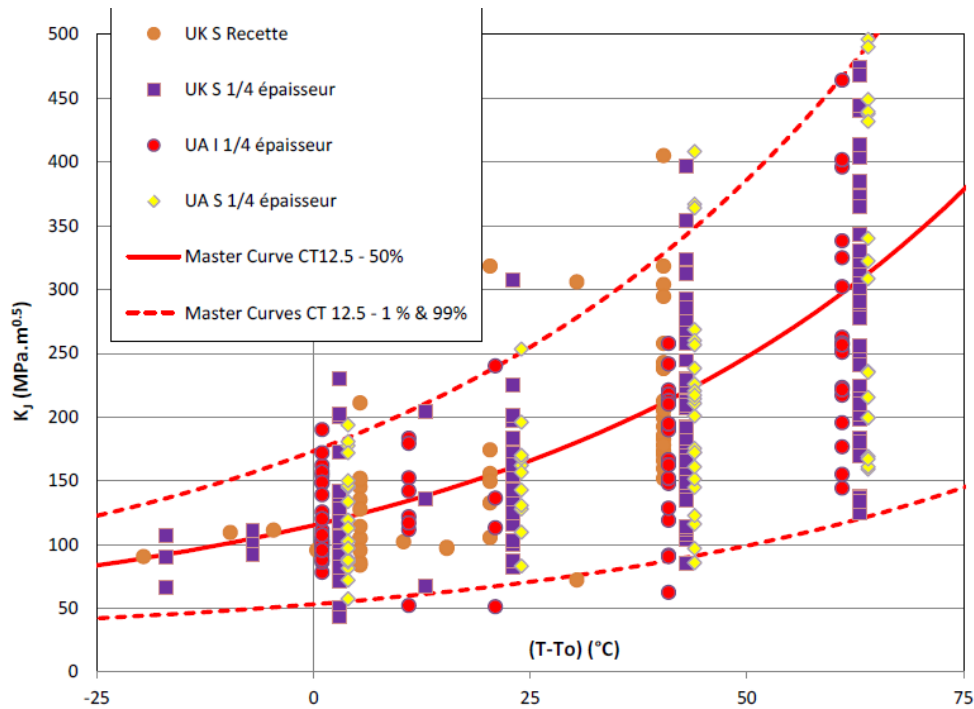

Figure 36: Positioning of the fracture toughness data for the specimens sampled at one-quarter thickness of the scale-one replica domes [13]

UK U Acceptance
 UK U ¼ thickness
 UA L ¼ thickness
 UA U ¼ thickness

The fracture toughness data were also positioned by Areva NP in relation to the RCC-M toughness curve indexed on various temperatures [13].

Areva NP checked that the RCC-M curve indexed on the index temperature, known as *LDS 9*, encompasses the toughness results in the segregation zone (Figure 37 and Figure 38). The *LDS 9* index temperature is equal to the end-of-life RT_{NDT} adopted in the design (30°C) by Areva NP, minus the shift linked to thermal ageing and stress ageing (15°C) and the maximum difference between the acceptance RT_{NDT} for the domes of the Flamanville EPR reactor pressure vessel and that of each of the three scale-one replica domes. Taking account of the maximum acceptance RT_{NDT} obtained in the acceptance zone of the Flamanville domes, this leads to an *LDS 9* index temperature, equal to the acceptance RT_{NDT} plus 35°C. It entails a 35°C shift to the right of the RCC-M curve indexed on the acceptance RT_{NDT} .

Areva NP also observed on Figure 37 and Figure 38 that not all the toughness data are covered by the RCC-M curve indexed on the acceptance RT_{NDT} . Thirteen fracture toughness data of the available 614 for the segregation zone appear below the RCC-M toughness curve indexed on the acceptance RT_{NDT} (Figure 37).

In addition to determining the T'_{NDT} and the RT_{NDT} in the segregation zone, Areva NP determined the index temperature optimally encompassing all the fracture toughness measurements in the segregation zone. The curve encompasses all the fracture toughness data for the segregation zone if the acceptance RT_{NDT} is increased by de 20°C (Figure 37 and Figure 38).

The RCC-M curve indexed on the RT_{NDT} in the segregation zone, equal to T_{NDT} , encompasses all the toughness data, this being greater than or equal to the acceptance RT_{NDT} plus 20°C (ΔRT_{NDT} in segregation zone ≥ 20 °C).

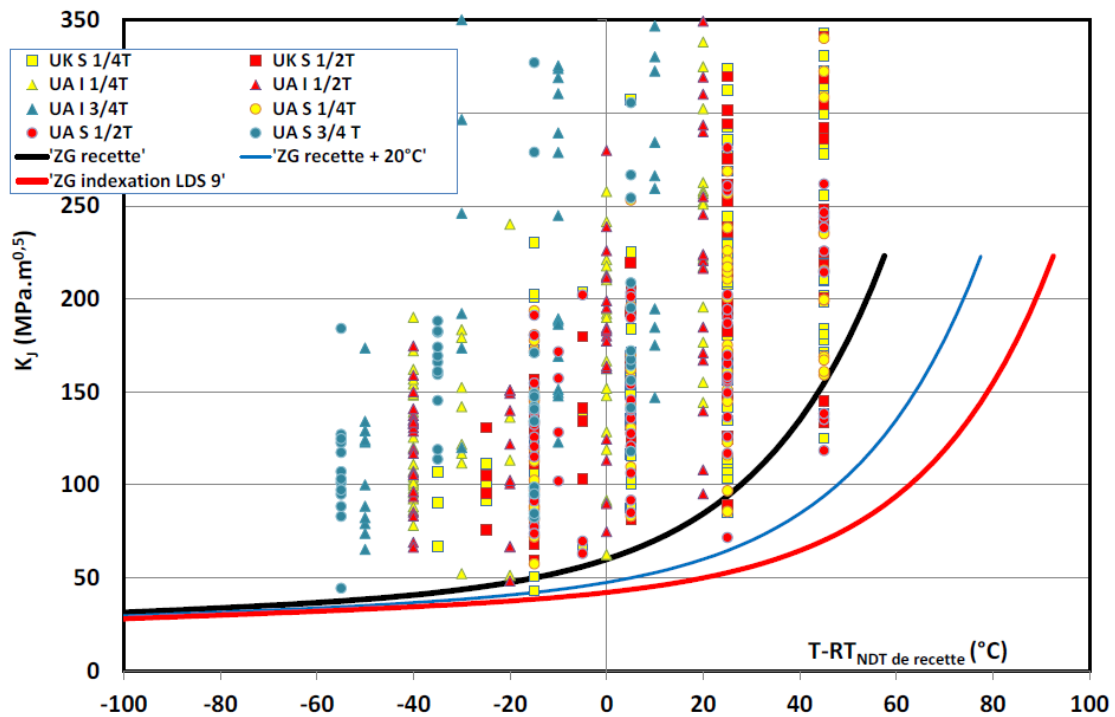

Figure 37: Positioning of fracture toughness data from the test programme in relation to the RCC-M curve [13]

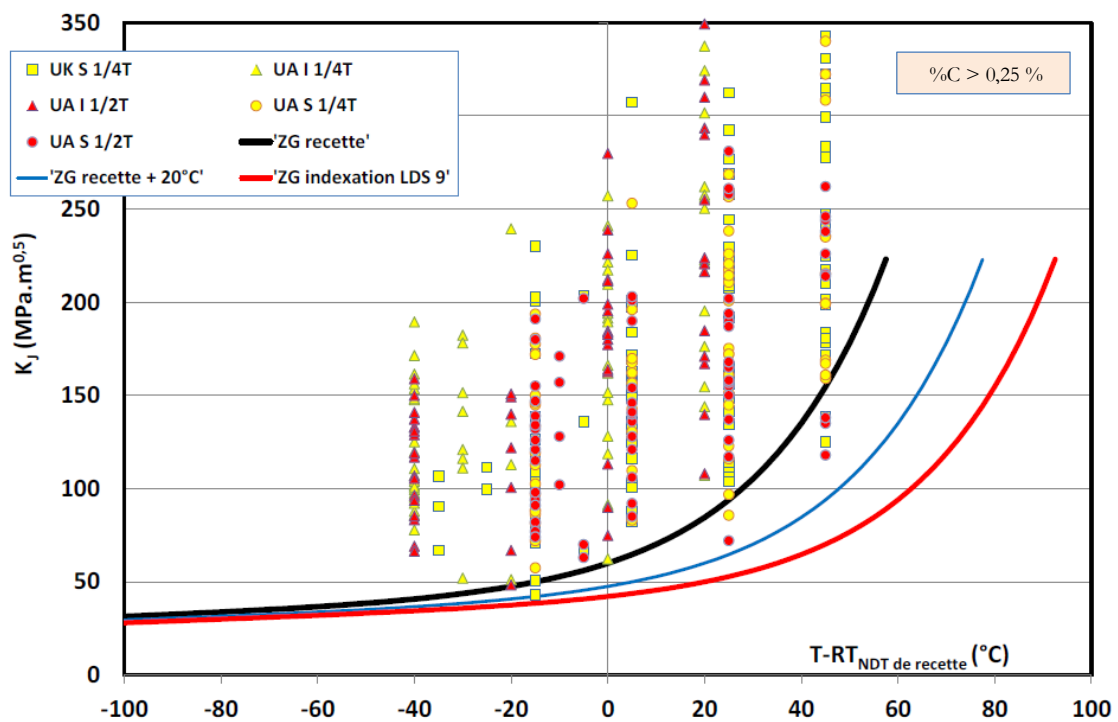

Figure 38: Positioning in relation to the RCC-M curve of the toughness data from specimens with carbon contents greater than or equal to 0.25 % [13]

UK S = UK U, UA I = UA L, UA S = UA U,
 recette = acceptance
 indexation = indexing
 $T - RT_{NDT}$ de recette = acceptance $T - RT_{NDT}$

Areva NP determined the optimum index temperatures of the RCC-M curve to cover the toughness data specific to each sampling zone at one-quarter thickness, mid-thickness and three-quarters thickness, for which the average carbon content is given in Table 35 [13]. These temperatures are given in Table 36 for each zone assessed on each of the scale-one replica domes. The maximum difference between the optimum index temperature and the acceptance RT_{NDT} is obtained at one-quarter thickness of the UK upper dome. It is 18°C (Table 36), a value covered by the 20°C previously mentioned.

| Zone | UK upper | | UA lower | | | UA upper | | |
|---|----------|-----|----------|-----|-----|----------|-----|--------------------|
| | ¼ T | ½ T | ¼ T | ½ T | ¾ T | ¼ T | ½ T | ¾ T |
| Optimum indexing T_{env} (°C) in segregation zone | -27 | -39 | -32 | -31 | -63 | -30 | -21 | -62 |
| Acceptance RT_{NDT} (°C) | -45 | | -30 | | | -35 | | |
| $T_{CV} - 33$ (°C) | -13 | -28 | -28 | -28 | -53 | -3 | -3 | -33 |
| RT_{NDT} (°C) in segregation zone | 0 | -5 | -5 | 0 | -10 | 5 | 5 | -10 ^(*) |

^(*) Interpolated value (see Figure 31)

Table 36: Optimum index temperature of the RCC-M curve

4.3.6. Fracture toughness in the ductile zone

The toughness tests in the ductile domain were carried out and analysed in accordance with standard ASTM E1820 of 2013.

For Areva NP, the test results show that, whatever the sampling zone within the segregation zone and therefore regardless of the carbon content, the ductile tearing resistance ($J_{0.2}$) of the segregation zone at 50°C and 330°C is higher than the minimum values specified by the RCC-M code (Table 37). The minimum values at 50°C and 330°C are obtained at mid-thickness of the UA upper dome. They are of 281 kJ/m² at 50°C and 269 kJ/m² at 330°C, as opposed to 265 kJ/m² and 190 kJ/m² for the minimum values specified by the RCC-M code at 50°C and 330°C respectively. This complies with request n° 3 in the ASN letter in reference [7].

| Dome | UK upper | | UA lower | | | UA upper | | | RCC-M codified value |
|--|----------|-----|----------|-----|-----|----------|------------|-----|----------------------|
| | ¼ T | ½ T | ¼ T | ½ T | ¾ T | ¼ T | ½ T | ¾ T | |
| $J_{0.2mm}$ at 50 °C (kJ/m ²) | 495 | 573 | 593 | 615 | 651 | 417 | 281 | 622 | ≥265 |
| $J_{0.2mm}$ at 330 °C (kJ/m ²) | 325 | 399 | 336 | 447 | 467 | 277 | 269 | 388 | ≥190 |

Table 37: Fracture toughness in the ductile domain measured in the segregation zone of the scale-one replica domes

The chemical analyses performed on the CT25 toughness specimens broken in the ductile domain show that the carbon content of these specimens is primarily between 0.255% and 0.275% with the distribution presented in Figure 39.

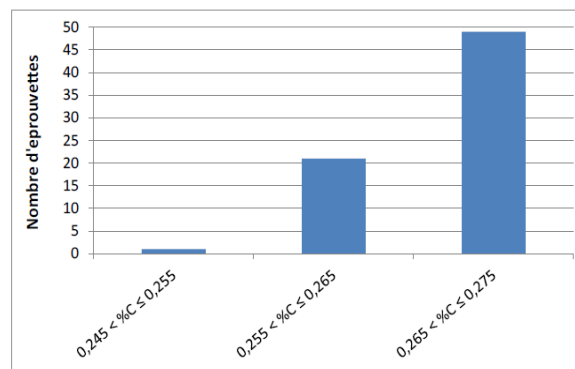

Figure 39: Carbon content of toughness specimens tested in the ductile domain

Number of specimens

4.3.7. Fracture mechanisms

4.3.7.1. *In the brittle-ductile transition domain*

Areva NP had an examination carried out by different laboratories of the fracture surfaces of 108 impact and toughness specimens sampled at one-quarter, mid-thickness and three-quarters thickness of the UK and UA scale-one replica domes [37]. The specimens were selected by Areva NP on the basis of the toughness level reached by the specimen. In the transition domain, the specimens with the lowest toughness values were selected, along with a batch of samples with an average or high toughness in relation to the values obtained at the temperature tested [13] [37].

Areva NP observes that on the whole, the assessments carried out show that the fracture surface of the toughness specimens tested in the brittle-ductile transition domain is typical of a cleavage fracture. On a few specimens with low toughness, the isolated presence of intergranular fracture facets was observed, although without being necessarily associated with the fracture initiation zone. The presence of inclusions, such as manganese sulphides or aluminates, was also reported. However, these inclusions are not clearly identified as being fracture initiation sites.

Areva NP also notes that in the batch of specimens assessed, the fracture surface of a toughness sample taken at one-quarter thickness of the UK upper dome and tested at -80°C comprises a particularity at the fracture initiation site. The fatigue pre-cracking zone presents a large-scale intergranular fracture zone, which Areva NP identifies as being probably the cause of the initiation of cleavage fracture.

4.3.7.2. *In the ductile domain*

The fracture surfaces of the CT2 toughness specimens examined all show the same characteristics: a ductile tearing initiation zone and then a cleavage fracture zone as identified in Figure 40. The presence of manganese sulphide was also observed.



Figure 40: Fracture surface typical of a CT25 specimen tested at 50°C and 330°C

| | |
|----------------------------------|-------------------|
| Assumed fracture initiation zone | Pre-cracking zone |
| | Ductile fracture |
| | Brittle fracture |

4.3.8. Position of the rapporteur concerning the mechanical properties in the segregation zone

4.3.8.1. *Sufficiency of the knowledge provided by the test programme*

The rapporteur underlines the scale of the test programme run by Areva NP to characterise the behaviour of the material in the positive macrosegregation zones. A total of 1722 mechanical tests were carried out: 145 tensile tests, 96 drop-weight tests, 574 Charpy impact tests, 907 toughness tests, including 800 to characterise the brittle-ductile transition domain.

These tests were supplemented by 1503 chemical analyses on broken test specimens taken at different depths in the segregation zone of the scale-one replica domes, in order to examine the extent of the segregation zones in the thickness of the domes. The broken specimens were also subjected to fractography to determine the fracture mechanisms in the heavily segregated zone.

For the rapporteur, this programme comprises a volume of tests comparable to that of the large multipartite international research programmes carried out since 1970 to characterise the behaviour of the ferritic steels used in the manufacture of reactor pressure vessels. With this programme, Areva NP also went beyond what is commonly done to qualify a new manufacturing procedure.

The rapporteur also notes that the number of fracture toughness tests performed covers the statistical distribution domain for toughness, expected in theory for a ferritic steel, and that the toughness data do not significantly deviate from the theoretical distribution. The number of toughness tests performed would therefore appear to be sufficient to evaluate the fracture behaviour of a steel with a higher than expected carbon content.

The rapporteur considers that the knowledge acquired through this test programme is sufficient to assess the properties of the material in the segregation zone and study the mechanical strength of the Flamanville EPR reactor pressure vessel domes at the temperatures to which they will be

subjected in the normal and abnormal conditions and to which they could potentially be subjected in accident conditions. More specifically, the variation in the mechanical properties within the positive segregation zones was determined taking account of the variation in the chemical composition and quenching rate in these zones. Minimum mechanical properties for the segregation zones of the Flamanville EPR reactor pressure vessel domes can be determined on the basis of the tensile properties, the RT_{NDT} measured in the acceptance zone of these domes and the evolution of the material properties with the carbon content.

Finally, this test programme was able to verify that the fracture mechanisms in a heavily segregated zone do not differ from those expected for a ferritic steel. The rapporteur also observes that the presence of a residual carbon segregation is indeed the origin of the change in the mechanical properties.

The Areva NP database, consisting of the results of the scale-one replica programme, was made available to the rapporteur so that it could make its own independent interpretation of the test results. No significant deviation was identified between the analysis by Areva NP and the analysis by the rapporteur of the test programme results.

4.3.8.2. Impact of the carbon content on the mechanical properties of the material

The rapporteur notes that in general, the yield strength and ultimate tensile strength, the different transition temperatures (RT_{NDT} , T_{68j} , T_{CV}) and the reference temperature T_0 change in a similar way: all these parameters increase with the carbon content. This confirms that a rise in the carbon content induces a hardening of the steel, which leads to a lowering of the shock resistance (or impact strength) and flaw initiation resistance (or toughness) by comparison with the acceptance zone. This lowering of the fracture mechanics parameters is more marked in the brittle-ductile transition domain than in the ductile domain.

The yield and ultimate tensile strengths in the segregation zones are higher than those measured in the acceptance zone. The values measured in the acceptance zone constitute the minimum values and are greater than the minimum values specified by the RCC-M code to be considered in the mechanical analyses. The fracture elongation at 20°C is relatively insensitive to the carbon content and remains greater than or equal to the value mentioned by the ESPN order in reference [3] which is 20%. This is thus considered to be satisfactory.

The rapporteur considers that as the tensile properties ($R_{p0.2}$ and R_m) are higher than those of acceptance, the conclusions of the design file are not compromised in the segregation zone, with regard to the plastic instability, excessive deformation and progressive deformation risks.

The T_{NDT} is higher in the segregation zone than in the acceptance zone and appears to be higher than the maximum design value adopted of -20°C. The detection of this difference constitutes the Areva NP reply to request n° 9³² in the ASN letter in reference [7]. In accordance with this request, Areva NP also provided explanations on the observed difference in T_{NDT} . These

³² Request n° 9: “ASN asks you to ensure that the approach is able to assess:

- the conservative nature of curve ZG6110 in the RCC-M indexed on the end-of-life RT_{NDT} selected at the design, minus the shift linked to thermal and stress ageing, as well as the maximum difference between the acceptance RT_{NDT} of the Flamanville 3 domes and that of each of the two scale-one replica domes with regard to the toughness values measured;
- the consistency of the local T_{NDT} with the design value adopted.”

explanations tend to demonstrate that the increase in T_{NDT} is partly linked to the nature of the drop-weight test: a dynamic test with imposed deformation. According to Areva NP, the increase in the yield strength in the segregated zone leads to greater loading on the flaw and also increases the energy to be dissipated at propagation of the flaw. Moreover, the hardening of the material is amplified by the deformation rate. The rapporteur gives no opinion on the arguments put forward on this subject, as the substantiation presented during the examination is in fact absent from the Areva NP file.

These explanations do not however make it possible to ascribe the variation in T_{NDT} observed experimentally between the acceptance zone and the segregation zone solely to this hardening effect, nor to stipulate in what proportion it contributes to it.

In this respect, the rapporteur underlines that, from the viewpoint of the behaviour of the material, the increase in the nil ductility transition temperature, T_{NDT} , between the measurement in the segregation zone and that in the acceptance zone, is consistent with the embrittlement of the material marked by the increase in the other transition temperatures, T_{68j} , T_{CV} and T_0 .

The rapporteur observes that in the acceptance zone and in the segregation zone, the RT_{NDT} is equal to the T_{NDT} . The RT_{NDT} transition temperature and the shift in this temperature resulting from the rise in carbon content (ΔRT_{NDT}) within the same segregated dome, varies little between quarter-thickness and mid-thickness (Figure 31 and Figure 32).

4.3.8.3. Improvement in quenchability linked to the carbon content and quenching effect

On the basis of the test programme results, the rapporteur observes the conflicting effect of the carbon content and the quenching rate on the mechanical properties of the steel and the improvement in quenchability for high carbon contents.

The rapporteur more specifically notes that for the UA upper and lower domes, the transition temperature T_{68j} and the reference temperature T_0 change significantly from three-quarters thickness to mid-thickness, but do not change significantly between mid-thickness and one-quarter thickness, despite a rising carbon content in the scale-one replica domes (Figure 28, Figure 35), in a manner comparable to the T_{NDT} (Figure 31). For the reference temperature T_0 , the change does not exceed 5°C, equivalent to the uncertainty on this parameter. The findings are identical for the ΔT_{68j} and ΔT_0 (Figure 29 and Figure 35).

The interpretation of the fracture toughness results made by the rapporteur reaches the same conclusion. At an identical quenching rate, the reference temperature T_0 increases significantly for carbon contents of between 0.18% and 0.25%. The slope of the curve is then inverted for carbon concentrations of 0.25% or higher and the value of T_0 flattens out, reflecting the improved quenchability at carbon contents of between 0.25% and 0.28% (Figure 41).

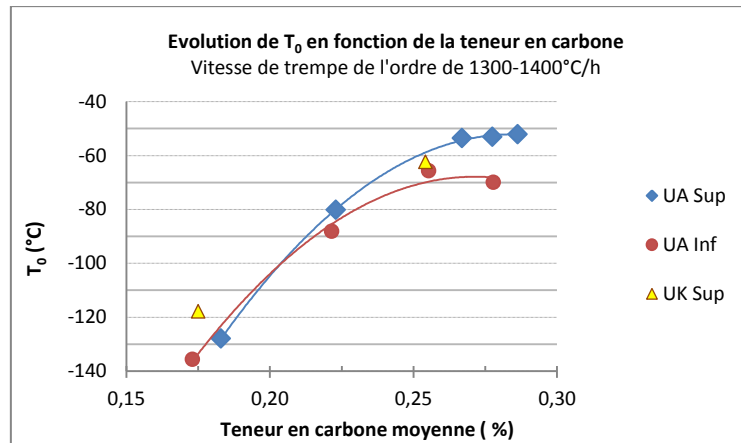

Figure 41: Evolution of reference temperature T_0 versus the carbon content taken from the rapporteur's analysis of the test programme toughness results

Evolution of T_0 versus the carbon content
 Quenching rate about 1300-1400°C/h
 Average carbon content (%)

Therefore, the improved quenchability due to the increase in the carbon content offsets the embrittlement due to a higher carbon content. This is to be taken into consideration when analysing the impact on toughness of a carbon content, which can be between 0.28% and 0.32%, including uncertainties, between one-quarter thickness and the outer surface, a zone which is better quenched.

Finally, the rapporteur also observes that the quenching rate at mid-thickness of a lower dome is higher than that for an upper dome. Thus, the toughness of the material at mid-thickness of a lower dome is appreciably higher than that at mid-thickness of an upper dome.

4.3.8.4. Fracture mechanism in segregation zone

On examining the fracture surface of the toughness specimens, the rapporteur considers that the fracture mechanisms in the segregation zone are on the whole those to be expected for a ferritic steel: cleavage fracture in the brittle-ductile transition domain and initiation of fracture by ductile tearing in the ductile domain. The isolated and marginal presence of intergranular rupture facets was also reported on several specimens examined.

Among the specimens examined, specimen CT1UST310 is however particular. The fatigue pre-cracking zone on this specimen shows a significant zone of intergranular fracture, most probably the origin of the initiation of cleavage fracture. No explanation has been given on the origin of this fracture zone.

The rapporteur considers that Areva NP must carry out the necessary investigations to determine the origin of the intergranular fracture observed on specimen CT1UST310. The rapporteur however notes that the toughness of this specimen is 50% greater than the minimum value determined on the RCC-M curve indexed on the acceptance RT_{NDT} .

In order to more precisely characterise the composition of the zone with these intergranular surfaces, as well as the fracture mode, Areva NP undertook to perform [80]:

- observations of the surfaces of specimen CT1UST310 using a scanning electron microscope;

- microprobe analyses to chemically characterise the zone containing intergranular surfaces.

Areva NP undertakes to provide the results of this examination at the end of September 2017. The rapporteur considers this undertaking to be satisfactory. It will also enable Areva NP to incorporate the results obtained in its pressure vessel commissioning authorisation application.

4.3.8.5. Conservatism of the ZG6110 toughness curve in the RCC-M code when defining minimum toughness in the segregation zone

In accordance with requests n° 9³² and n° 10³³ of the ASN letter in reference [7], the rapporteur notes that Areva NP determined:

- the temperature defined as the design end-of-life RT_{NDT} , minus the shift linked to thermal ageing and stress ageing, combined with the maximum difference between the acceptance RT_{NDT} for the domes of the Flamanville EPR reactor pressure vessel and that of each of the three scale-one replica domes. This latter is equal to the acceptance RT_{NDT} plus 35°C;
- the index temperature of the RCC-M curve optimally encompassing the toughness measurements in the segregation zone;
- the T_{NDT} in the segregation zone;
- the temperatures resulting from the Charpy impact tests in the segregation zone: T_{68J} and $T_{CV} -33°C$.

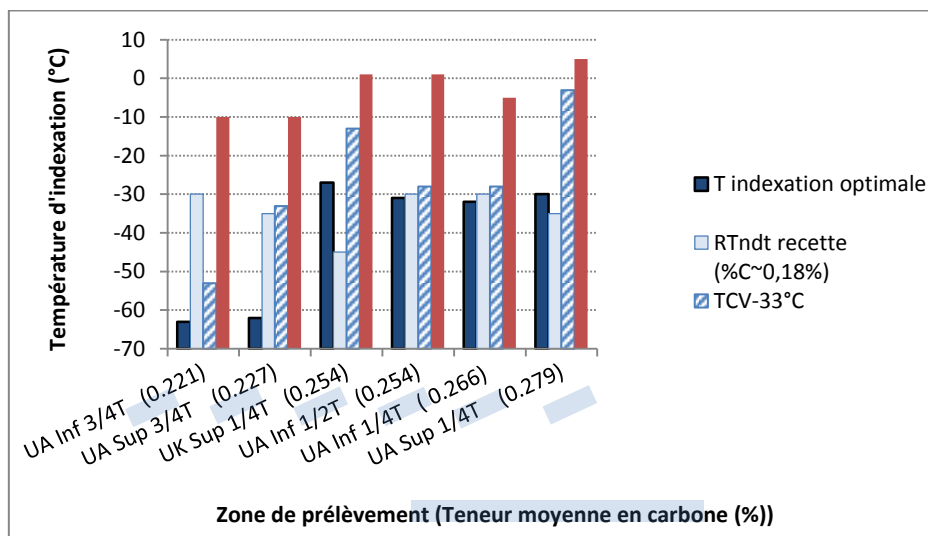

Figure 42: Comparison of the various index temperatures of the RCC-M curve examined in the light of the average carbon content measured on specimen³⁴, at comparable quenching rate (~1300-1400°C/h)

³³ Request n° 10: “ASN asks you to determine:

- the index temperature encompassing the toughness measurements in the segregation zone;
- the index temperature resulting from the drop-weight tests in the segregation zone;
- the index temperature resulting from the Charpy impact tests in the segregation zone, if the local RT_{NDT} is not equal to the local T_{NDT} .

ASN asks you, if necessary, to provide data to help with interpreting the difference between the local T_{NDT} and the local RT_{NDT} .”

³⁴ Figure 42 presents a graphic comparison of the index temperature values obtained locally at one-quarter, mid-thickness and three-quarters thickness (Y axis) versus the carbon contents (X axis) and the corresponding quench rate.

Index temperature
T optimum indexing
Acceptance RT_{ndt}
..
Local RT_{ndt} = T_{ndt}
Sampling zone (average carbon content (%))

The rapporteur observes that the optimum index temperature of the RCC-M curve is below the temperatures T_{CV-33} and T_{NDT} whatever the depth of the dome at which the samples are taken, as shown in Figure 42. This complies with request n°11³⁵ in the ASN letter in reference [7].

The rapporteur observes that the RCC-M curve indexed on the acceptance RT_{NDT} does not constitute a lower bound of all the toughness data from the tests on the specimens taken from the segregation zone associated with quench rates of less than 1500°C/h. The positioning with respect to this curve of 614 toughness data from the tests on samples taken from the segregation zone show thirteen data below the curve, including seven from tests on specimens sampled at mid-thickness. A 20°C increase in the acceptance RT_{NDT} is necessary to cover all of the data. The optimum index temperature of the RCC-M curve, with regard to the segregation zone, is thus equal to the acceptance RT_{NDT} plus 20°C.

Finally, the rapporteur underlines the fact that the indexing of the RCC-M curve on the RT_{NDT} in the segregation zone, equal to the T_{NDT} , enables the conservatism associated with the RCC-M curve to be preserved, with the shift in RT_{NDT} being between 20°C and 45°C inclusive (Figure 32).

The rapporteur considers that the RCC-M curve indexed on the optimum temperature or the RT_{NDT} in the segregation zone is able to cover the toughness data of a zone with carbon contents capable of reaching 0.32% on the surface, owing to the more favourable quench effect between one-quarter thickness and the outer surface (Figure 41).

4.3.8.6. *Fracture toughness in the ductile domain in the segregation zone*

The rapporteur observes that the ductile upper shelf is lower in the segregation zone by comparison with the acceptance zone. However, the rapporteur notes that the ductile tearing resistance at 50°C and 330°C remains higher than the values specified by the RCC-M, which is satisfactory and replies to request n° 3³⁶ in the ASN letter in reference [7].

4.3.9. Transposition of the results obtained on the scale-one replica domes to the domes of the Flamanville 3 EPR reactor pressure vessel

4.3.9.1. *NP Areva file*

Areva NP proposed estimating the toughness of each of the upper and lower domes of the Flamanville EPR reactor pressure vessel from the RCC-M toughness curve indexed on the end-

³⁵ Request n° 11: “ASN asks you to verify that the index temperature encompassing the toughness measurements in the segregation zone is lower than the two other index temperatures mentioned in request n° 10.”

³⁶ Request n° 3: “ASN asks you, through the test results, to demonstrate that in the ductile domain the material has sufficiently ductile and tough behaviour compatible with the design rules used.”

of-life temperatures, defined from the results of the test programme on the scale-one replica domes, that is:

- a temperature encompassing the toughness tests, referred to as T_{env} , transposed to the FA3 domes and increased by 15°C to take account of in-service ageing phenomena;
- an RT_{NDT} defined from the maximum RT_{NDT} measured, transposed to the Flamanville domes and increased by 15°C to take account of in-service ageing phenomena.

The transposition of the scale-one replica domes test results to the Flamanville EPR reactor pressure vessel domes consists in covering a possible difference in behaviour in the segregation zone between these domes by the maximum difference between the RT_{NDT} in the scale-one replica domes acceptance zone and the RT_{NDT} in the acceptance zone of one or other of the Flamanville domes, or +15°C for the upper dome and +25°C for the lower dome. For Areva NP, the transposition factor defined in this way is penalising [11]. For example, on the outer surface of the FA3 upper dome, this leads to the following formulas:

$$T_{env}(FA3 \text{ Upper})_{\text{end of life}} = \max_{UK \text{ Upr}, UA \text{ Lwr}, UA \text{ Upr}} (T_{env}) + \text{transposition factor} + \text{ageing effect}$$

$$= -21 + 15 + 15 = 9 \text{ } ^\circ\text{C}$$

$$RT_{NDT} (FA3 \text{ Upper})_{\text{end of life}} = \max_{UK \text{ Upr}, UA \text{ Lwr}, UA \text{ Upr}} (RT_{NDT}) + \text{transposition factor} + \text{ageing effect}$$

$$= 5 + 15 + 15 = 35 \text{ } ^\circ\text{C}$$

Table 38 and Table 39 detail the calculation of the index temperature of the RCC-M curve to be used in the fracture risk assessments, for the upper dome and lower dome respectively of the Flamanville EPR reactor pressure vessel [11]

| | | Maximum index temperature from the test programme | | Transposition factor | Thermal and stress ageing | Index temperature in the RCC-M curve adopted by Areva NP |
|----------------|---------------|---|------------|----------------------|---------------------------|--|
| FA3 upper dome | Outer surface | T_{env} | -21 °C | 15 °C | 15 °C | 9 °C |
| | | RT_{NDT} | 5 °C | 15 °C | 15 °C | 35 °C |
| | Inner surface | T_{env} | -62 °C (*) | 15 °C | 15 °C | <-5 °C (**) |
| | | RT_{NDT} | -10 °C | 15 °C | 15 °C | 20 °C |

(*) maximum value at 3/4 thickness of UA upper and lower domes

(**) value lower than the design end-of-life value by -5°C (obtained by adopting an initial design RT_{NDT} of -20°C)

Table 38: Upper dome – Index temperature of the RCC-M curve to be used for fast fracture risk assessment

| | | Maximum index temperature from the test programme | | Transposition factor | Thermal and stress ageing | Index temperature in the RCC-M curve adopted by Areva NP |
|----------------|---------------|---|------------|----------------------|---------------------------|--|
| FA3 lower dome | Outer surface | T_{env} | -21 °C | 25 °C | 15 °C | 19 °C |
| | | RT_{NDT} | 5 °C | 25 °C | 15 °C | 45 °C |
| | Inner surface | T_{env} | -62 °C (*) | 25 °C | 15 °C | <-5 °C (**) |
| | | RT_{NDT} | -10 °C | 25 °C | 15 °C | 30 °C |

(*) maximum value at 3/4 thickness of UA upper and lower domes

(**) value lower than the design end-of-life value by -5°C (obtained by adopting an initial design RT_{NDT} of -20°C)

Table 39: Lower dome – Index temperature of the RCC-M curve to be used for fast fracture risk assessment

4.3.9.2. Position of the rapporteur

With regard to the definition of the index temperature of the RCC-M curve, the rapporteur notes that Areva NP chooses a factor for transposition of the scale-one replica domes test results to the Flamanville domes. This factor is defined as being the maximum difference between the acceptance RT_{NDT} of the scale-one replica domes and those of the Flamanville domes. It is +15°C for the upper dome and +25°C for the lower dome.

In the light of the test programme results, the rapporteur considers that an index temperature for the RCC-M curve established assuming the acceptance RT_{NDT} for each Flamanville dome plus the maximum shift observed in the segregation zone with respect to the acceptance RT_{NDT} of the UA and UK domes, and the shift due to the ageing phenomena, is a pertinent means of defining a minimum toughness that is consistent with the conventionally used approach for taking account of hardening embrittlement.

The traditional decision to index the RCC-M curve on the acceptance RT_{NDT} was because of the aim of obtaining a single curve for a whole range of ferritic steel grades, intrinsically integrating the difference in behaviour between parts, through indexing on the acceptance RT_{NDT} . In other words, the acceptance RT_{NDT} constitutes the transposition parameter. The transposition of one dome to another is thus guaranteed if the index temperature is defined from the acceptance RT_{NDT} or from the difference with respect to this acceptance RT_{NDT} . For example, for the Flamanville upper dome, this leads to the following index temperatures.

On the outer surface

$$\begin{aligned}
 T_{env} \text{ (FA3 Upper)}_{\text{end of life}} &= RT_{NDT} \text{ acceptance (FA3 Upr)} \\
 &+ \max_{UK \text{ Upr}, UA \text{ Lwr}, UA \text{ Upr}} (T_{env} RT_{NDT} \text{ acceptance}) + \text{ageing effect} \\
 &= -30 + 20 + 15 = 5 \text{ } ^\circ\text{C} \\
 RT_{NDT} \text{ (FA3 Upper)}_{\text{end of life}} &= RT_{NDT} \text{ acceptance (FA3 Upper)} \\
 &+ \max_{UK \text{ Upr}, UA \text{ Lwr}, UA \text{ Upr}} (RT_{NDT,ZS} - RT_{NDT} \text{ acceptance}) + \text{ageing effect} \\
 &= -30 + 45 + 15 = 30 \text{ } ^\circ\text{C}
 \end{aligned}$$

On the inner surface

$$\begin{aligned}
 RT_{NDT} \text{ (FA3 Upper)}_{\text{end of life}} &= RT_{NDT} \text{ acceptance (FA3 Upper)} \\
 &+ \max_{UK \text{ Upr}, UA \text{ Lwr}, UA \text{ Upr}} (RT_{NDT,ZS} - RT_{NDT} \text{ acceptance}) + \text{ageing effect} \\
 &= -30 + 15 = -15 \text{ } ^\circ\text{C}
 \end{aligned}$$

The rapporteur finally observes that the index temperatures chosen by Areva NP are penalising by comparison with those defined in the rapporteur's approach.

To conclude, the rapporteur considers that the test programme was able to verify that the fracture mechanisms in a heavily segregated zone do not differ from those expected for a ferritic steel. The presence of segregation leads to an increase in the transition temperature.

As the failure of the reactor pressure vessel is not postulated in the installations safety analysis report, the rapporteur considers that it was necessary for Areva NP to assess the properties of the material of the Flamanville EPR reactor pressure vessel domes on the basis of the results of its test programme, using a proven approach whose conservative

nature is absolutely guaranteed. Consequently, the fact that Areva NP adopted a transition temperature rise between the brittle fracture mode and the ductile mode equal to the maximum shift in the nil ductility reference temperature (RT_{NDT}) between the segregation zone and the tested domes acceptance zone is satisfactory.

5. Thermomechanical loadings

The pressure, temperature and flow conditions in the primary system vary according to the reactor operating modes. These operating modes can be steady-state or transient or result from unexpected events affecting the installation. They constitute situations concerning the reactor and thus the primary system. These situations are characterised by thermohydraulic conditions (temperature, flow, pressure) of the reactor coolant which vary as a function of time and which lead to thermomechanical loadings on the structures, including the pressure vessel domes.

The diagram in Appendix 3 gives a concise presentation of the primary system and the systems that can be connected to it, as well as the water inlets and outlets to and from the primary system, which can create thermohydraulic transients.

The conservative nature – both in terms of exhaustiveness and description - of the thermohydraulic transients chosen for defining the thermomechanical loadings used as input data for the assessment of the mechanical strength of the domes, more specifically the fast fracture risk assessment, requires particular attention. This chapter thus deals with the selection of the situations³⁷ which most severely load the lower (vessel bottom head) and upper (vessel closure head) domes and their thermohydraulic descriptions (evolution of temperature, pressure and flow versus time) called characterisations.

The most severe situations for the risk of flaw initiation are those which lead to them opening. These situations are those associated with the hot thermal shock cases for flaws on the outer surface of the domes and with cold thermal shock cases for potential flaws situated on the inner surface (see Figure 43).

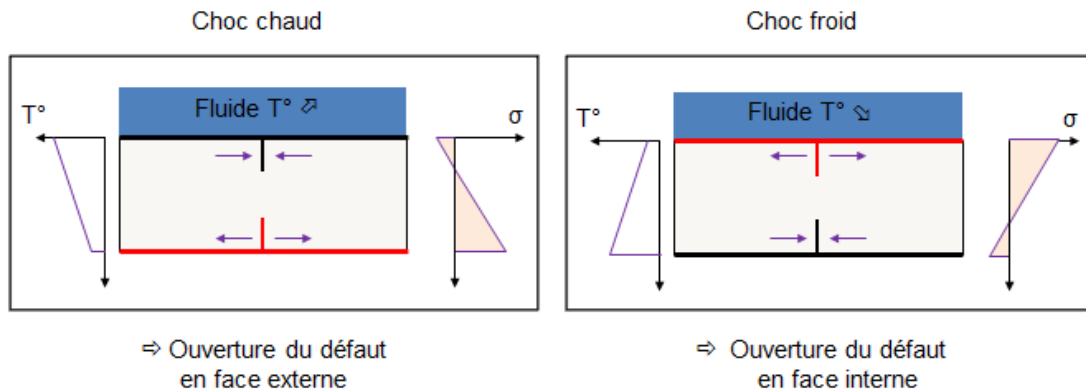

Figure 43: Effect of a thermal shock and pressure on a flaw perpendicular to the surface

| | |
|----------------------------------|----------------------------------|
| Hot shock | Cold shock |
| Fluid | Fluid |
| Opening of flaw on outer surface | Opening of flaw on inner surface |

³⁷ The inventories of design transients (DDS) identify all the normal, upset, incident and accident situations that can affect the main primary system and thus the pressure vessel. They give the thermomechanical loadings to be considered to substantiate the mechanical sizing of the reactor components. The situations are classified by category according to their probability of occurrence. There are four situation categories: the 1st corresponds to the permanent operation situation, the 2nd covers normal and upset operation, the 3rd covers exceptional situations and the 4th covers highly improbable accident situations.

5.1. Pertinent thermohydraulic parameters

A situation is defined by an initiating event and the resulting thermohydraulic transient. This transient is characterised by pressure, fluid temperature and flow values, which vary over time and generate loading of the structures:

- the pressure change creates mechanical stresses in the equipment;
- the changes in fluid temperature create heterogeneous temperature fields in the structures (in other words temperature gradients), which themselves create additional stresses as a result of differential thermal expansion;
- the heat exchange coefficient between the fluid and the structure, which depends primarily on the fluid flow rate, determines the level of the heat flux applied to the structure as a function of the temperature difference between fluid and wall.

A conservative characterisation of the thermohydraulic transient generating loads on the structure is thus defined by maximised variations in the temperature of the fluid (maximised amplitude of the thermal shock) as well as by a maximised pressure and exchange coefficient.

For the risk of fracture in the brittle-ductile transition domain, the most penalising case is generally speaking that for which the initial temperature (for hot shocks) or final temperature (for cold shocks) is as low as possible. The lower the temperature, the lower the toughness of the material.

5.2. Hot shock situations

Areva NP transmitted the note in reference [47] in July to demonstrate the absence of the risk of fast fracture for potential surface-breaking flaws on the outer surface of the domes. During the examination, Areva NP subsequently transmitted the summary note in reference [43] in December 2016, for which several assumptions were considered by the rapporteur as being unable to cover the full variation range of the thermohydraulic parameters with regard to the situations selected by Areva NP. This note was thus revised in reference [44]. This latter presents the selection approach for the most severe hot shock situations and the thermohydraulic description of the situations finally selected.

5.2.1. Identification of selected hot shock situations

The identification of the hot shock transients is based on the conventional list in the inventory of design transients (DDS) for the main primary system (CPP [MCS]) (document in reference [45] for category 2 and in reference [46] for categories 3 and 4). The list of situations taken from the inventory of design transients was supplemented by additional situations leading to hot shock transients that are penalising for the potential flaws on the outer surface of the domes. The approach to search for these additional situations developed by Areva NP encompasses three phases:

- phase 1: identification of physical phenomena leading to pressure vessel cooling;
- phase 2: identification of physical phenomena leading to heating of the pressure vessel heating through hot fluid injection;
- phase 3: identification of corresponding plausible scenarios (cooling followed by heating of the pressure vessel) in order to select the most penalising situations for subsequent study.

Depending on the initial status of the reactor, two possibilities were identified for the occurrence of a hot shock:

- the first concerns all the situations for which the temperature of the domes is initially high before undergoing a cold shock and then a hot shock in succession. The aim is then to identify the heat sinks which could rapidly make contact with the domes and then identify the heat sources. These situations are initiated in state A³⁸ or B³⁹ (initial state on power removal by steam generators);
- the second concerns all the situations initiated in cold state (state C⁴⁰ on power removal by the residual heat removal system RIS-RA⁴¹) and for which the domes undergo a hot shock without prior cold shock⁴².

This approach is applied separately to the lower dome and the upper dome of the pressure vessel. For certain initiating events, the loadings may differ between the domes, or may only affect one of the domes.

Following the application of this approach, Areva NP identified three additional situations with respect to the inventory of design transients in categories 3 and 4:

- for the lower dome, the connection of the residual heat removal system (RIS-RA in RA mode) following a small break LOCA initiated in state A or B, a situation which is classified in category 3;
- for the lower dome, the resumption of natural circulation (RCN) following a small break LOCA initiated in state A or B, a situation which is classified in category 3;
- for the lower and upper domes, the loss of coolant by the RIS-RA residual heat removal system in RA reactor shutdown mode, initiated in state C, a situation which is classified in category 4.

5.2.2. Characterisation of hot shock situations

The characterisation of hot shock situations taken from the inventory of design transients in references [45] and [46] takes account into:

- perfect heat exchange between the fluid and the wall (infinite exchange coefficient) for all the situations;
- lowest primary loop cold leg temperature for the lower dome;
- hot leg temperature, fluid temperature or temperature of the steam in the upper head (volume under the reactor pressure vessel closure head) according to the situation being studied (with or without formation of steam under the upper dome and with or without reflooding) for the upper dome.

For the upper dome, the most severe transients occur during category 2 situation 20A345b in the inventory of design transients (unscheduled fluctuations between hot shutdown and cold shutdown) and, for the lower dome, during the category 3 situation 3.6.1a (small steam line break with total loss of off-site electrical power).

Characterisation of the hot shock transients in addition to the inventory of design transients is covered by Appendix 5.

³⁸ Reactor at power, at hot shutdown and at intermediate shutdown on steam generators ($P_{\text{primary}} > 130$ bar)

³⁹ Intermediate shutdown on steam generators ($P_{\text{primary}} < 130$ bar and $T_{\text{primary}} > 110$ °C)

⁴⁰ Intermediate shutdown on the RIS-RA system in RA mode and normal cold shutdown. The primary system is closed or partially open ($1 \text{ bar} < P_{\text{primary}} < 32$ bar and $15 \text{ °C} < T_{\text{primary}} < 120$ °C)

⁴¹ Safety injection and residual heat removal system

⁴² In state C on RIS-RA, the maximum pressure in the hot leg is 32 bar, the primary system remains pressurisable and the primary temperature is below 120°C.

Hot shock transients selected

The worst-case situations per category, derived both from the inventory of design transients and from the additional transients research, for the postulated outer wall flaws on the domes, are summarised in Table 40.

| | Category | Situation | Description | Reference |
|------------|----------|-------------------------------|---|----------------|
| Upper dome | 2 | DDS 20A345b | Unscheduled fluctuations between hot shutdown (AAC) and cold shutdown (AAF) – Low load 20A case 3-4-5 | [43] [44] |
| | 3 | DDS 3.6.1.a | Small steam line break (RTV [SLB]) without total loss of off-site electrical power | [43] [44] |
| | 4 | Non-DDS Loss RRA [RHRS] | Total loss of cooling by the RIS-RA in RA mode in state C3 reactor coolant pumps stopped | [43] [44] [47] |
| Lower dome | 2 | DDS 20E-1P | Unscheduled fluctuations between AAC and AAF – Large amplitude 20-1 P | [43] [44] |
| | 3 | Non-DDS RCN cat3 | Resumption of natural circulation following small break LOCA | [43] [44] [47] |
| | | Non-DDS RRA [RHRS] connection | Connection of RIS-RA in RA mode following a small break (SB) LOCA | [43] [44] [47] |
| | 4 | Non-DDS RCN cat4 | Resumption of natural circulation following small break LOCA without taking account of mixing with SI | [43] [44] |

Table 40: NP Areva file: Hot shock transients in the inventory of design transients and additional transients to the design transients inventory

5.3. Cold shock situations

In the notes in references [49] and [51], Areva NP presents the cold shock situations selected for the stability analyses of potential flaws at three-quarters thickness, starting from the outer surface, or surface-breaking flaws on the inner surface of the lower and upper domes of the Flamanville EPR reactor pressure vessel. Since for the same loading, since the potential flaws on the inner surface are subjected to larger stresses than any equivalent buried flaws, only the case of flaws on the inner surface is presented below.

Following the technical examination, Areva NP revised its file concerning cold shocks, which finally consists in the note in reference [67].

5.3.1. Identification of cold shock situations

The situations considered by Areva NP are taken from the design transients inventories, except for the control rod ejection situation, which was added during the hot shock technical examination.

5.3.2. Characterisation of cold shock situations

The characterisation of cold shock situations takes into account an infinite heat transfer coefficient for the upper dome in all operating situations, as well as for the lower dome in all situations, except for those indicated in the note in reference [50], which notably include situations resulting from primary system breaks (known as loss of coolant accidents - LOCA).

For these situations, the heat transfer coefficient is calculated as a function of the fluid thermohydraulic conditions, according to the formulations recalled in reference [43].

The temperature application rules are as follows:

- for the lower dome, the cold leg fluid temperature is applied to the inner wall in all situations;
- for the upper dome, the fluid temperature applied is:
 - the hot leg temperature for all category 2 and hydrotest situations;
 - the hot leg temperature for the category 3 and 4 non-bubble forming⁴³ situations, except in the case of rod ejection, where the liquid temperature is that at the outlet from the upper control rod guide tube assemblies;
 - the liquid temperature in the upper head for category 3 and 4 situations without bubble formation, the steam temperature in the upper head for category 3 or 4 bubble formation situations without reflooding;
 - the steam temperature in the upper head until the moment of reflooding then the liquid temperature for category 3 and 4 bubble formation situations with reflooding.

The worst-case situations (excluding test situations) for the surface-breaking flaw selected for the inner surface, are recalled in Table 41 below.

| | Category | Situation | Description | Reference |
|------------|----------|------------|---|-----------|
| Upper dome | 2 | 20A345b | Unscheduled fluctuations between AAC and AAF – low range | [50] |
| | 3 | DDS 3.4.a | Rupture of a steam generator tube | [50] |
| | 4 | Non-DDS | Rod ejection – Break of 45 cm ² | [50] |
| Lower dome | 2 | DDS 20E–3P | Unscheduled fluctuations between AAC and AAF Single-phase cold overpressure case | [50] |
| | 3 | DDS 3.8.2 | Single-phase cold overpressure following unscheduled safety injection | [50] |
| | 4 | DDS 4.9.2 | Single-phase cold overpressure following unscheduled safety injection with one minimal high flow line of SI pump closed | [50] |

Table 41: Areva NP File - Hot shock transients in the inventory of design transients and additional transients to the inventory of design transients

The worst-case situations are single-phase cold overpressure following unscheduled safety injection in category 3 for the lower dome and rod ejection (45 cm² break) in category 4 for the upper dome.

⁴³ A situation is said to be “bubble forming” when the thermohydraulic conditions in the volume under the pressure vessel closure head are such that thermal stratification takes place and a steam bubble can potentially form there.

5.4. Position of the rapporteur

After checking the exhaustiveness of the situations studied by Areva NP to identify which are the most penalising, the rapporteur analysed the conservatism of the characterisation (evolution of the temperature, pressure and flow versus time) of these situations. This analysis was carried out for the pressure vessel upper and lower domes, considering in turn the hot shock and cold shock situations.

The rapporteur underlines the fact that following the in-depth examination of this file and the numerous exchanges which took place during the examination, Areva NP transmitted elements enabling it to complete its initial file and consolidate its demonstration.

5.4.1. Common questions for hot shock and cold shock situations

The characterisation of certain situations raised questions common to hot shock and cold shock situations. This concerns on one hand the evaluation of the heat transfer coefficients between fluid and wall when this coefficient is not assumed to be infinite and, on the other, the analysis of the need to reinforce the operating rules to limit the amplitude of the thermal shocks for category 2 situations. These two points are detailed in Appendix 4.

With regard to the heat transfer coefficient between fluid and wall, the rapporteur considers that the results of the sensitivity studies supplied by Areva NP at the end of the examination ensure that the heat transfer coefficient is calculated conservatively.

In addition, concerning the category 2 situations, the elements provided during the technical examination indicate that the operating rules are sufficient to limit the amplitude of the shocks associated with these situations. The rapporteur considers that these elements are satisfactory and thus considers that it is acceptable not to make provision for any modification to the normal operating rules for the Flamanville EPR reactor.

However, insofar as these rules are able to limit the amplitude of the cold and hot shock transients on the pressure vessel domes during normal and abnormal operation (category 2 situations), the rapporteur considers that the corresponding criteria must appear in the operating technical specifications (STE) of the general operating rules (RGE).

5.4.2. Hot shock situations

5.4.2.1. Identification of hot shock situations

With regard to hot shock situations, the rapporteur notes that the category 2 situations are all taken from the inventory of design transients. However, for categories 3 and 4, the situations identified do not come from the inventory of design transients, except for the upper dome in category 3. Areva NP did not identify any hot shock situations to be added to the inventory of category 3 design transients for the upper dome.

The rapporteur considers that, in principle, the approach developed by Areva NP to identify situations leading to hot shock transients on the pressure vessel domes is satisfactory.

5.4.2.2. Pertinence of the characterisation of hot shock situations

With regard to the characterisation of penalising hot shock situations, numerous exchanges summarised in Appendix 5 enabled Areva NP to clarify and, when necessary, to revise the characterisation initially proposed in order to guarantee its conservative nature.

With regard to the transient corresponding to connection of the RIS-RA in RA mode, the characterisation initially proposed by Areva NP in note [43] was not felt to be satisfactory and led to sensitivity studies concerning the impact of the size of the break which initiates this transient. These additional studies highlighted the existence of larger thermomechanical loading when considering a smaller break size. Areva NP thus defined a new temperature profile [44] characterising the hot shock for this situation. The rapporteur analysed this new profile (see Appendix 5) and found it to be acceptable.

With regard to the transient corresponding to the resumption of natural circulation following a LOCA, its characterisation also changed considerably during the examination. The rapporteur's questions mainly concerned the complex and conflicting physical phenomena which govern this transient. A hot shock is in fact liable to occur at the moment of resumption of natural circulation (RCN) which more specifically depends on the size of the break, the pressure and the temperature of the fluid in the primary system and the safety injection flow rates. These different points were examined in-depth by Areva NP, which performed additional calculations to define and justify acceptable conservative temperature and flow rate profiles for characterising this situation [66]. The analysis of these elements is presented in Appendix 5.

The rapporteur considers that the thermomechanical loadings of the hot shock situations as defined at the end of the examination are acceptable.

5.4.3. Cold shock situations

5.4.3.1. Identification of cold shock situations

With regard to cold shock situations, the rapporteur notes that the penalising situations selected by Areva NP are taken from the design transients inventories, except for the control rod ejection situation, which was added during the technical examination. During the examination, Areva NP transmitted elements aimed at confirming the exhaustiveness of the cold shock situations studied, more specifically identification of the physical phenomena leading to rapid cooling of the fluid in the pressure vessel and cold overpressure causes.

The rapporteur considers that the list of worst-case situations thus completed by Areva NP is exhaustive.

The rapporteur also recalls that the exhaustiveness of the list of situations is reassessed on the occasion of the periodic safety reviews of each reactor in operation. In the note in reference [85], EDF thus undertook to verify the exhaustiveness of the list of situations for the domes of the Flamanville EPR reactor pressure vessel on the occasion of the updating of the regulatory reference files. This verification is based on the search for additional transients used for the reactors in operation.

5.4.3.2. Pertinence of the characterisation of cold shock situations

With regard to the thermomechanical loadings induced by cold shock situations, the rapporteur

considered that the characterisation of certain transients needed to be improved.

Situations with malfunction of RIS-RA [SIS-RHRS] in RA reactor shutdown mode

The installation abnormal operating situations (category 2) correspond to malfunctions of control channels or certain systems. Situations are defined in the inventory of design transients to cover all these malfunctions on the basis of the maximum variations in pressure, temperature and flow-rate that could be envisaged according to the design of these control channels and systems.

The rapporteur asked Areva NP to prove that the situations in the inventory of design transients do indeed cover the malfunction of the RIS-RA in RA mode.

In reply, Areva NP specified [56] that the failure of the RIS-RA control channel was analysed in the DDS in category 2 (situations 20E 2C and 20E 3C). The rapporteur found that this transient is covered by unscheduled opening of a main steam relief train (VDA [MSRT])⁴⁴. However, the unscheduled opening of a VDA does not lead to reactor coolant system temperatures of less than 100°C, unlike a malfunction of the RIS-RA in RA mode. The rapporteur concludes that although the unscheduled opening of a valve of the VDA system covers the RIS-RA in RA mode malfunction situation, this can only be in terms of thermal shock amplitude and not in terms of final temperature.

At the end of the examination, Areva NP transmitted [83] a study of the category 2 situation with unscheduled opening of a temperature control valve of an RIS-RA train in RA mode. This study, which takes account of a certain number of conservative assumptions, shows that this situation is covered by other category 2 situations studied elsewhere in the Areva NP file: the single-phase cold overpressure situation and the low-amplitude temperature variation between hot and cold shutdown states.

The rapporteur considers these elements to be satisfactory and has no other comments concerning the category 2 RIS-RA system malfunction situation.

Cold overpressure situations

The cold overpressure situations, while not strictly speaking thermal shocks, subject the domes to low-temperature loadings and are among the transients to be considered for the fast fracture risk assessment.

The comparison between the reactors in operation and the Flamanville EPR reactor shows that the situations considered are linked to restart of a reactor coolant pump (GMPP [MCCP]) for the reactors in operation, whereas for the Flamanville EPR reactor, they are due to unscheduled start-up of the safety injection system. It would not therefore appear to be certain that the cold overpressures situation selected in the Flamanville EPR reactor inventory of design transients actually cover all the conceivable cold overpressure situations. When questioned on this point, Areva NP sought [53] to identify all the factors which could generate an overpressure (contribution of mass and energy in the primary system), taking account of the design differences between the Flamanville EPR reactor and the reactors in operation. Areva NP deduces that the category 2, 3 and 4 overpressure situations selected in the inventory of design transients are indeed the most penalising for the fast fracture risk assessment.

⁴⁴ Situation corresponding to situation 20 1-C initiated either in shutdown state or in state A or state B.

Although the approach is based on satisfactory principles, the rapporteur finds that its implementation was unable to identify the cold overpressure situation following a break on the RIS-RA system connected in RA mode. Furthermore, this approach was unable to identify the cold overpressure situation further to unscheduled opening of a pressuriser valve followed by reclosure. During these transients, the injection of cold water via the safety injection system causes a cold shock on the lower dome. Isolation of the break by the operator in one case and closure of the valve in the other then lead to overpressure. Following this finding, Areva NP supplemented its file with characterisation of these situations, the analysis of which is summarised in Appendix 6. The thermohydraulic characterisations selected are considered by the rapporteur to be satisfactory.

Finally, the rapporteur completed its analysis with that of the characterisation of the worst-case cold shock transients in categories 3 and 4 for the upper and lower domes. Most of the situations in the inventory of design transients do not affect the upper dome insofar as it remains at a temperature higher than that of the ductile upper shelf of the material (that is 100°C). The worst-case transients for the upper dome are LOCA, cold overpressure and rod ejection (EDG) situations. Only the analysis of the LOCA is presented below, with the analysis of the other situations being summarised in Appendix 6.

Category 3 LOCA situation

The appearance of a break in the reactor coolant system causes start-up of safety injection to rapidly make up the flow lost at the break. This system thus injects cold water into the reactor coolant system which, on penetrating the reactor pressure vessel annular downcomer, causes a thermal shock on its wall and more specifically on the lower dome.

For category 3 classified break sizes, the safety injection flow rate is sufficient to completely fill the reactor coolant system, including the vessel upper head, despite the leak from the break. The arrival of cold water can then also cause a cold shock on the upper dome.

The assumptions selected for analysing this situation aim at maximising the cooling rate. The break studied is therefore located on the hot leg, the cold water injection flow by the safety injection system is maximised and the residual power in the core is minimised. The various operator actions are also taken into account.

A single small break LOCA configuration (in terms of position, number of safety injection trains available, residual power, etc.) per break size considered, that is a diameter of 2.5 cm (section 5 cm²) and diameter 5 cm (section 20 cm²), is included in the inventory of design transients. Furthermore, the maximum break size studied in category 3 is 20 cm² (equivalent to two inches) on the EPR reactor, as compared to 45 cm² (equivalent to three inches) for the reactors in operation. Since the cooling rate is not the only thermohydraulic parameter involved in the mechanical loading study, the rapporteur questioned Areva NP as to the adequacy of the case studied and the influence of the size of the break on the thermomechanical loadings.

In this respect, for the lower dome, the rapporteur carried out studies on the sensitivity to the break size up to 45 cm², to hypotheses maximising dewatering (parameter involved in calculating the fluid temperature after the stoppage of natural circulation) and to the actions of the operator. It turns out that some cases are slightly more penalising than the case presented in the inventory of design transients. However, the temperature of the fluid on the wall of the lower dome is

calculated with the CREARE⁴⁵ correlation, which was established to minimise the temperature at the pressure vessel inlet. This choice therefore includes a conservative margin on the temperature of the fluid arriving at the lower dome, taking into account the possible mixing and heating taking place in the pressure vessel downcomer above the lower dome. **The rapporteur therefore considers the characterisation of the small break LOCA to be acceptable for the lower dome.**

With regard to the upper dome, the characterisation of this situation was established on the basis of a calculation carried out with the CATHARE system software, which uses “0D” point models to represent the upper parts of the pressure vessel, in particular the upper head volume upon which the upper dome is positioned. At the moment where the safety injection cold water penetrates through the spray nozzles and the upper control rod guide outlets (see Figure 44) situated in the upper head volume, complex three-dimensional phenomena may occur (more specifically fluid recirculation loops). The rapporteur considers that the point modelling adopted by Areva NP is unable to represent these phenomena. The penalising nature of the fluid temperature calculated in this way in the upper dome is therefore not confirmed.

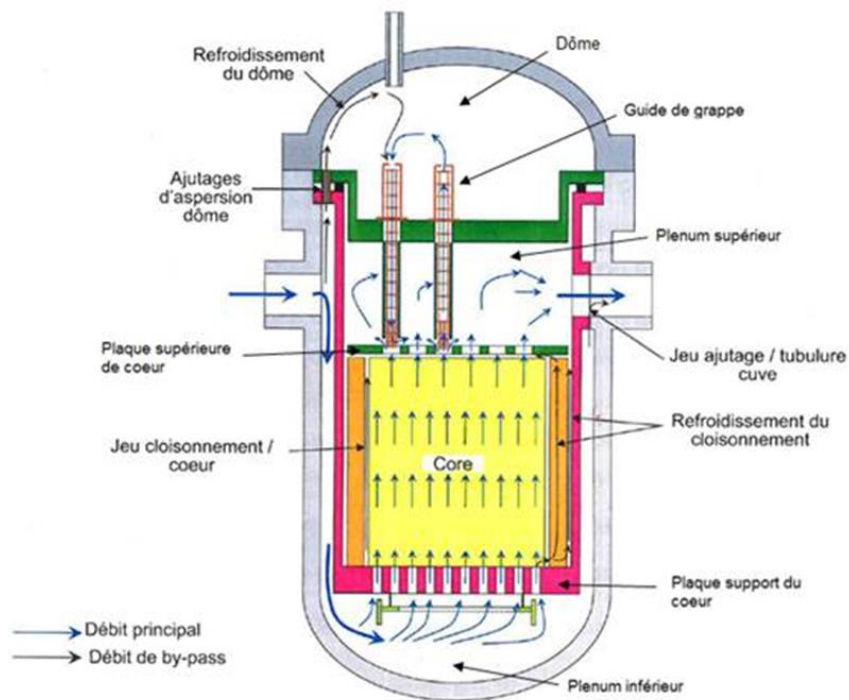

Figure 44: Main flow and core bypass flow in normal operation

| | |
|--------------------------|--------------------------------------|
| Upper head cooling | Upper head |
| | Control rod guide assembly |
| Upper head spray nozzles | Upper plenum |
| Upper core plate | Clearance spray nozzle/vessel nozzle |
| Clearance baffle /core | Core |
| | Baffle cooling |
| | Core baseplate |
| Main flow | |

⁴⁵ The CREARE correlation is used to evaluate a minimum water temperature at the reactor pressure vessel wall if natural circulation is interrupted following partial drainage of the primary system. It is based on the assumption that the fluid temperature at the inner wall of the reactor pressure vessel is that of a volume referred to as a mixing volume, consisting of the volume of primary fluid contained in the cold legs, the annular downcomer and the lower plenum, assuming perfect mixing of the water in this volume with all the injection flows in the primary system evaluated by the CATHARE software. The CREARE correlation was established on the basis of experimental tests of the same name.

On this point, Areva NP considered [65] that the liquid temperature in the upper head volume estimated using CATHARE modelling remains conservative.

Areva NP considers that the arrival of cold water in the upper head leads to gradual condensation of the steam and a slow build-up of subsaturated water in the lower part of the upper head, creating a significant level of stratification: subsaturated liquid at the bottom, layer of saturated liquid at the liquid-steam interface and steam above the interface. When the liquid-steam interface reaches and exceeds the control rod guide assembly outlet, the direct liquid-steam interaction disappears and the exchanges only take place on the layer of saturated liquid at the interface. When the liquid-steam interface reaches the top of the upper dome, the liquid in contact with the inner surface of this dome is saturated. The simplified CATHARE modelling leads to a mixing temperature between that of the cold water and that of the saturated water, which is therefore penalising.

The rapporteur noted the arguments produced by Areva NP but considers that they need to be consolidated with more in-depth analyses. When cold water penetrates the upper head, a sudden condensation phenomenon can occur, with the upper head then being filled with superheated steam. This sudden condensation of the superheated steam can lead to an additional draw-in of cold water into the upper head through the control rod guide assemblies. A transient dynamic phenomena, comparable to a “condensation water hammer”, could lead to rapid reflooding of the upper head volume. The thermal shock on the upper dome would then be faster and larger than the thermal shock resulting from the very gradual condensation of a bubble in contact with a thermally stratified volume of water in the upper head, the surface of which would be at the saturation temperature as presumed by Areva NP. It is important to note that these physical phenomena can appear for all situations causing drainage of the upper head and then its refilling by safety injection.

At the end of the examination, Areva NP transmitted [84] an evaluation of the effect of slow or fast filling of the upper head with safety injection water mainly from the control rod guide assemblies and, to a lesser extent, through the spray nozzles. A condensation coefficient sensitivity study shows that, even assuming fast condensation of the steam, the temperature of the fluid in the upper head remains higher than 100°C during reflooding. Areva NP concludes that the upper dome is not subject to loading in the brittle-ductile transition domain. However, the rapporteur underlines the fact that this calculation still keeps the simplified modelling which is unable to represent the above-mentioned physical phenomena. Areva NP also supplemented this evaluation with a penalising uncoupled approach characterising this transient by a step temperature variation starting from an initial temperature of 320°C down to an extended plateau at low temperature, with the assumption of perfect heat transfer.

The rapporteur considers that the uncoupled temperature evolution selected by Areva NP is satisfactory since it covers the dewatering and rapid filling situations in the upper head volume, following start-up of safety injection in the event of a LOCA.

5.5. Conclusions of the rapporteur

The characterisation of a thermohydraulic transient generating loads on the structure is defined by maximised variations in the temperature as well as by a maximised pressure and heat transfer coefficient. These elements constitute input data for the fast fracture mechanical analyses.

The hot shock and cold shock situations liable to trigger initiation of a potential flaw, located

respectively on the outer surface and inner surface, were examined by Areva NP in order to identify the situations considered to be the most penalising for each category and to define the associated loading. After checking the exhaustiveness of the situations studied by Areva NP to identify the most penalising, the rapporteur analysed the pertinence of the characterisation (evolution of the temperature, pressure and flow versus time) of these situations for each category, in order to ensure that they are conservative. This analysis was carried out for the pressure vessel upper and lower domes, considering the hot shocks and the cold shocks.

The rapporteur underlines the fact that following the in-depth examination of this file and the numerous exchanges which took place during the examination, Areva NP transmitted elements enabling it to complete its initial file and consolidate its demonstration.

The rapporteur therefore considers that the approach developed by Areva NP to identify the situations creating thermal shock transients on the pressure vessel domes is satisfactory. The rapporteur recalls that the exhaustiveness of the list of situations is reassessed on the occasion of the periodic safety reviews of each reactor in operation. EDF thus undertook to verify the exhaustiveness of the list of situations for the domes of the Flamanville EPR reactor pressure vessel on the occasion of the updating of the regulatory reference files.

Finally, the rapporteur considers that the numerous updates made by Areva NP during the examination finally led to thermomechanical loadings resulting from these situations that are judged to be conservative.

6. Analysis of the fast fracture risk

Ferritic steels display purely brittle behaviour at very low temperature ($T-RT_{NDT}$), mainly ductile behaviour at $T-RT_{NDT}$ temperatures above 60°C and mixed behaviour between the two. It must be demonstrated that the risk of fracture of the Flamanville EPR RPV lower head and closure head in the event of the segregated material being subject to loading in these three temperature ranges can be ruled out.

The toughness tests performed for the test programme on the scale-1 replica domes show that the increase in the carbon content does not affect the behaviour of the ferritic steel at very low temperature. The toughness curve indexed on the acceptance test RT_{NDT} and that defined for the areas with a carbon content higher than 0.25% are found to be identical at $T-RT_{NDT}$ temperatures below -100°C (Figure 37). Furthermore, as the lowest temperature that can be applied to the domes in operation is 15°C [70] and the maximum end-of-life RT_{NDT} is 45°C (paragraph 4.3.9.1 and Table 39), loading of the dome steel in its purely brittle behaviour range is unlikely.

The toughness tests performed for the test programme also show that the segregated areas display sufficiently ductile behaviour when hot, with the toughness effectively remaining higher than the minimum values prescribed by the RCC-M code for ferritic steel. The conclusions of the fast fracture design file are not called into question for the corresponding temperature range.

Consequently, to prove the absence of a fast fracture risk it is essentially a question of assessing the risk of fracture in the brittle-ductile transition zone at $T-RT_{NDT}$ temperatures below 60°C . The assessment, carried out by Areva NP, follows the procedure set out below which was approved by ASN after the GP ESPN meeting of 30th September 2015 [7].

6.1. Fast fracture risk assessment procedure

The risk of fast fracture of the domes is assessed with respect to the risk of fracture initiation from a flaw potentially present in the most stressed areas of the domes. This risk is considered to be ruled out if the toughness of the dome steel is sufficient to prevent the initiation of this flaw under all the loads to which the dome in question is subjected, increased by a safety factor (α) which depends on the probability of occurrence of the loading (Table 42). This comes down to verifying that the stress intensity factor (K_{CP}) at the flaw remains lower than the toughness (K_{JC}), whatever the loading, which is written as follows:

$$F_m = K_{JC}/(\alpha.K_{CP}) \geq 1 \quad \text{or} \quad RT_{NDT} \leq RT_{NDT \text{ allowable}}$$

The $RT_{NDT \text{ allowable}}$ is the RT_{NDT} for which the reserve factor F_m equals 1.

| Situations | Classification | Probability of occurrence /year.react | Safety factor α |
|---|----------------|---------------------------------------|------------------------|
| Normal and disrupted | Category 2 | $f > 10^{-2}$ | 2 |
| Incident and hydrostatic pressure tests | Category 3 | $10^{-4} < f < 10^{-2}$ | 1.6 |
| Accident | Category 4 | $10^{-6} < f < 10^{-4}$ | 1.2 |

Table 42: Safety factor from appendix ZG 3230 of the RCC-M code

The minimum toughness of the Flamanville ERP RPV lower and upper domes is estimated from the toughness curve of appendix ZG 6110 of the RCC-M code indexed on the end-of-life temperatures, which are themselves defined from the results of the test programme conducted on the scale-1 replica domes, namely:

- a penalising temperature taken from the toughness tests on the scale-1 replica domes, called T_{em} , which differs depending on whether it concerns the inner or outer surface of the scale-1 replica domes, transposed to the Flamanville ERP RPV domes and increased by 15°C to take account of in-service ageing phenomena (see paragraph 4.1.1.5);
- an RT_{NDT} defined from the maximum RT_{NDT} , which differs depending on whether it concerns the inner or outer surface of the scale-1 replica domes, transposed to the Flamanville ERP RPV domes and increased by 15°C to take account of in-service ageing phenomena (see paragraph 4.1.1.5);

The calculation of these indexing temperatures is presented in detail in paragraph 4.3.

The stress intensity factors were established using the approach recommended in appendix ZG of the RCC-M code.

In a first stage, the pressure stresses and thermal stress in the structure are evaluated, considering elastic behaviour and the absences of flaws. For the Flamanville EPR RPV domes, these stresses were determined from finite element calculations with a three-dimensional model for the upper dome and an axisymmetric two-dimensional model for the lower dome.

In a second stage, knowing the stresses at the postulated flaw, the stress intensity factors (K_{CP}) are calculated from the influencing functions available in charts (RSE-M code or Tada-Paris Handbook [71] or developed specifically by Areva NP [18][68][69]). A correction is then applied to take in account the elasto-plastic behaviour of the structure, in accordance with the recommendations of the RCC-M code.

Lastly, due to the increase in the T_{NDT} in segregated areas, Areva NP analysed the appropriateness of increasing the conservatism of the mechanical analyses for category 4 in accordance with the position expressed by ASN in point 2⁴⁶ of appendix 2 of its letter reference [10]. In Areva NP's opinion, the increase in the T_{NDT} in segregated areas does not solely indicate a deterioration in crack-stopping capacities since this increase is, according to its own interpretations of the tests, partly linked to the hardening of the material. Areva NP therefore considers that the conservatism of the category-4 analyses is sufficient.

6.2. Postulated flaws

In the mechanical analyses, Areva NP postulates the presence of flaws that it considers to be the most harmful in view of the loads present in each dome. For Areva NP, these are flaws perpendicular to the surface of the domes due to the stress field created by the pressure and temperature loadings (see Figure 43). This flaw orientation is therefore adopted for all the flaws postulated in the structure (Figure 45). The size of the flaws was defined consistently with the detection limits of the ultrasonic testing equipment (see part 3): 10 mm x 20 mm.

⁴⁶ ASN position statement: "I consider that depending on the RT_{NDT} values which will be determined in segregated zones, the conservatism of the mechanical analyses for category-4 situation will have to be increased."

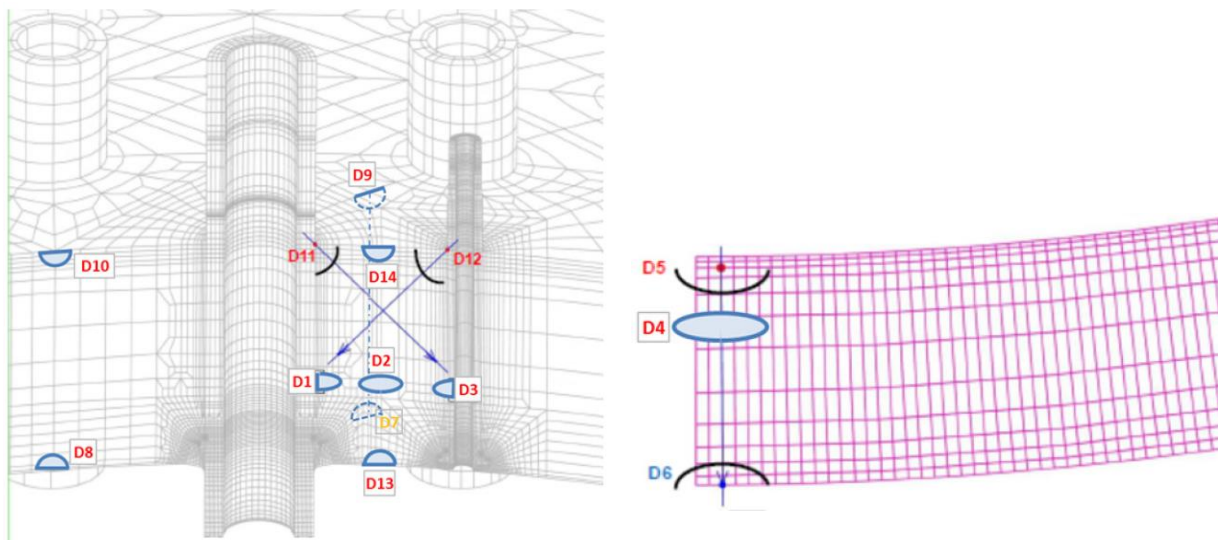

Flaws studied on upper dome

Flaws studied on lower dome

Figure 45: Location of the postulated flaws

6.3. Methods of calculating the stress intensity factor associated with each type of flaw

Table 43 presents the method of calculating the stress intensity K_{CP} associated with each type of flaw postulated in each dome, and more particularly the influencing functions used and the plastic correction applied.

| Type of flaw | Size a x 2c (mm x mm) | Location (flaw) | Determination of the stress intensity factors | |
|---|--------------------------------|---|--|------------------------------|
| | | | Influencing functions | Plastic correction |
| Surface-breaking flaw on outer surface | 10 x 60 | Continuous region (D6, D9, D10, D14) | Appendix 5.4 of RSE-M (surface-breaking flaw in a plate) | Appendix ZG 5110 of RCC-M |
| | 10 x 20 | Corner of bore (D11, D12) | Specific Areva NP development [18] [68][69] | |
| Under-cladding flaw (DSR) | 10 x 60 | Continuous region (D5, D7, D8, D13) | Appendix 5.4 of RSE-M (surface-breaking flaw in a plate) | |
| Flaw embedded at three-quarters thickness | 10 x 60 | Continuous region (D2, D4) | Tada-Paris chart [71] | |
| | 10 x 30 | Corner of bore (D1, D3) | Specific Areva NP development [18][68][69] | |
| Surface-breaking flaw on outer surface | 20 x 120 | Continuous region (D6, D9, D10, D14) | Appendix 5.4 of RSE-M (surface-breaking flaw in a plate) | |
| | 20 x 120 | Corner of bore (D11, D12) | Specific Areva NP development [18][68][69] | |

Table 43: Synthesis of independently studied flaws and method of calculating the associated stress intensity factors

6.4. Restrictive loadings considered

Areva NP has examined the hot shock and cold shock situations that lead to the opening of a localised flaw on the outer surface and inner surface respectively, which has allowed the adoption of a number of situations considered to be the worst-case situations for each situation category (see chapter 5 and Appendix 12). These are drawn from the sensitivity studies whose results are summarised in Appendix 14. Ultimately, the worst-case situation for each category of situations has been identified in order to establish the minimum margins for the fast fracture risk of the Flamanville EPR RPV domes. These situations are listed in Table 44 and Table 45.

The heat exchange between the fluid and the internal wall of the domes during thermal transients is assumed to be perfect (infinite heat transfer coefficient), except for the study of the surface-breaking flaws on the inner surface of the lower dome which is taken as being variable. The thermal and thermomechanical characteristics are taken from the RCC-M code.

| Hot shocks | Category 2 | Category 3 | Category 4 |
|------------|------------|---------------------------------------|---|
| Upper dome | 1A1-90 | Primary system overpressure when cold | Loss of RIS-RA in RA mode |
| | 20A345b | | |
| Lower dome | 20E-3P | Connection of RIS-RA in RA mode | Resumption of natural circulation after loss of coolant accident (LOCA) |
| | 20E-1P | | |

Table 44: Worst-case hot shock transients chosen by Areva NP for the Flamanville EPR RPV domes

| Cold shocks | Category 2 | Category 3 | Category 4 |
|-------------|------------|------------|-----------------------------------|
| Upper dome | 20A345b | 3.4 (a) | Rod ejection 45 cm ² |
| Lower dome | 20E-3P | 3.8-2 | Break on RIS-RA system in RA mode |

Table 45: Worst-case cold shock transients chosen by Areva NP for the Flamanville EPR RPV domes

The hydrostatic pressure tests performed at the end of manufacturing before first commissioning⁴⁷ and for requalification when in service are situations that place loads on potential flaws. That is why Areva NP also examined the risk of fracture initiation during these tests. The test temperatures and pressures are given in Table 46.

⁴⁷ The RPV has already been tested in the factory and will be tested again at the same time as the main primary cooling system before commissioning.

| Hydrostatic pressure test (EH) | |
|--------------------------------|---|
| End of manufacture (EH2) | Periodic requalification (EH3 and subsequent) |
| P=25 MPa T=35°C | P=21 MPa T=60°C |

Table 46: Pressure and temperature of hydrostatic pressure test

6.5. Fracture margins in the brittle-ductile transition zone

6.5.1. 10-mm high flaw

During the end-of-manufacturing hydrostatic pressure test performed at a temperature of 35°C, the risk of a 10-mm flaw initiating fracture would appear to be ruled out according to Areva NP. In effect, the minimum reserve factor is greater than 1 for both the lower and upper dome. The indexing temperatures in segregated areas (T_{env} and RT_{NDT}) therefore remain below the allowable RT_{NDT} , which enables request No.12 of the ASN letter reference [7] to be satisfied (Table 47).

| Transposed start-of-life indexing temperature (*) | T_{env} in segregated area | RT_{NDT} in segregated area | Allowable RT_{NDT} |
|---|------------------------------|-------------------------------|----------------------|
| Upper dome | -6°C ($F_m = 2.2$) | 20°C ($F_m = 1.2$) | 32°C |
| Lower dome | 4°C ($F_m = 1.8$) | 30°C ($F_m = 1.1$) | 36°C |

(*) Indexing temperature established considering the results of the test program ($T_{env} = -21°C$, $RT_{NDT max} = 5°C$) increased by the transposition factor specific to the EA3 upper and lower domes individually, see 4.3.9..

Table 47: Fracture margins in end-of-manufacturing hydrostatic pressure testing situation for an outer surface flaw (the worst-case area) [11][72]

According to Areva NP, throughout reactor operation the risk of fracture initiation starting on a 10 mm flow in the lower dome or the upper dome can also be considered to be ruled out. In effect, the calculations give reserve factors greater than 1 whatever the indexing temperature of the RCC-M curve considered (Table 48, Table 49). Consequently, the allowable RT_{NDT} , all situation categories considered, remains higher than the indexing temperatures of the curve of the RCC-M, in accordance with request No.12 of the ASN letter reference [7] (Table 48, Table 49).

For Areva NP, the risk of fracture during the periodic requalification hydrostatic pressure tests at a temperature of 60°C is also ruled out. The minimum reserve factor is 1.8 for the upper dome and 1.5 for the lower dome. It is defined taking into account the minimum toughness obtained on completion of the test programme (Table 48, Table 49).

Lastly, Areva NP's calculations show that any flaw embedded at three-quarters of the thickness displays higher margins with respect to the fracture initiation risk than an inner surface flaw of the same size under the cladding. These margins are given in Table 48 and Table 49.

| Location of flaw | Transposed end-of-life indexing temperature (see 4.3.9) | | Minimum reserve factors for a 10-mm flaw | | | Hydrostatic pressure test during operation |
|------------------|---|-------------|--|------------|------------|--|
| | | | Category 2 | Category 3 | Category 4 | |
| Outer surface | Design RT_{NDT}^{48} | -5°C | 4.7 | 4.7 | 3.6 | > 3.5 |
| | T_{env} (ZS) ⁴⁹ | 9°C | 3.6 | 3.6 | 2.6 | 3.5 |
| | RT_{NDT} (ZS) ⁵⁰ | 35°C | 2.5 | 2.7 | 1.6 | 1.8 |
| | RT_{NDT} allowable | 74°C | - | - | 1.0 | - |
| Inner surface | Design RT_{NDT}^{48} | -5°C | 3.5 | 4.3 | 4.0 | > 4.6 |
| | T_{env} (ZS) ⁵¹ | < -5°C | > 3.5 | > 4.3 | > 4.0 | > 4.6 |
| | RT_{NDT} (ZS) ⁵² | 20°C | >2.0 | >1.8 | >1.5 | > 2.7 |
| | RT_{NDT} allowable | 49°C | - | - | 1.0 | - |

Table 48: Upper dome - Minimum reserve factors F_m and allowable RT_{NDT} values on outer surface and inner surface [11][72]

| Location of flaw | Transposed end-of-life indexing temperature (see 4.3.9) | | Minimum reserve factors for a 10-mm flaw | | | Hydrostatic pressure test during operation |
|------------------|---|-------------|--|------------|------------|--|
| | | | Category 2 | Category 3 | Category 4 | |
| Outer surface | Design RT_{NDT}^{48} | -5°C | 5.8 | 2.3 | 2.9 | > 3,5 |
| | T_{env} (ZS) ⁴⁹ | 19°C | 3.9 | 1.5 | 1.8 | 2.8 |
| | RT_{NDT} (ZS) ⁵⁰ | 45°C | 3.0 | 1.1 | 1.2 | 1.5 |
| | RT_{NDT} allowable | 60°C | - | 1.0 | - | - |
| Inner surface | Design RT_{NDT}^{48} | -5°C | 4.2 | 3.2 | 3.6 | > 3.2 |
| | T_{env} (ZS) ⁵¹ | <-5°C | > 4.2 | > 3.2 | > 3.6 | > 3.2 |
| | RT_{NDT} (ZS) ⁵² | 30°C | 2.1 | 1.6 | 1.6 | 2.0 |
| | RT_{NDT} allowable | 57°C | - | - | 1.0 | - |

Table 49: Lower dome - Minimum reserve factors F_m and allowable RT_{NDT} values on outer surface and inner surface [11][72]

⁴⁸ RT_{NDT} used in the initial design file (before the anomaly was detected)

⁴⁹ Transposed end-of-life T_{env} on outer skin

= T_{env} (-21°C) + transposition factor (+15°C for upper dome, +25°C for lower dome) + ΔRT_{NDT} ageing (+15°C)

⁵⁰ Transposed end-of-life RT_{NDT} on outer skin

= RT_{NDT} in segregated zones of UK an UA domes (+5°C) + transposition factor (+15°C for the upper dome, +25°C for the lower dome) + ΔRT_{NDT} ageing (+15°C)

⁵¹ Maximum transposed end-of-life T_{env} on inner skin

= Maximum T_{env} at three-quarters thickness of the UA domes (-62°C) + transposition factor (+15°C for upper dome, +25°C for lower dome) + ΔRT_{NDT} ageing (+15°C)

⁵² Maximum transposed end-of-life RT_{NDT} on inner skin

= Maximum RT_{NDT} at three-quarters thickness of the UA domes (-10°C) + transposition factor (+15°C for upper dome, +25°C for lower dome) + ΔRT_{NDT} ageing (+15°C)

6.5.2. Margins for a conventional 20-mm high flaw

As a complement to the analysis of the risk represented by a flaw at the detection limit (10-mm high flaw), Areva NP studied the risk of fracture initiation from a conventional flaw with a height of 20 mm and length of 120 mm located in the outer surface. The aim of the sensitivity-to-flaw-size study is to demonstrate the robustness of the domes to a large flaw. The reserve factors for this flaw are found to be greater than 1 in all the situation categories, including the end-of-manufacturing hydrostatic pressure tests at a temperature of 35°C (Table 50), considering the temperature that covers the toughness values.

| Indexing temperature $T_{env} = 19^{\circ}\text{C}$ | Minimum reserve factors for a 20-mm surface-breaking flaw on outer surface | | | |
|--|--|------------|------------|--|
| | Category 2 | Category 3 | Category 4 | End-of-manufacturing hydrostatic pressure test |
| Upper dome | 1.9 | 2.4 | 1.5 | 1.3 |
| Lower dome | 2.4 | 1.1 | 1.3 | 1.2 |

Table 50: Fracture margin for a 20-mm flaw on the outer surface of the FA3 RPV domes [11]

6.6. Position of the rapporteur concerning the fast fracture risk analysis

6.6.1. Approach

The rapporteur notes that the fast fracture risk assessment is consistent with the approach prescribed in the RCC-M code, as much through the choice of flaws analysed as through the definition of the minimum toughness and the evaluation of the stress intensity factors.

The rapporteur notes that in response to point 2⁵³ of appendix 2 of the ASN letter reference [10], Areva NP does not consider it necessary to increase the conservatism of the mechanical analyses in category-4 situations.

The rapporteur notes that Areva NP effectively verifies that the fracture reserve factors are greater than 1, by considering the RCC-M curve indexed on the RT_{NDT} effectively measured in a segregated area by means of drop-weight tests (see below). **In view of the satisfactory conservatism of this indexing, the rapporteur considers that it is acceptable not to reinforce the conservatism in category 4.**

6.6.2. Toughness

The rapporteur notes that the estimation of toughness in the segregated area is based on the results of the test programme, and more precisely on the indexing temperatures of the RCC-M curve, defined conservatively. The rapporteur considers this approach satisfactory (see paragraph 4.3.9.2).

⁵³ Request N°2: "Depending on the RT_{NDT} values that will be determined in segregated zones, I ask you to adopt a position on the need to increase the conservatism of the mechanical analyses considered in the currently proposed file, in order to cover the uncertainties."

6.6.3. Method of calculating the stress intensity factor

The rapporteur has no particular reservations with regard to the use of the influencing functions defined in the RSE-M code or the plastic correction applied for the study of a surface-breaking flaw on the outer surface and in the continuous regions of the Flamanville EPR RPV upper and lower domes.

For the study of the flaws situated in the corner of bores and on the outer surface of the upper dome, the rapporteur notes that Areva NP has developed specific influencing functions which have been validated internally by Areva NP and published in a peer-reviewed international scientific review. In the rapporteur's opinion, the development method for these influencing functions is consistent with the conventional approach and requires no comments.

The rapporteur does nevertheless note that the methods mentioned above were not developed specifically for the study of under-cladding flaws and that for certain loadings they may be less penalising than the method dedicated to the study of under-cladding flaws which is also available in the RSE-M code. This is primarily related to the plasticity correction applied, which differs from that prescribed in the RCC-M code.

The rapporteur asked Areva NP to evaluate the reserve factors for the under-cladding flaws with the method specific to the study of such flaws codified in the RSE-M code. Areva NP carried out this evaluation for the worst-case transients; the results do not call into question the established conclusions [86] and the rapporteur has no particular comments to make in this respect.

6.6.4. Flaw size

The rapporteur notes that no flaw representing a crack that is not in conformity with the technical specifications has been detected in the Flamanville EPR RPV upper or lower domes during the manufacturing inspections (see chapter 3). The flaw considered in the mechanical analyses is a hypothetical flaw, larger in size than the largest flaw detectable by ultrasonic inspection. The rapporteur considers that the size and orientation of the flaws postulated individually are conservative. For a same given flaw size, any flaw that is not perpendicular to the surface is less penalising than a perpendicular flaw due to the mode of loading. As flaws lying parallel or virtually parallel to the surface are not heavily loaded, tolerance to such flaws is better. The rapporteur has no particular comments to make regarding the size and direction of the flaws postulated in the fast fracture analyses with respect to the conclusions of the non-destructive test performance analysis presented in chapter 3 of this report.

6.6.5. Loadings adopted

With regard to the thermal shock situations creating stresses in a hypothetical flaw in the inner or outer surface of the domes, the rapporteur notes firstly that the most penalisation situations have effectively been adopted in the mechanical analyses for each situation category, and secondly that the pressure and temperature transients induced by these situations were defined conservatively (see chapter 5).

Furthermore, at the request of the rapporteur, Areva NP has provided proof in the notice reference [73] that the loads exerted by contact between the adaptor tube and the closure head introduce negligible stresses compared with those induced by the pressure and temperature transients. The rapporteur has no particular comments concerning the justification.

6.6.6. Fracture margins

The rapporteur notes that, according to Areva NP's calculations, the toughness in the segregated area is sufficient to ensure the mechanical resistance of the upper and lower domes of the Flamanville ERP reactor pressure vessel in all situation categories and during the hydrostatic pressure tests. The margins with respect to the fracture risk are reduced with respect to those calculated with the properties of a non-segregated material, but remain greater than 1. The RT_{NDT} in segregated areas and even more so the optimum indexing temperature in segregated areas are lower than the allowable RT_{NDT} , which satisfies request No. 12⁵⁴ of the position statement letter reference [7].

The rapporteur carried out its own analyses to verify Areva NP's calculations.

The rapporteur considers that the risk of fracture initiated from a flaw in the Flamanville EPR RPV domes can be considered to be ruled out in view of the margins determined by Areva NP.

⁵⁴ Request No. 12 of ASN letter reference [7]: "*ASN requests that you verify that the indexing temperatures determined by the test programme are lower than the maximum permissible indexing temperature that results from the fracture mechanics analyses.*"

7. Impact of the irregularities detected within the Areva NP Creusot Forge plant in the handling of the anomaly in the Flamanville EPR RPV domes

7.1. Detection of deviations

The detection of several technical anomalies in the Areva NP Creusot Forge plant since 2012, including those affecting the Flamanville EPR RPV domes, led ASN in April 2015 to ask Areva NP and EDF to analyse all these events and draw the lessons that can be learned from them.

ASN more particularly urged Areva NP to start a quality review of the parts manufactured in the past by its Creusot Forge plant which produced the two Flamanville EPR RPV domes and the three scale-1 replica domes. This review, conducted by an independent third-party organisation which only went back as far 2010 and turned out to be relatively superficial, was considered insufficient by ASN because it did not allow an overall judgement of the organisation and practices at Creusot Forge plant or of the quality of the parts produced and the safety culture prevailing within the plant.

Areva NP therefore initiated new review actions in early 2016 which led to the detection of irregularities in internal documents of the Creusot Forge plant marked with a sign, usually a double slash. Some of the information contained in these "barred" files reveals deviations from applicable requirements or inconsistencies with the content of the end-of-manufacturing files presented to the customer and the safety authorities.

Investigations carried out as from summer 2016 on files not marked with a specific sign revealed further deviations which had not been communicated to the customer or the safety authorities either. Areva NP then decided to carry out an exhaustive review of all the available documentation for all the parts manufactured in the past by Creusot Forge.

Areva NP set up a dedicated organisation to carry out this exhaustive review. An inspection unit is tasked with re-reading and examining all the documents in the archives relating to the parts produced. These archives comprise end-of-manufacturing reports and internal documents (forging records, ingot orders placed with steel mills, originals of test reports, heat treatment curves, etc.). The documents are re-read on the basis of a guide which specifies more than one hundred points to examine, such as:

- verification of compliance with the regulations and manufacturing code applicable at the time of production of the components;
- verification of the correct transcription of values between the reports in the internal files and the end-of-manufacturing report;
- looking for inconsistencies in the results presented in the various documents;
- looking for any additional operations not recorded in the end-of-manufacturing report.

Following this review, the inspection unit draws up a findings report as soon as an element is found suspect, then a technical unit coordinated by Areva NP engineering characterises the findings which are subsequently examined by a technical committee made up of Areva NP and EDF experts. Depending on the conclusions of this review, the findings are either classified as compliant or deviation sheets (for deviations from the Creusot Forge internal requirements) or anomaly sheets (for deviations with respect to the regulations, the RCC-M code or customer requirements) are drawn up. Lastly, the various sheets are processed by the quality unit and then transmitted to ASN.

It is important to note that the anomaly in the carbon composition of the steel of the Flamanville EPR RPV domes is not the consequence of a concealed deviation but of a poor technical assessment.

7.2. Deviations detected

The review of the files resulting in Areva NP detecting four deviations that concern the two Flamanville EPR RPV domes and the three scale-1 replica domes covered by this report:

- the measurement of the hydrogen content during the pouring of the Flamanville lower dome was defective;
- the reagent used for the metallographic analyses was not suitable for measuring the size of the primary austenite grains on the five domes;
- a "barred" file containing a mechanical tests report presenting bending rupture energy values at -20°C (52 J, 96 J, 32 J with the comment "unofficial results") is present in the Creusot Forge archives for Flamanville EPR RPV upper dome. These values differ from those indicated in the end-of-manufacturing report summary (102 J, 96 J, 92 J). Nevertheless, the individual values in the "barred" file comply with the requirements specified in the RCC-M code (minimum individual value of 28 J, minimum mean value of 40 J) ;
- in some cases the Creusot Forge plant carried out a preheating treatment when applying the weld beads to the test specimens for the drop-weight tests, which could affect the T_{NDT} values.

Areva NP examined each of these deviations and concluded that they have no impact on the conformity or the representativeness of the parts.

In 2015, Areva NP also detected deviations in the performance of tensile tests in the acceptance test areas. At the request of the rapporteur, Areva NP repeated:

- the tests concerned performed on the Flamanville EPR RPV domes;
- tests at room temperature and at 350°C for each of the three scale-1 replica domes.

Performance of these tests was monitored by a third-party organisation mandated by ASN.

The results of these repeat tests are in conformity with the criteria of the RCC-M code. Areva NP concludes from this that the deviations in the tensile tests have no impact on the conformity or the representativeness of the parts. The end-of-manufacturing reports shall be updated with the new values.

7.3. Position of the rapporteur

ASN ascertained, by analysing the methodological guides drawn up by Areva NP, that the manufacturing file review method is appropriate, that is to say that it enables retrospective guarantees to be obtained regarding compliance with the requirements applicable when each of the parts was manufactured. ASN also verified through inspections that this method is effectively applied.

ASN carried out one particular inspection with the aim of examining the conditions of Areva NP's review of the manufacturing files of the two Flamanville EPR RPV domes and of the three scale-1 replica domes, and determining whether these files contain elements that could call into question the foundations on which the file concerned by this report is based. During this inspection, ASN also verified the findings classified as compliant by Areva NP (ASN inspection follow-up letter reference [29]).

Further to these inspections and the analysis of the processing of the findings made during Areva NP's reviews, the rapporteur considers that the method of re-reading the files, as undertaken by Areva NP, is appropriate for the objective of providing guarantees concerning compliance with the requirements applicable when the parts were manufactured.

The rapporteur does however note that the method has a limit which concerns the number of documents the Areva NP inspectors have to examine, and which makes it impossible to have a complete guarantee that nothing will be missed in this re-reading process.

Independently of the examination of the files, starting from the principle that the quality of a part can be verified by inspecting its internal soundness and by verifying its mechanical properties, the rapporteur tried to identify the areas of residual uncertainties.

The rapporteur observes in particular that many mechanical tests were carried out again after 2016 and these repeat tests were monitored by a third-party organisation mandated by ASN. Surface inspections were also carried out after 2016, such as thermographic inspection, ultrasonic inspection to search for flaws under the cladding⁵⁵ and long-duration dye-penetrant inspection of the Flamanville EPR RPV lower head. Lastly, some mechanical tests carried out before 2016 were performed in laboratories outside the Areva NP group. The rapporteur considers that these tests and inspections provide guarantees of the quality of the parts concerned.

Conversely, some tensile tests and the drop-weight tests in the acceptance test areas of the domes were performed before 2016 in the Creusot Forge plant laboratory, sometimes using inappropriate procedures. Furthermore, some of the volumetric inspections by non-destructive testing on the Flamanville EPR RPV domes were carried out before 2016. The rapporteur considers that performing these tests and inspections again would provide further guarantees with regard to the quality of the parts concerned and the absence of deviations that could call into question the representativeness between the domes. It would also consolidate Areva NP's processing of each of the identified deviations.

At the request of the rapporteur, Areva NP repeated:

- the tensile tests in the acceptance test areas of the Flamanville EPR RPV domes, previously performed in 2016 in the Creusot Forge laboratory;
- a test at room temperature and at 350°C for each of the scale-1 replica domes on test specimens having undergone quality and stress relief heat treatments;
- the drop-weight tests in the acceptance test areas of the Flamanville EPR RPV domes and of the three scale-1 replica domes, previously performed in 2016 in the Creusot Forge laboratory;
- the volumetric inspections by non-destructive testing during manufacture on the Flamanville EPR RPV lower head. The same inspection can no longer be performed on the lower head due to the lack of accessibility.

⁵⁵ The ultrasonic inspection to look for flaws under the cladding of the Flamanville EPR RPV closure head was carried out in the Areva NP Saint-Marcel plant and was monitored by an organisation mandated by ASN.

Performance of these tests was monitored by a third-party organisation mandated by ASN.

The results of these repeat tests and inspections are in conformity with the criteria of the RCC-M code. Consequently, the rapporteur considers that they provide additional guarantees with regard to the quality of the parts concerned and the absence of deviations that could call into question the representativeness between the domes.

The rapporteur also notes that the mechanical property values determined during these tests do not call into question its own conclusions regarding the mechanical strength of the domes.

8. In-service inspection

8.1. Areva NP file

8.1.1. Summary of ASN requests

In its opinion in reference [6] drafted following the 30 September 2015 session, the GP ESPN recalled its position on operating measurements and in-service inspection:

“The Advisory committee notes that the demonstration approach proposed by Areva NP is an analysis of the fast fracture mechanical behaviour of the Flamanville 3 reactor pressure vessel bottom head and closure head domes, based on tests carried out on two representative scale-one replica parts. This approach could show that the manufacturing process confers mechanical properties on the material that are sufficient to rule out the feared risks.

However, the Advisory Committee considers that this will be unable to guarantee restoration of the first level of defence in depth that would have been provided by technical qualification in conformity with current standards.

The Advisory Committee therefore considers that, consistently with its opinion of 2011, the file must be accompanied by proposed operating measures or in-service inspections appropriate to the situation encountered and, as necessary, these must be incorporated into the equipment instruction manual. It wishes to examine them in the light of the results of the tests to be performed.”

Further to this opinion, in the letter in reference [7], ASN sent Areva NP the following request: *“ASN asks you to propose reinforced measures for commissioning oversight, operation and in-service inspection appropriate to the situation encountered and to incorporate them into the equipment instruction manual.”*

8.1.2. Position of Areva NP

Areva NP considers that the analysis of the manufacturing conditions, the results of the non-destructive test inspections performed during manufacturing and the results of the additional non-destructive test inspections described in chapter 3 of this report, preclude the presence - at the end of manufacturing - of flaws that are prejudicial in terms of the risk of fast fracture.

Areva NP also considers that:

- the only flaws that can be envisaged at the end of manufacturing are flaws parallel to the surfaces which are not prejudicial in terms of the risk of fast fracture;
- understanding of the material, the loadings and the effect of ageing mean that the in-service creation of flaws cannot be envisaged;
- the loading levels in the segregation zone do not enable the propagation of a possible flaw not detected during manufacturing to be envisaged, even assuming that a flaw perpendicular to the surfaces could exist.

Based on these considerations, Areva NP considers that there is no flaw known to date that could propagate in the segregation zone and that in-service inspection is not necessary. Areva NP does not therefore make any provision for carrying out in-service inspection on the domes of the Flamanville EPR reactor pressure vessel.

However, in order to satisfy the requests of the rapporteur formulated during the review, Areva NP did, in the document in reference [14] examine the feasibility of in-service inspection techniques and the corresponding pre-requisites, without envisaging that the licensee must implement them.

The feasibility study identified the zone to be inspected as the outer part of the domes over a surface area with a diameter of 1600 mm (conservatively including the positive macrosegregation zone) over a depth between the outer surface and one-quarter thickness inclusive.

Areva NP analysed the in-service inspection possibilities for detection of a flaw with a height of 10 mm and a length of 30 mm, taking account, on the one hand, of the performance of the inspection methods utilised during manufacturing, which detect a rough flaw of 10 mm by 20 mm and, on the other, the flaw considered in the fast fracture calculations of 10 mm by 60 mm.

8.1.2.1. *Inspectability of the Flamanville EPR reactor pressure vessel lower dome*

Areva NP examined the possibility of inspection using the tools and procedures available for in-service inspection of the reactor pressure vessel bottom head.

Areva NP considers that these inspections are possible, provided that adaptations are made to the tool dedicated to inspecting the reactor pressure vessel bottom head weld on the in-service inspection machine (MIS) developed by the Intercontrôle company (focused immersion ultrasonics) and transducers on the plate are developed. Areva NP does not however rule out limits on the performance of this inspection (zone covered and flaw size).

The feasibility study carried out by Areva NP concludes that:

- the zone targeted by the MIS for this examination (in assessment mode as defined in the order in reference [2]) would be a volume extending to a depth of 20 mm from the outer wall of the reactor pressure vessel bottom head and on a surface covering the centre of the forging over a diameter of 1600 mm;
- the flaw searched for would be planar, more than 30 mm long and more than 10 mm high, perpendicular to the wall, radially oriented (see Figure 46) surface-breaking on the outer wall or with a maximum ligament of 10 mm, entirely included in the examination zone;
- an examination zone of 36 mm (i.e. up to one-quarter thickness) does not give the same performance and this option implies a significant drop in the detection threshold and the notation of a large number of spurious signals.

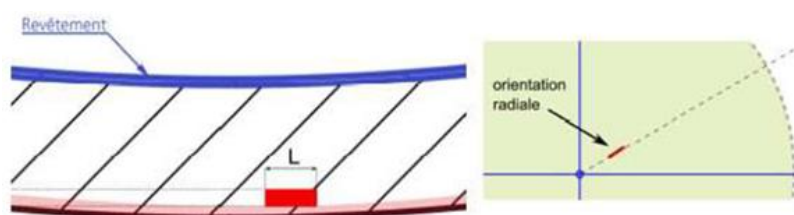

Figure 46: Radially oriented flaw

Cladding
radial orientation

Following the requests for clarification from the rapporteur, Areva NP also indicated that the time needed to develop the MIS is estimated at 3.5 months, excluding the inspection qualification phase.

8.1.2.2. Inspectability of the Flamanville EPR reactor pressure vessel upper dome

For reasons of accessibility of the zone to be inspected, the Areva NP feasibility study opts for a multi-element contact ultrasounds process, from the interior of the closure head.

Areva NP numerically modelled the performance of this examination for the two flaws represented in Figure 47. Based on this simulation, Areva NP estimates that the coverage of the zone to be examined would be:

- about 50% to search for adapter corner flaws radially oriented with respect to the centre of the adapter and oriented in azimuth along the shortest ligament (Figure 47, case A);
- about 85% for flaws on the continuous part oriented along the shortest ligament between adapters and perpendicular to the outer surface (Figure 47 case B).

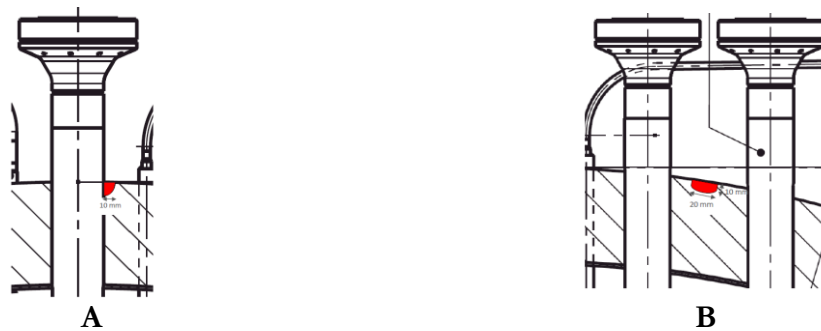

Figure 47: Flaws simulated for the ultrasounds inspection

Areva NP does not specify the performance of these inspections and states that, owing to the geometry and the presence of the adapters, in-service inspection of the entire closure head is not possible.

8.2. Position of the rapporteur

8.2.1. Principle of defence in depth and break preclusion

8.2.1.1. *Principle of defence in depth*

Article 3.1 of the BNI order in reference [4] requires that the licensee design and operate its BNI in accordance with the principle of defence in depth.

The design of nuclear installations must thus lead to the implementation of successive defence levels (intrinsic characteristics, material and organisational provisions, procedures), intended to prevent incidents and accidents and then, if this were to fail, to mitigate their consequences: The design is based primarily on the first four levels of defence in depth⁵⁶:

- the purpose of the *first level of defence* is to prevent incidents: for the equipment, steps are taken to ensure a high standard of quality in their design and manufacture and to provide a high level of guarantee of that quality;
- the aim of the *second level of defence* is to detect the occurrence of such incidents and apply measures that will firstly prevent them from leading to an accident, and

⁵⁶ The fifth and final level concerns the emergency response plans.

secondly restore a situation of normal operation or, failing this, place and maintain the reactor in a safe condition. For items of equipment, this requires verification of their design hypotheses during operation and in particular:

- operating provisions to ensure that the equipment is used in the operating range defined by the design hypothesis,
- maintenance and monitoring provisions to ensure that the equipment remains in a condition compliant with that considered at the time of design;
- the aim of the *third level of defence* is to control any accidents that could not be avoided or, failing this, to prevent them from worsening by regaining control of the installation in order to return it to and maintain it in a safe condition: for the equipment, steps are taken to mitigate the consequences of its failure;
- the aim of the *fourth level of defence* is to manage accident situations resulting from failure of the provisions of the first three levels of defence in depth, in order to mitigate their consequences, especially for persons and the environment. This fourth level allows the management of accident situations involving fuel melt.

These levels of defences must be sufficiently independent for the failure of one level not to call into question the effectiveness of the other levels of defence in depth.

8.2.1.2. Break preclusion

The Flamanville EPR reactor safety case is based on a hypothesis of break preclusion⁵⁷ for the large equipment items on the primary system. This is in particular the case for the pressure vessel domes. No reasonable provision could be defined to mitigate the consequences of their failure as an initiating event.

Precluding the breaking of a component means that its failure is not postulated in the safety case. Thus, nothing is planned under the third level of defence to mitigate the consequences of its failure. Consequently, the break-preclusion hypothesis makes it necessary to reinforce the first two levels of defence in depth in order to achieve a satisfactory level of safety.

This approach must be based on particularly demanding provisions in terms of design, manufacture and in-service inspection, such as to preclude any break. These provisions concern:

- analysis of all damage modes, the use of materials with sufficient ability to withstand these damage modes, determining the loads to which they are subjected, including in the event of a hazard, and verifying compliance with the criteria such as to preclude the break risk;
- the use of manufacturing and inspection processes able to demonstrate that a very high level of quality is obtained, taking account – in accordance with point 4 of the preliminary remarks to appendix I of the directive in reference [1]⁵⁸ – of the “*state of the art in techniques and practices at the time of design and manufacturing, as well as technical and economic considerations compatible with a high level of protection of health and safety*”;
- in-service inspection, more particularly to verify in good time that there is no component deterioration.

⁵⁷ The notion of “break preclusion” used in this report corresponds to that of an “unbreakable component” in the draft ASN and IRSN guide entitled “Recommendations for the design of PWR reactors”.

⁵⁸ The main safety requirements of appendix I to the directive in reference [1] are made applicable by the ESPN order in reference [3].

With this in mind, a conservative definition of the loadings experienced, analysis of the behaviour of the structures under these loadings, the existence of margins, more specifically with respect to the mechanical criteria, the qualification of manufacturing processes, the choice, scope and performance of the inspection techniques in the light of the manufacturing processes, the definition of manufacturing flaw acceptance criteria, the accessibility of the zones to be monitored in-service and the scope of the associated inspections, the integration of experience gained on the behaviour of similar materials or installations are all necessary for implementation of this approach.

As recalled by the standing nuclear section⁵⁹ (SPN) of the central committee for pressure vessels (CCAP), at its meeting of 21 June 2005 devoted to break preclusion on main primary and secondary system pipes for the EPR project, the demonstration of break preclusion *is based on the following elements which are all of the same importance: design, design verification, manufacture, manufacturing inspection, in-service inspection*". At the same session, it stated that *"the verification of the design, the inspection of manufacturing and the in-service inspection must be reinforced so that the appearance of deterioration of the equipment compromising the prevention of the various damage modes and the absence of timely detection of these deteriorations becomes improbable"*.

8.2.2. Consequences on the serviceability of the Flamanville EPR reactor pressure vessel head domes

8.2.2.1. *Analysis of the first level of defence in depth*

Non-compliance with the technical qualification requirement

The rapporteur notes that the technical qualification processes for the manufacturing process carried out by Areva NP in accordance with chapter M140 of the RCC-M code and point 3.2 of appendix I of the ESPN order in reference [3], were unable to manage and control the residual carbon segregation risk. The shortcomings in the analyses performed for these technical qualifications led to the manufacture of a material which does not meet the level of quality normally expected for such a component.

They also led Areva NP to estimate that, during manufacturing, it was not necessary to carry out appropriate measurements and tests on the pressure vessel domes, when it was still possible to perform them, to verify the satisfactory control of the risks of heterogeneity. A satisfactory analysis would probably have resulted in the manufacturer carrying out carbon hardness profiling on the surface and mechanical tests on specimens which could have been sampled when the pressure vessel bores were made, so that the quality of the material could have been assessed directly on the part.

The rapporteur thus observes that the high level of quality is not reached for these components and that the technical qualification process was unable to detect the anomaly at an early stage in manufacturing. A correct system would have enabled the manufacturer to modify its process in order to eliminate the anomaly.

State of the art and current practice at the time of design and manufacture

The rapporteur also notes that the domes of the pressure vessel of another EPR reactor were manufactured at the same time as those of the Flamanville EPR reactor, using a different

⁵⁹ The NPE Advisory Committee replaced the SPN as of 2010.

technique. This technique led to the production of components for which the final state did not comprise the same chemical composition anomaly in the steel.

The rapporteur recalls that Appendix 1 of the directive in reference [1], invoked by the ESPN order in reference [3] requires that account be taken of *“the state of the art and current practice at the time of design and manufacture, as well as technical and economic considerations compatible with a high level of protection of health and safety”*.

The rapporteur observes that Areva NP did not take account of the state of the art and current practice at the time of design and manufacture and did not use the best available technique.

Reduction of fast fracture risk margins

The rapporteur considers that the demonstration of the mechanical strength of the domes for the feared risk of fast fracture shows the existence of margins (see chapter 6). In the light of the results of the test programme, the manufacturing process thus gives the material sufficient mechanical properties to preclude this risk. The rapporteur however underlines that **the mechanical strength analyses presented in chapter 6 of this report show that the presence of a carbon macrosegregation zone significantly reduces the existing margins** by comparison with domes that do not contain the anomaly (see Table 49 and Table 50).

Review of the first level of defence in depth

The rapporteur considers that the shortcomings observed in the technical qualification process, the use of a manufacturing process which was unable to control and manage the residual carbon segregations and the reduction of fast fracture risk margins, mean that the first level of defence in depth is affected. The Areva NP demonstration approach is unable on its own to restore this first level of defence in depth.

Thus, insofar as failure of the reactor pressure vessel domes is not postulated in the Flamanville EPR reactor safety case, the rapporteur considers, following on from its report in reference [5], the opinion of the GP ESPN in reference [6] and the ASN position statement in reference [7], that **the demonstration approach proposed by Areva NP needs to be supplemented by measures to reinforce the second level of defence in depth.**

8.2.2.2. Reinforcement of the second level of defence in depth

In the same way as Areva NP, the rapporteur considers that the manufacturing conditions and the inspection results lead to a reasonable level of confidence with regard to the absence of unacceptable flaws following the manufacturing operations and that, according to the current state of knowledge, no flaw propagation mechanism exists.

Operating experience feedback has shown the benefits of this second level of defence and its independence from the first. The rapporteur thus recalls that during operation of the French NPP reactors, numerous cases of unanticipated flaw initiation and propagation mechanisms have been detected, sometimes shortly after commissioning. This is for example the case with the stress corrosion of the Inconel 600 found on the pressure vessel head adapters, the pressuriser instrumentation nozzles and the reactor pressure vessel bottom head penetrations, the grain-boundary decohesion of dissimilar metal joints and thermal fatigue in mixing zones. In all these cases, the anomalies were detected by in-service inspections or by in-service leak detection, or during requalification hydrotests. These inspections and tests contribute to the second level of defence in depth.

The rapporteur recalls that the Flamanville EPR reactor was designed for an operating life of 60 years and considers that the second level of defence in depth needs to be reinforced, with periodic verification of the absence of prejudicial flaws. The absence of such flaws is a key element in demonstrating the mechanical strength of the pressure vessel domes.

At the request of the rapporteur, Areva NP examined the feasibility of non-destructive test inspections during reactor maintenance outages and, at the end of this examination, EDF made an undertaking, in the notices in references [78] and [81] to carry out the in-service volume inspections described in Table 51, which will eventually be qualified in accordance with the order in reference [2]⁶⁰. Some of the technical inspection solutions, not as yet available, will be the subject of an international call for proposals to industry and universities. These ultrasound inspections are designed to search for flaws perpendicular to the surface with radial and circumferential orientation. For the reactor pressure vessel bottom head, EDF adopted the search for a flaw of 10 mm x 30 mm and, for the reactor pressure vessel closure head, a flaw of 10 mm x 10 mm at the adapter corner and 10 mm x 30 mm in the continuous part.

⁶⁰ Until the processes are qualified, EDF plans to use them for assessment purposes, as defined in the order in reference [2], in other words they will be used by specialists with officially recognised expertise and the conclusions of the assessment report will be approved within a framework such as to guarantee their quality.

| Deadlines | RPV closure head dome | | | RPV lower head dome | | |
|---|--|---|---|--------------------------|--------------------------|---|
| | Outer part (first 20 mm) | Inner part (first 20 mm) | Entire thickness | Outer part (first 20 mm) | Inner part (first 20 mm) | Entire thickness |
| Pre-service inspection (before commissioning) | Non-qualified manual inspection Limited scope ^(a) | Non-qualified manual inspection Coverage ratio to be estimated | - | Non-qualified inspection | - | - |
| First complete requalification (no later than 30 months after first fuel loading) | - | - | - | Qualified inspection | Non-qualified inspection | Non-qualified inspection ^(b) |
| First complete requalification + 2 years | Non-qualified automated inspection Limited scope ^(a) | Non-qualified automated inspection | - | - | Process qualification | Process qualification ^(b) |
| At each 10-yearly outage | Qualified inspection Limited scope ^(a) | Qualified inspection ^(b) | Qualified inspection ^{(b) (c)} | Qualified inspection | Qualified inspection | Qualified inspection ^(b) |

(a) Inspected zone limited to the shortest ligament between adapters:
50% at nozzle corner; 80% in continuous part (Figure 49, Figure 50)

(b) Prior technical feasibility study required

(c) International call for proposals envisaged by EDF in the absence of an existing technical solution

Table 51: EDF commitments regarding in-serviced inspection by non-destructive volume tests [78] [81]

EDF undertakes to analyse the conclusions of the technical feasibility studies for new processes and for the qualification of the process to inspect the outer first 20 millimetres of the closure head, at the end of 2025. If the conclusions were to prove negative, EDF undertakes to replace the closure head on the occasion of the first ten-yearly outage inspection.

Reactor pressure vessel bottom head

With regard to the pressure vessel bottom head, the rapporteur considers that the EDF undertakings presented in Table 51 focus primarily on detecting the most prejudicial flaws, which is satisfactory.

The rapporteur questioned EDF on its ability to detect a flaw that is slightly disoriented with respect to the radial and circumferential directions. At this stage, EDF considers that in the outer part, given the ultrasound path, only flaws disoriented by less than 3° would be detectable (see Figure 48). The rapporteur thus notes that the inspections proposed by EDF will only be able to detect flaws oriented along two angular beams of 6°, or less than 7% of the possible orientations of flaws perpendicular to the outer surface, which would not constitute a significant reinforcement in the second level of defence in depth.

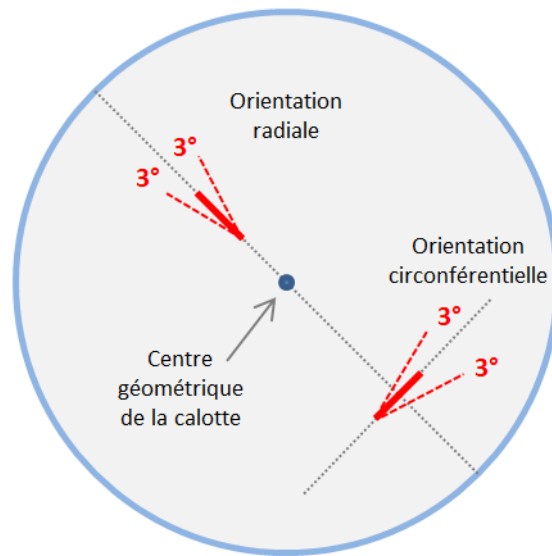

Figure 48: Orientation of flaws sought – dome top view

Radial orientation
Circumferential orientation
Geometrical centre of the dome

The rapporteur considers that, as no degradation mode is identified, the inspections cannot in principle be defined as a function of a particular flaw orientation.

The rapporteur considers that it would be possible to significantly increase inspection coverage, for example:

- by using a larger number of probes on the plate of the inspection machine;
- or by performing several inspection passes with the same probes and offsetting their orientation between passes.

Finally, the rapporteur notes that these inspections could be carried out as of the first complete requalification⁶¹ following commissioning, which would thus be performed ahead of the first ten-yearly outage inspection. The rapporteur considers this to be satisfactory.

The rapporteur considers that the anomaly does not call into question the serviceability of the reactor pressure vessel bottom head, provided that the reactor pressure vessel bottom head inspections are appropriate and can detect all flaws perpendicular to the surfaces, regardless of their orientation. It considers that the inspections planned by EDF, performed ahead of the first ten-yearly outage inspection and to which these adaptations would be made, are such as to significantly reinforce the second level of defence in depth and make up for the deterioration observed in the first level.

Reactor pressure vessel closure head dome

The rapporteur considers that inspections on the pressure vessel closure head are essential in order to reinforce the second level of defence in depth and, throughout the 60 years of operation

⁶¹ No later than 30 months after the first fuel loading.

of the reactor, confirm that no flaw with a height of more than 10mm is present in the segregation zone. This is reinforced by the presence of geometrical singularities linked to the adapters and operating conditions that are different from those of the bottom head (temperatures, closure head handling, etc.).

The rapporteur notes that the inspections to which EDF is committed cover a more restricted zone for the closure head than for the bottom head, more specifically because of the search zone limited to the shortest ligaments between adapters (Figure 49) and the impossibility of detecting all the flaws in the vicinity of the adapters (50% at nozzle corner, 80% in continuous part, see Figure 50). The rapporteur also notes that, as with the bottom head, only faults disoriented by less than 3° with respect to the search direction would be detectable. These restrictions imply that the proportion of flaws perpendicular to the surface and detectable in the outer first twenty millimetres is very small.

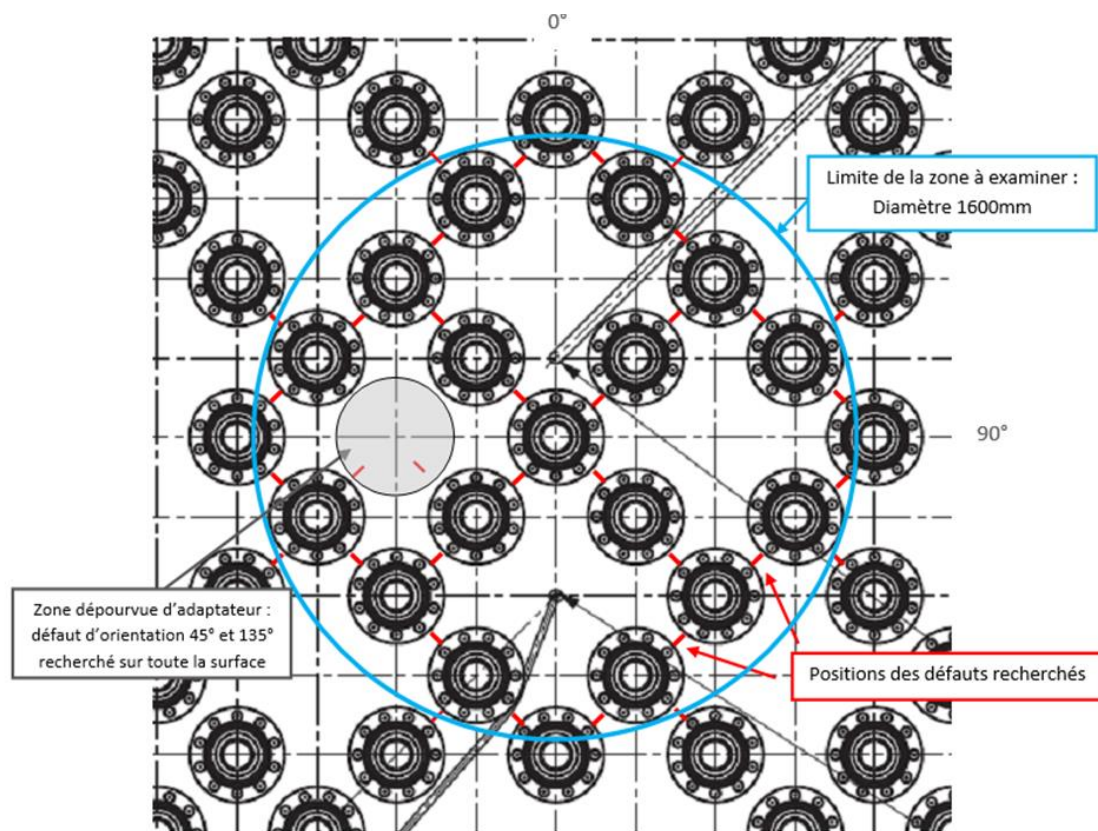

Figure 49: Central part of the Flamanville EPR reactor pressure vessel seen from above – zone to be examined and positions of flaws looked for

Limit of zone to be examined: Diameter 1600 mm

Zone free of adapter: flaw of orientation 45° and 135° sought over entire surface

Positions of flaws looked for

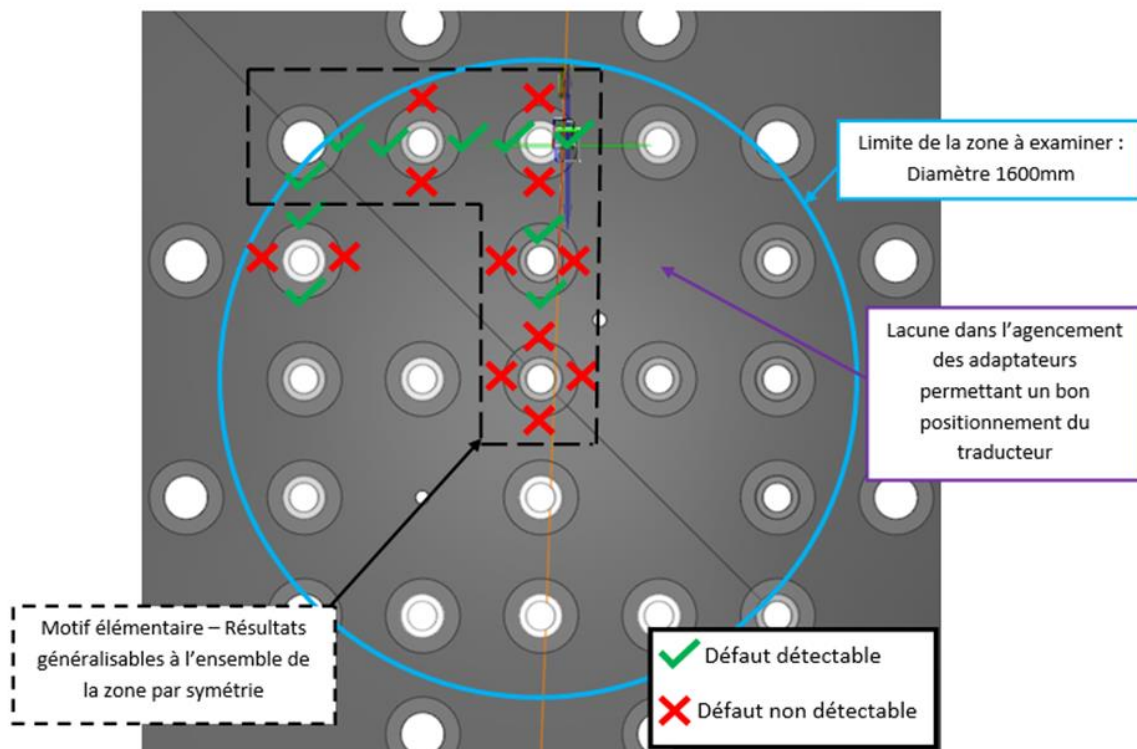

Figure 50: Central part of the Flamanville EPR reactor pressure vessel seen from above – possibility of detecting flaws in the immediate vicinity of the adapters

Limit of zone to be examined: Diameter 1600 mm
 Gap in layout of adapters allowing good positioning of transducer
 Basic pattern – Results could be applied to entire zone by symmetry
 Detectable flaw
 Non-detectable flaw

The rapporteur underlines the fact that the technical file transmitted by NP and EDF concerning the in-service inspections is extremely succinct, despite the discussions held with the rapporteur during the review. It provides no technical data on the feasibility of the inspections, their performance and the working conditions in terms of radiation protection. This file does not therefore permit the rapporteur to analyse the adequacy of the inspections to which EDF finally committed itself at the end of the examination process.

The rapporteur also notes that numerous reactor pressure vessel closure heads have been replaced in the past and that Areva NP considers the time needed to replace the Flamanville EPR reactor pressure vessel closure head to be less than 80 months (see Appendix 6). A new closure head, for which the manufacturing conditions would guarantee the absence of prejudicial residual carbon segregations could thus be available before the end of 2024 if its procurement were to be launched in 2017. On this subject, the rapporteur recalls that ASN asked Areva NP in December 2015, in the letter in reference [7], to initiate a study of the manufacture of a new pressure vessel closure head without delay, taking account of experience feedback from the design and manufacture of the existing one.

The rapporteur considers that the serviceability of the present closure head for the Flamanville EPR reactor pressure vessel cannot be confirmed on a long term basis, owing to the absence of sufficient in-service inspections to reinforce the second level of

defence in depth. The rapporteur notes that EDF is not able to perform in-service inspections on the closure head on the same scale and with the same deadlines as for the reactor pressure vessel bottom head.

The rapporteur considers that using the existing closure head on the Flamanville EPR reactor pressure vessel could not be envisaged beyond a few years of operation, unless the in-service inspections needed to reinforce the second level of defence in depth are implemented.

9. General conclusion

At the end of 2014, tests performed for technical qualification of the Flamanville EPR reactor pressure vessel domes revealed the presence of a positive carbon macrosegregation zone which had been insufficiently eliminated during the ingot discard operations. The presence of excess carbon in this zone leads to reduced material toughness, in other words, its ability to withstand crack propagation.

In the light of this deviation, Areva NP in 2015 proposed a demonstration approach based on an assessment of the risk of fast fracture of these components. This approach, the principle of which is relatively conventional, aims to demonstrate that in the segregation zone, this material is tough enough to preclude the risk of initiation of the largest flaw potentially present in each of the domes under the effect of the thermomechanical loads to which they can be exposed during operation.

Areva NP therefore:

- to determine the toughness of the material, carried out a test programme on three scale-one replica domes and demonstrated that they were representative of the Flamanville EPR reactor pressure vessel domes;
- to determine the largest flaw potentially present in each of the domes, carried out non-destructive test inspections;
- to determine the thermomechanical loadings, identified and characterised the NSSS transients liable to load the pressure vessel domes.

This approach was analysed by the GP ESPN at its sessions of 30 September 2015 and 24 June 2016. It was considered satisfactory by ASN in its letters in reference [7] and [10], provided that account is taken of a number of requests, to which Areva NP responded (see table in Appendix 15).

Areva NP carried out the various steps of this approach in 2016 and on 16 December 2016 and sent ASN a file demonstrating the serviceability of the Flamanville EPR reactor pressure vessel domes. This file was examined by the rapporteur, which drew the following conclusions.

*

Flamanville EPR reactor pressure vessel bottom head dome

Checks during manufacturing

At the dome procurement stage, Areva NP inspected the entire volume of the part, including the segregation zone. The results of these inspections revealed no flaw of dimensions exceeding the criteria in the technical specifications. The additional inspections performed at the request of ASN, also confirmed the absence of under-cladding flaws.

It was subsequently verified that the size of the flaws postulated in the Areva NP mechanical analyses was defined consistently with the performance levels of these inspections.

Characterisation of the material

In order to characterise the segregated material, Areva NP ran a test programme on scale-one replica domes, the scope of which is underlined by the rapporteur. The differences in steelmaking for the various domes lead to variations in mechanical properties which remain limited but the amplitude of which is hard to evaluate with certainty. This observation led the rapporteur to consider that the properties of the material must be assessed using an approach that is guaranteed and proven to be conservative.

The rapporteur observes that the presence of a residual carbon segregation is indeed the origin of the change in the mechanical properties. However, the behaviour observed remains that expected of a ferritic steel. The modification of the mechanical properties mainly results in an increase in the transition temperature between the brittle behaviour of the material and its ductile behaviour, of a few tens of degrees, depending on the assessment method used.

The rapporteur considers that it was necessary for Areva NP to assess the properties of the material of the Flamanville EPR reactor pressure vessel domes on the basis of the results of its test programme, using a proven approach whose conservative nature is absolutely guaranteed. Consequently, the fact that Areva NP adopted a transition temperature rise between the brittle fracture mode and the ductile mode equal to the maximum shift in the nil ductility reference temperature (RT_{NDT}) between the segregation zone and the tested domes acceptance zone is satisfactory.

Finally, EDF undertook to carry out a test programme to validate the hypotheses considered for thermal ageing of the material, which is satisfactory.

Thermomechanical loadings

The thermomechanical transients examined by Areva NP to determine the most severe thermomechanical loadings applying to the pressure vessel bottom head dome, were analysed by the rapporteur, considering the hot shock and cold shock situations each time.

The rapporteur underlines the fact that, following the in-depth examination of this file and the numerous exchanges which took place during the examination, Areva NP transmitted elements enabling it to complete its initial file and consolidate its demonstration.

The approach adopted by Areva NP to identify the situations causing the most severe loadings of the reactor pressure vessel domes is considered to be satisfactory by the rapporteur, as is the conservative nature of the loads which were deduced from it.

Mechanical analysis of the fast fracture risk

The evaluation of the fast fracture risk carried out by Areva NP is consistent with the approach prescribed by the RCC-M code, with regard to the choice of flaws analysed, the definition of the minimum toughness and the evaluation of the stress intensity factors. The conclusions of this analysis show that the mechanical properties of the material in the segregation zone are sufficient to preclude the risk of fast fracture.

Irregularities detected in the Creusot Forge plant

The reactor pressure vessel head domes were manufactured during a period for which irregularities have been detected within the Creusot Forge plant.

At the request of ASN, Areva NP repeated the mechanical tests and non-destructive test inspections initially performed by Creusot Forge on the various domes. These new tests and inspections, the results of which are satisfactory, provide additional guarantees as to the quality of the parts concerned and the absence of any deviation liable to compromise the representativeness of the various domes.

In-service inspection

The rapporteur considers that the shortcomings observed in the technical qualification process, the use of a manufacturing process which was unable to rule out risks linked to residual carbon segregation and the reduction of fast fracture risk margins, reflect the fact that the first level of defence in depth is affected. The Areva NP demonstration approach is unable on its own to restore this first level of defence in depth.

Given that failure of the reactor pressure vessel domes is not postulated in the Flamanville EPR reactor safety case, the rapporteur considers that the demonstration approach proposed by Areva NP needs to be completed by in-service inspection of the pressure vessel domes.

The rapporteur considers that the anomaly does not call into question the serviceability of the reactor pressure vessel bottom head, provided that the reactor pressure vessel bottom head inspections planned by EDF are appropriate and can detect all flaws perpendicular to the surfaces, regardless of their orientation. It considers that these inspections, performed ahead of the first ten-yearly outage inspection and to which these adaptations would be made, are such as to significantly reinforce the second level of defence in depth and make up for the deterioration observed in the first level.

*

Flamanville EPR reactor pressure vessel closure head dome

Checks during manufacturing

At the procurement stage, Areva NP carried out the volume and surface inspections specified by the RCC-M code. These inspections did not reveal any flaw with dimensions not conforming to the criteria in the technical specifications.

However, unlike the reactor pressure vessel bottom head, it was not possible to carry out additional non-destructive test inspections on the outer surface, in order to detect any surface-breaking flaws filled with oxide. Areva NP provided evidence that the manufacturing processes are such as to preclude the presence of flaws perpendicular to the surface, of dimensions not-conforming to the criteria in the technical specifications.

The size of the flaws postulated in the Areva NP mechanical analyses is consistent with the performance levels of these inspections.

Characterisation of the material

The characterisation of the material of the closure head dome revealed no notable difference with respect to that of the material of the bottom head dome.

Thermomechanical loadings

The thermohydraulic transients used to define the most severe thermomechanical loadings applied to the reactor pressure vessel closure head dome, in the various situation categories, were examined and analysed in the same way as for the reactor pressure vessel bottom head dome.

In the same way as for the reactor pressure vessel bottom head dome, the rapporteur has no remarks concerning the definition of the loadings on the closure head dome.

Mechanical analysis of the fast fracture risk

The evaluation of the fast fracture risk carried out by Areva NP for the reactor pressure vessel closure head follows a process very similar to that used for the reactor pressure vessel bottom head.

The conclusions of this mechanical analysis show that the mechanical properties of the material in the segregation zone are sufficient to preclude the risk of fast fracture.

Irregularities detected in the Creusot Forge plant

As with the reactor pressure vessel bottom head and at the request of ASN, Areva NP repeated the mechanical tests and non-destructive test inspections initially performed by Creusot Forge on the various domes. These new tests and inspections, the results of which are satisfactory, provide additional guarantees as to the quality of the parts concerned and the absence of any deviation liable to compromise the representativeness of the various domes.

However, unlike with the reactor pressure vessel bottom head, the rapporteur notes that these volume inspections using non-destructive manufacturing tests could not be repeated, owing to the items installed on the closure head.

In-service inspection

The rapporteur considers that inspections on the reactor pressure vessel closure head are essential in order to reinforce the second level of defence in depth and, throughout the reactor operating period, verify that no flaw with a height of more than 10mm is present in the segregation zone. These inspections are all the more necessary as the closure head comprises geometrical singularities owing to the adapters and has operating conditions that are different from those of the bottom head (temperatures, closure head handling, etc.).

The rapporteur underlines the fact that the technical file transmitted by Areva NP and EDF on the in-service inspections is extremely succinct and gives no technical data on the feasibility of the inspections, their performance and the working conditions in terms of radiation protection.

The rapporteur therefore considers that the serviceability of the present closure head for the Flamanville EPR reactor pressure vessel cannot be confirmed on a long term basis, owing to the absence of sufficient non-destructive inspections to reinforce the second level of defence in

depth. The rapporteur notes that EDF is not at present able to perform non-destructive inspections on the closure head on the same scale and by the same deadlines as for the reactor pressure vessel bottom head.

The rapporteur therefore considers that using the existing closure head on the Flamanville EPR reactor pressure vessel could not be envisaged beyond a few years of operation, unless the inspections needed to reinforce the second level of defence in depth are implemented.

* * *

Appendix 1: Tables and figures

List of tables

List of tables in appendices

List of figures

List of figures in appendices

Not translated

Appendix 2: Diagrams and components of the Flamanville EPR reactor pressure vessel

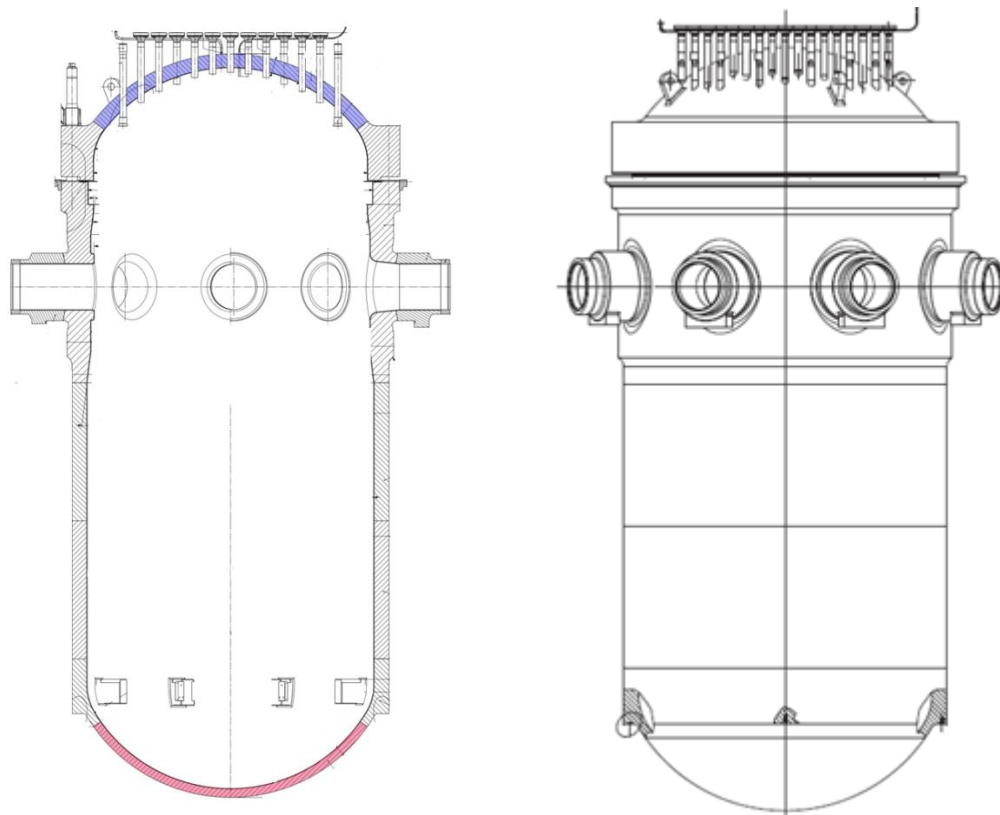

Figure A1. : Diagrams and components of the Flamanville EPR reactor pressure vessel
The domes are indicated in colour.

| Reactor pressure vessel body | Reactor pressure vessel head |
|--|--|
| <p>The RPV body comprises the following elements, from bottom to top:</p> <ul style="list-style-type: none"> - bottom section: <ul style="list-style-type: none"> - a lower bottom (dome), - a transition ring, - 8 radial guides. - cylindrical shell: <ul style="list-style-type: none"> - 2 core shells - one nozzle shell, - 4 inlet nozzles, - 4 outlet nozzles, - 8 safe ends, - one reactor pressure vessel seal ledge, - one leak monitoring tube. | <p>The RPV closure head comprises the following elements:</p> <ul style="list-style-type: none"> - one RPV closure head flange; - an upper dome; - 89 CRDM adaptor tubes; - 89 CRDM adaptor flanges; - 16 instrumentation adaptor tubes, equipped with lower section guiding cones; - 16 instrumentation adaptor flanges; - one vent branch connection; - one dome temperature measurement nozzle and its endpiece; - 4 lifting lugs. |

Appendix 3: Diagram of the primary cooling system and connected systems, particularly the RIS-RA system

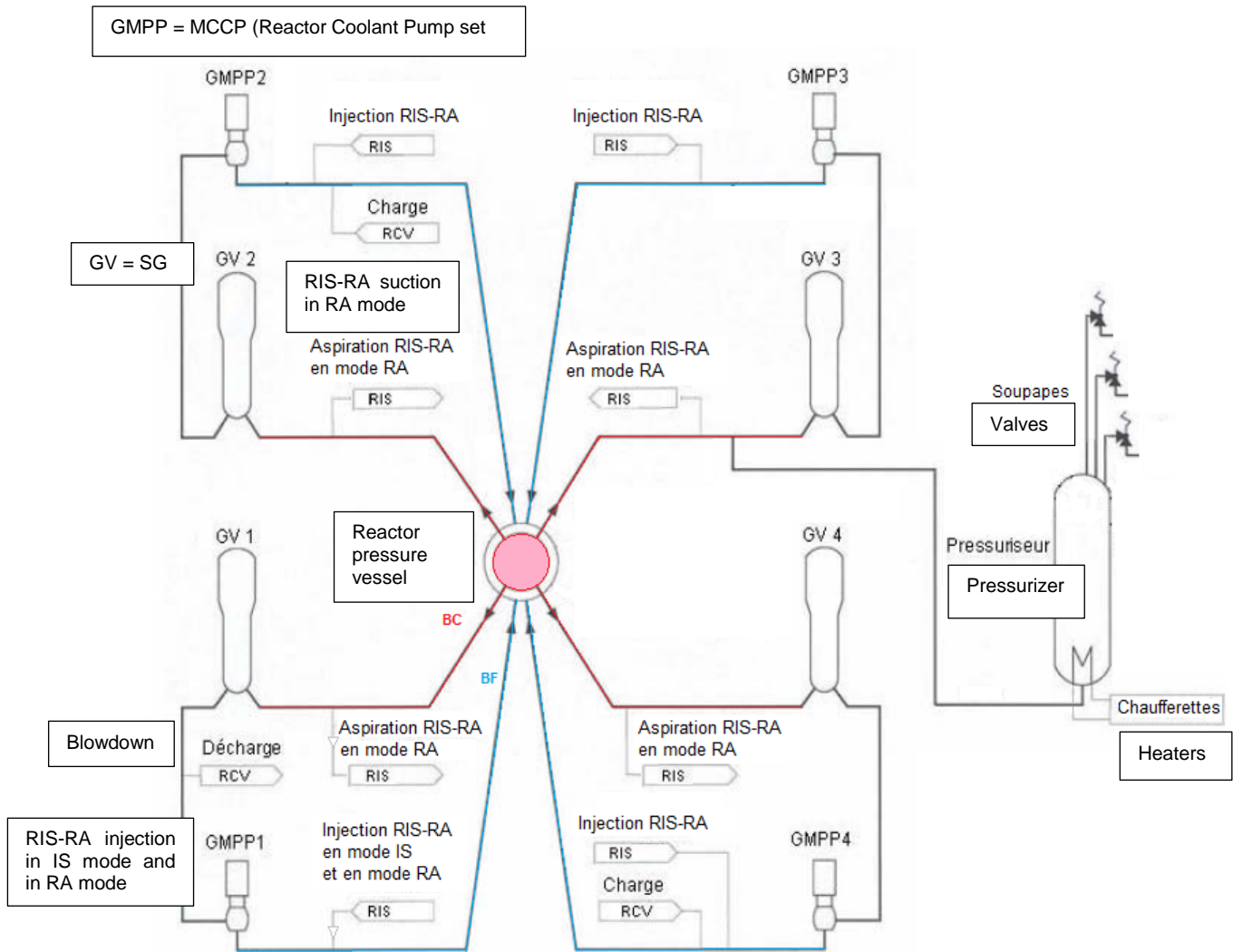

Figure A2 : Diagram of the RIS-RA system connected to the primary cooling system

Appendix 4: Analysis of the thermomechanical loadings - Points common to the thermohydraulic situations of hot shock and cold shock

In this annex, the rapporteur analyses the common points between the hot shock and cold shock situations which constitute:

- the penalising nature of the estimation of the heat transfer coefficient between the fluid and the structure used to characterise the relevant situations that do not involve a transfer coefficient of infinite value;
- the penalising nature of the thermohydraulic parameters of the category-2 operating situations which are defined by the normal operational control rules.

Exchange coefficient

For certain hot shock or cold shock situations, Areva NP uses a variable exchange coefficient (according to the flow velocity in particular) drawn from correlations in the literature. As this is a dominant parameter, the rapporteur asked Areva NP to adopt an exchange coefficient multiplied outright by two in order to take the associated uncertainties into account.

Furthermore, for the lower dome, the flow velocity (parameter in the calculation of the exchange coefficient in forced convection) is determined from the flow rate and the flow cross section at the bottom of the annular downcomer. But the analysis of a CFD (computational fluid dynamics) three-dimensional local thermohydraulic calculation carried out by Areva NP shows that this choice can result in a serious under-estimation of the flow velocity along the wall and hence of the exchange coefficient. Further to this finding, Areva NP revised its file by re-evaluating, on the basis of the CFD calculation [61], the velocity for each cold shock situation concerned [62]. However, for all the situations concerned these re-evaluations use the results of a single CFD calculation simulating the injection of 50 kg/s of cold water at 15 °C into each of the loops starting from an initial state at 250 °C. The velocity adopted is based on the CFD calculation and corrected with respect to the injected flow rates. The rapporteur estimated that, in the absence of sensitivity studies, the use of a single CFD was not sufficient to guarantee that its use, for extremely varied configurations, enables envelope velocities to be obtained.

At the end of the examination, Areva NP transmitted [82] complementary CFD calculations which show that its extrapolation hypothesis on the sole basis of the calculation at 50 kg/s lead in all cases to a conservative evaluation of the velocities at the RPV lower head and therefore to a conservative estimate of the heat transfer coefficient. The rapporteur has no particular comments to make on this point.

Characterisation of category-2 situations – Upper dome and lower dome

The worst-case category-2 transients for the domes are the 20xxxx situations. More specifically, 20E–3P situations (situations of cold overpressure linked, for example, to inadvertent starting of safety injection) induce greater loads on the lower dome, while in 20A345b situations (situations of temperature fluctuation in Single-phase cold shutdown condition) the upper dome is more heavily loaded. These situations are defined by variations in temperature and pressure which take account of the operating experience feedback from the reactors in service. Areva NP considers that they cover the variations that will effectively be observed on the Flamanville EPR reactor in normal operation. Although it is impossible to express an opinion on the degree of conservatism of these characterisations as there is no operating experience feedback for the Flamanville EPR reactor, the rapporteur considers that the normal operating rules guarantee compliance with the limits of the characterisation of the worst-case category-2 transients.

In this respect, following the discovery of residual positive macro-segregations of carbon in a number of steam generator channel heads, EDF has introduced modifications in the operating rules for the reactors concerned [63]. The rapporteur has therefore asked Areva NP to draw up a comparative assessment of the operational control rules for the reactor fleet in operation and for the Flamanville ERP reactor. This assessment is presented in Table A1 and Table A2.

| Compensatory measures for the proof tests of the fleet's segregated SG channel heads | Objective of the measure with respect to the SG channel heads of the 900 and N4 plant series | Areva NP's analysis of the need to tighten the operational control rules with respect to FA3 RPV domes |
|---|---|--|
| Shutdown of the last MCCP possible if temperature difference between RRA discharge at SG outlet is less than 30°C | Guarantee limitation of the amplitude of the hot shocks (plug situated in the SG tubes) at 30°C, the value adopted in DDS 900. | The calculations of mechanical robustness show that this scenario of entrainment of a hot plug (T _{max} = 55°C/120°C) formed in the SGs is not harmful for the RPV domes → No change in operational control rule necessary. |
| Reduction in cooling gradients below 120°C and heating gradients below 60°C to 14°C/h when primary system is Single-phase | Optimisation of category-2 situations (situations 1X and 2X) to restore mechanical margins. Compensatory measure necessary to guarantee positive margins. | The profiles of the EPR DDS (cooling situations) are substantiated by the mechanical calculations → No change in operational control rule necessary. |
| Guarantee T _{RCP} ≥ 30°C in AN/RRA (before primary system depressurisation and water movements with the pool) | Optimisation of category-2 and -3 situations initiated in AN/RRA to restore mechanical margins. Compensatory measure necessary to guarantee positive margins. | The profiles of the EPR DDS are substantiated by the mechanical calculations → No change in operational control rule necessary. |
| Request to depressurise primary system to 7 bars as soon as possible after shutting down the last MCCP and after the periodic tests | Optimisation of category-2 situations (instantaneous cold shocks) to restore mechanical margins. Compensatory measure necessary to guarantee positive margins. | The EPR DDS profiles (instantaneous cold shock 55°C - 15°C at 55 bar) are substantiated by the mechanical calculations → No change in operational control rule necessary. |
| Limitation of IJPP ⁶² temperature with MCCP sets shut down: limitation of ΔT between RRA discharge and IJPP injections to 15°C max | Optimisation of category-2 situations (instantaneous cold shocks) to restore mechanical margins. Compensatory measure necessary to guarantee positive margins. | The EPR DDS profiles (instantaneous cold shock 55°C - 15°C at 55 bar) are substantiated by the mechanical calculations → No change in operational control rule necessary. |

Table A1 : Analysis of the need to tighten the operational control rules

⁶² IJPP: Injection at reactor coolant pump (MCCP) seals

| Compensatory measures for the proof tests of the fleet's segregated SG channel heads | Objective of the measure with respect to the SG channel heads of the 900 and N4 plant series | Areva NP's analysis of the need to tighten the operational control rules with respect to FA3 RPV domes |
|--|---|--|
| SG cycling prohibited if ΔT between RRA discharge and TASG is greater than 15°C | Guarantee a limitation of the amplitude of cold shocks (plug resulting from thermal balancing between the tube bundle and the secondary system filled by the ASG, without considering the gravity flow of the cold plug) at 15°C. Hypothesis necessary to guarantee positive margins. | The EPR DDS profiles (instantaneous cold shock 55°C - 15°C at 55 bar) are substantiated by the mechanical calculations. Moreover, SG cycling is not included in EPR operational control → No change in operational control rule necessary. |
| Limitation of pressuriser heterogeneity $T_{\text{liquid phase PZR}} - T_{\text{RIC}} < 15^\circ\text{C}$ (use of auxiliary spraying if necessary) | Limit the formation of a hot plug at the pressuriser to guarantee compliance with the 15°C amplitude considered in the DDS. | The hot plug in the pressuriser cannot circulate in the RPV → No change in operational control rule necessary. |
| Stopping of the last MCCP at 35°C | Cool down the tube bundle to a temperature close the minimum temperature of the RCP to limit the temperature difference between the bundle and the RCP. Although the amplitude of the thermal shock when these plugs start moving is limited by the compensatory measure on the temperature of the VVP metal, this compensatory measure has been maintained in order to practically eliminate the hot plugs on shutdown of the MCCP displaying low margins due to summing with the seismic loads) | The instantaneous cold shock 55°C-15°C considered in the EPR DDS does not pose a substantiation problem, and the start of movement of any hot plugs situated in the SG tubes is not harmful for the RPV domes → No change in operational control rule necessary. |
| Disconnection of MCCP sets further to normal or incidental shutdown | Render the entrainment of a hot or cold plug impossible | Disconnection of MCCP sets already specified in EPR → No change in operational control rule necessary. |

Table A2 : Analysis of the need to tighten the operational control rules (cont'd)

Areva NP concludes from this that it is not necessary to provide for changes in the planned operational control rules for the Flamanville EPR for the following reasons:

- some of the operating measures added for the reactors in service are already planned for in the normal operational control rules of the Flamanville EPR reactor, such as disconnection of the MCCP sets after their normal shutdown;
- certain operations that can create a cold shock are not planned to be implemented on the Flamanville EPR reactor, such as SG cycling⁶³;
- the RPV domes are mechanically less heavily loaded than the SG channel head in the event of an earthquake⁶⁴.

It should be noted that for the reactors in service, it has been requested that during a reactor outage, the last MCCP only be shut down if the temperature difference between the RRA discharge and the metallic masses at the SG outlet on the secondary cooling system side is below 30°C. This measure guarantees a limitation of the amplitude of the hot shocks to 30°C if a plug of hotter water formed in the SG tubes should be transferred into the SG channel heads. For the

⁶³ Steam generator cycling is a control operation that speeds up the cooling of the secondary cooling system side in order to be able to start working on it sooner. It consists in filling the secondary cooling system with cold water then emptying it, and repeating this several times.

⁶⁴ For information, the design basis rules in effect require the loads due to an earthquake to be summed with the other loads in category-2 situations.

Flamanville EPR reactor, at the request of the rapporteur, Areva NP performed robustness calculations [65] which show that a scenario in which a 120°C hot plug is transferred is not harmful for the RPV domes. It concludes from this that this compensatory measure is not necessary for the Flamanville EPR reactor.

Likewise, to prove that no change to the normal operational control rules is necessary, Areva NP indicates that the instantaneous cold shock from 55°C to 15°C at 55 bar considered in the Flamanville EPR reactor DDS (situation 20E-3P, including more specifically inadvertent starting of safety injection) is not harmful for the RPV domes and covers the feared situations. However, the rapporteur observes that this shock does not stress the upper dome (as the cold water from the safety injection does not reach the upper dome). Furthermore, this is a thermal shock postulating shutdown of the reactor main coolant circulation pumps (MCCP) which therefore does not cover the situations where they are operating. Lastly, for the reactors in operation, the rapporteur observes that the instantaneous thermal shocks (hot and cold) with the MCCPs in operation are considered. But the equivalent situations for the Flamanville EPR reactor are based on less penalising temperature gradients of 40 to 50°C/h. Consequently, the rapporteur asked Areva NP to evaluate the effect of instantaneous thermal shocks (hot and cold) with the MCCP sets in operation for both RPV domes.

Areva NP carried out this robustness study even though it considered that the requested characterisation does not correspond to any identified initiating event. The study shows that the design-basis modelling of situation 20A345b of category-2 primary system fluctuations by a square waveform is effectively more penalising for both domes and provides a means of checking that any foreseeable malfunction in the control systems and the systems is covered with respect to the fast fracture risk in category-2 situations.

In view of the elements provided during the technical examination, the rapporteur considers that it is acceptable not to plan for changes in the normal operational control rules for the EPR reactor. However, insofar as these rules limit the amplitude of the cold shock and hot shock transients on the RPV domes during normal and disrupted operation (category-2 situations), the rapporteur considers that, in respect of this, the corresponding criteria must figure in the technical operating specifications (STE) of the general operating rules (RGE).

Appendix 5: Thermomechanical loadings - Characterisation of hot shock transients

In this appendix the rapporteur presents the characterisation of hot shock transients proposed by Areva NP and analyses the appropriateness of the characterisation for the worst-case transients.

1) Code overpressure transients (DDS)

During the examination, the rapporteur asked Areva NP to prove the bounding nature, as regards the loading applied to the upper dome, of the assumptions used in the description of the single-phase low-temperature overpressure situation associated with inadvertent activation of safety injection (IS). This is because in this situation, the initial temperature considered at the time of the safety injection is 55°C (maximum temperature allowing shutdown of the last reactor main coolant pump - MCCP). Although this choice aims at maximising the cold shock in the annular downcomer and on the lower dome (from 55°C to 15°C), the thermal shock does not induce loads in the upper dome given that the MCCPs are shut down. However, considering the primary fluid temperature to be 15°C (the minimum feasible temperature), inadvertent triggering of fuel injection could induce a low-temperature overpressure that is more penalising for the upper dome. Areva NP has reviewed [57] the primary system overpressure situations initiated at a temperature of 15°C. It concludes that, with respect to an upper dome outer surface flaw, this new initial state is more penalising than the state initially adopted, while nevertheless remaining acceptable. **The rapporteur considers these elements to be satisfactory and has no further comments on the characterisation method chosen by Areva NP for this situation.**

2) Hot shock transients not considered in DDS

Areva NP provided notice [47] presenting an analysis of the hot shock situations not considered in the DDS which are penalising for the lower and upper domes. The characterisation of these situations gave rise to numerous discussions during which a number of assumptions considered non-conservative by the rapporteur were modified. The summary note relative to hot shock situations [43] and its revision [44] set out the characterisations chosen for each additional situation.

The worst-case transients are induced by a small-break LOCA and a total loss of cooling by the shut down cooling system (RIS-RA in RA mode).

a) Hot shock transient No. 1 not considered in DDS: Connection of RIS-RA in RA mode further to small-break LOCA (category 3)

Further to the appearance of a small break and depressurisation of the primary cooling system, the four RIS-RA trains came into service in IS (safety injection) mode to compensate for the loss of mass. Insofar as shutdown of the reactor main coolant circulation pumps (MCCP) occurs during the accident scenario, entry into service of the trains initially induces a cold shock on the lower dome further to the loss of natural circulation. Then, under certain conditions, the operator will be able to stop the RIS-RA trains in IS mode and switch them to RA mode (cooling during shutdown) one after the other. When RIS-RA connection takes place in RA mode, the hot water drawn into the hot legs is reinjected in the cold legs and the RPV, which can cause a hot shock on the lower dome.

Areva NP considers that the design-basis hot shock is associated with entry of the first RIS-RA train into RA mode. The bounding thermohydraulic loading adopted [43] corresponds to an instantaneous hot shock from 15°C to 128°C considering the maximum flow rate delivered by an RIS-RA pump in RA mode (i.e. 555 m³/h) and a minimum IS flow rate corresponding to a 20 cm² break (i.e. 270 m³/h). The maximum hot shock temperature (128°C) corresponds to the

perfect mixing temperature between the RIS-RA flow in RA mode coming from the hot legs considered at 180°C (maximum RIS-RA connection temperature in RA mode) and the safety injection flow rate. Areva conservatively considers an infinite exchange coefficient between the fluid and the wall.

During the examination the rapporteur questioned Areva NP on the conservative nature of the assumptions used. In effect, choosing a smaller break size could lead to a lower safety injection flow rate and therefore a higher mixing temperature.

Consequently, Areva NP recalculated the scenario for RIS-RA connection in RA mode, considering a break size of 5 cm² (the smallest size of break leading to the stopping of natural circulation in the primary cooling system). However, for the characterisation of this new transient, Areva NP relaxed the conservative assumption associated with the hot water plug temperature (180°C). Areva NP thus studied two configurations that differ in the operational control actions to take according to the core exit temperature (higher or lower than 135°C). For each case, Areva NP defined a new temperature profile, justified in notice reference [44] (see Figure A3 and Figure A4).

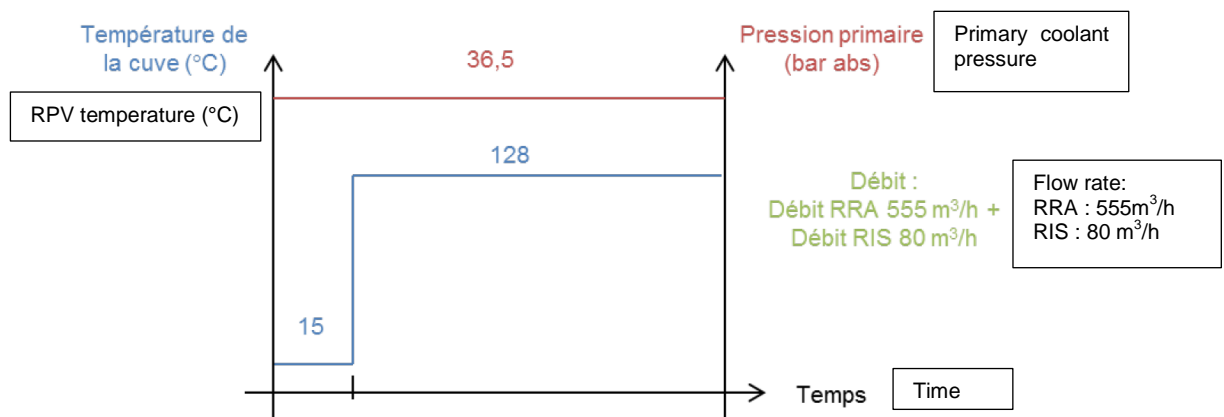

Figure A3 : Fluid temperature and primary coolant pressure profiles applicable at RPV lower head in case of connection of an RIS-RA train in RA mode with $T_{\text{core exit}} > 135^{\circ}\text{C}$ (case 1)

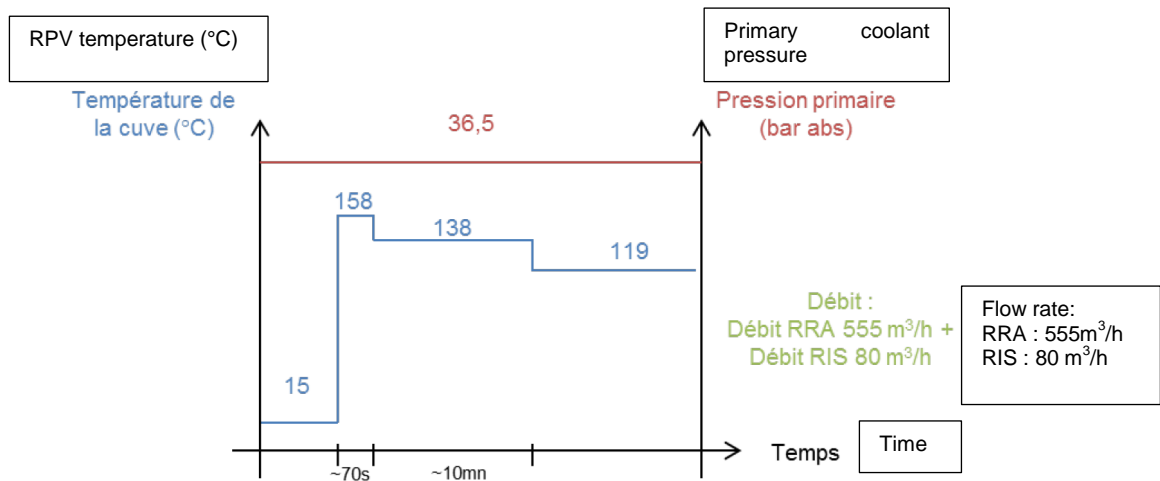

Figure A4: Fluid temperature and primary coolant pressure profiles applicable at RPV lower head in case of connection of an RIS-RA train in RA mode with $T_{core\ exit} > 135^{\circ}C$ (case 2)

The worst-case temperature profile is the case where RIS-RA connection in RA mode takes place with a core exit temperature below $135^{\circ}C$, the hot leg temperature being below $180^{\circ}C$ (condition for connection of RIS-RA in RA mode). In this case the RPV lower head can be subjected to a hot shock from $15^{\circ}C$ to $158^{\circ}C$ corresponding to the mixing temperature between the flow from the RIS-RA in RA mode drawn into the hot leg at $180^{\circ}C$ and the RIS flow at $15^{\circ}C$. This first plateau lasts for the time it takes empty the water at $180^{\circ}C$ contained in the hot leg of the SG inlet channel head. Subsequently, the temperature of water drawn into the hot leg by the RRA will result from the mixing of the water contained in the SG tubes, the channel head and the U-branch at 180° and the water at the core exit at $135^{\circ}C$, then the mixing of this flow with the safety injection water injected into the cold leg. The resulting temperature is $138^{\circ}C$. Once the water contained in the leg is evacuated, the temperature at the RPV lower head ($119^{\circ}C$) results from the mixing of the water injected by the RIS-RA in RA mode at the core exit temperature ($135^{\circ}C$) and the safety injection flow.

Areva NP considers [44] that applying the mixing temperature between the RIS-RA flow in RA mode and the IS flow directly to the RPV lower head without taking into account mixing with the volume of cold water contained in the annular space and the RPV lower head constitutes a conservative assumption. Furthermore, the hot thermal shock is considered to be instantaneous. Given the low injection flow rate of the RIS-RA system in RA mode (about 150 kg/s), the rapporteur agrees that ignoring the volume of cold water contained initially in the RPV and adopting the instantaneous thermal shock hypothesis leads to a conservative situation.

Furthermore, Areva NP indicates that the IS flow rate of $80\text{ m}^3/\text{h}$ used in the study is determined considering a penalising assumption for the head losses leading to minimising of the flow rate lost at the break and the injected IS flow rate, and thereby maximising the calculated mixing temperature. The rapporteur considers that this assumption increases the conservative nature of the temperature profile adopted for this situation.

Lastly, ignoring the heat exchanger between the RIS-RA and the RRI (component cooling water system - CCWS) which cools the water drawn into the hot leg before reinjecting it into the cold leg in order to cool the primary cooling system also adds to the conservatism of the study.

The rapporteur thus considers that, despite the relaxation of the assumptions concerning the temperature of the hot water plug, the profiles adopted by Areva NP remain equivalent to or more penalising than the initially chosen profile.

To conclude, the rapporteur considers the temperature profiles established for the hot shock transient induced by connection of the RIS-RA in RA mode further to a small-break LOCA (category 3) to be conservative.

- b) Hot shock transient No. 2, not considered in DDS:** Resumption of natural circulation (RCN) further to a small-break LOCA initiated in state A or B (categories 3 and 4)

Further to partial emptying of the primary cooling system induced by the break, natural circulation stops and a regime of heat exchange in heat pipe mode⁶⁵ with the steam generators (SG) is established. The steam produced in the core condenses in the SGs and this hot water condensate accumulates in the SG tubes and channel heads. The temperature in this zone at the most equals the saturation temperature of water at the primary coolant pressure. At the same time, the RIS system cools the annular downcomer and the RPV lower head by injecting cold water. After a certain length of time, filling of the primary cooling system begins via the safety injection systems, then, if the break size is sufficiently small, natural circulation resumes and entrains the hot water plug accumulated in the loops towards the RPV lower head. In view of shutdown of the primary coolant pumps⁶⁶ during this accident, Areva NP considers that the induced thermomechanical loadings are only applicable to the lower dome.

The hot shock takes place at the moment of natural circulation resumption (RCN), which depends in particular on the size of the break and the safety injection flow rates. Areva NP developed a three-stage approach to characterise the thermohydraulic parameters associated with the RCN at any moment of a small-break LOCA of 20 cm² or smaller and varying the parameters relative to the IS and the RCN flow rate. The principle of this approach figures in the notice reference [43].

The approach is broken down into three stages:

- stage 1: RPV cooling results from injection of the IS flows, which induce a cold shock on the lower dome. The initial thermal shock temperature is the minimum temperature of the metal T_{PE} at the outer surface of the domes the moment RCN begins;
- stage 2: the final temperature of the thermal shock corresponds to the maximum fluid temperature T_f at the RPV lower head further to the RCN and entrainment of the hot water plug towards the RPV. T_f corresponds to the perfect mixing temperature between the "hot" natural circulation flow in the primary cooling system and the "cold" flows from safety injection (see Figure A5);
- stage 3: the mechanical analysis of the RPV is carried out on the basis of an instantaneous hot shock from T_{PE} to T_f .

For the purpose of simplification, stages 1 and 2 of the process are uncoupled in order to maximise the initial cold shock and then the hot shock when RCN takes place (Figure A5).

The cold shock is thus characterised by RPV cooling induced by the maximum flows delivered by

⁶⁵ Unlike normal operation in which the power generated by the core is transferred from the primary cooling system to the secondary cooling system by circulation of water in liquid phase on the primary system side, in heat pipe mode the primary coolant is vaporised when it crosses the core then condensed when it passes through the steam generators and finally returned to liquid form at the core inlet. In this case the power is evacuated due to the condensation in the SG tubes.

⁶⁶ On shutdown of the MCCPs, the dome sweeping flow cancels itself and the dome is no longer cooled.

the four IS trains in service and a hot leg break. The hot shock is characterised with the minimum flows from two IS trains, which corresponds to a cold leg break, while considering the third train to be undergoing maintenance and the fourth losing its flow at the break.

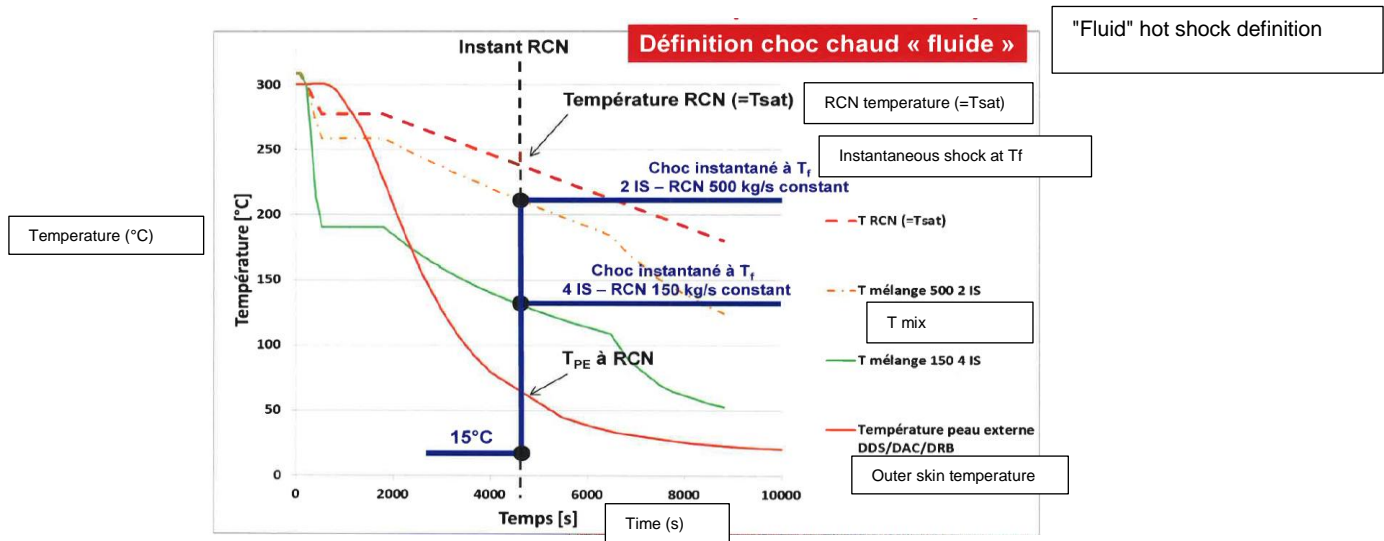

Figure A5: Principle of the Areva NP approach to characterise the category-3 hot shock resulting from the RCN situation following a small break

Furthermore, the RCN flow profile adopted by Areva NP is based on the results of the PKL tests (small-scale experimental installation of a German pressurised water reactor of the Konvoi type) transposed to the scale of the Flamanville EPR reactor. It also takes into account the conclusions of the examination of the inherent dilution studies following a small-break LOCA: the assumption taken is a constant flow rate of 500 kg/s for 100 seconds then a drop in flow rate to 200 kg/s in 50 seconds (see black curve in Figure A6).

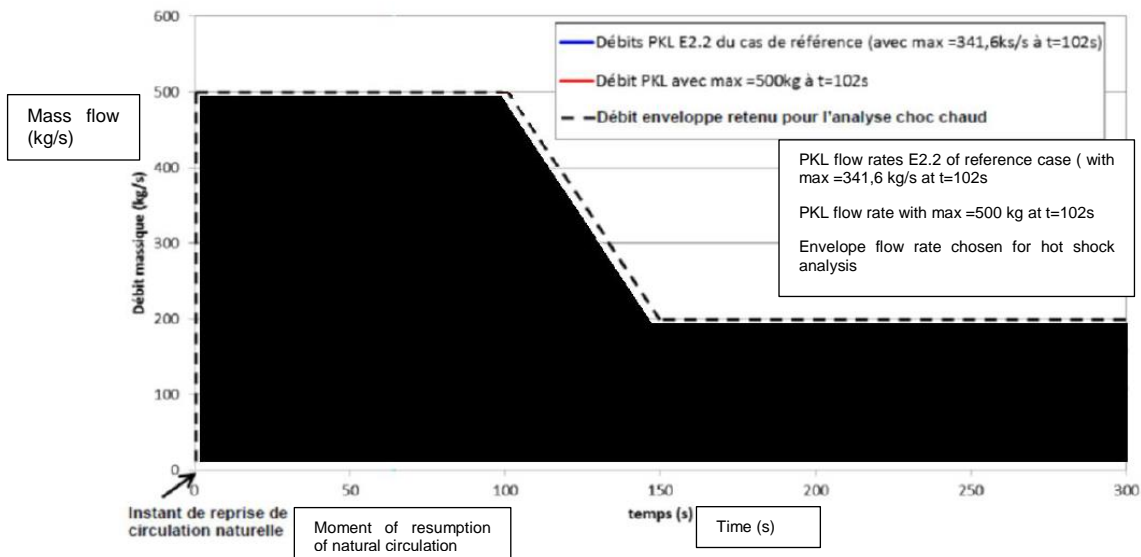

Figure A6: RCN flow rate profile used for the hot shock characterisation

Application of this approach leads Areva NP to use the thermohydraulic loadings (temperature variation) shown in Figure 7 as a function of the moment RCN takes place.

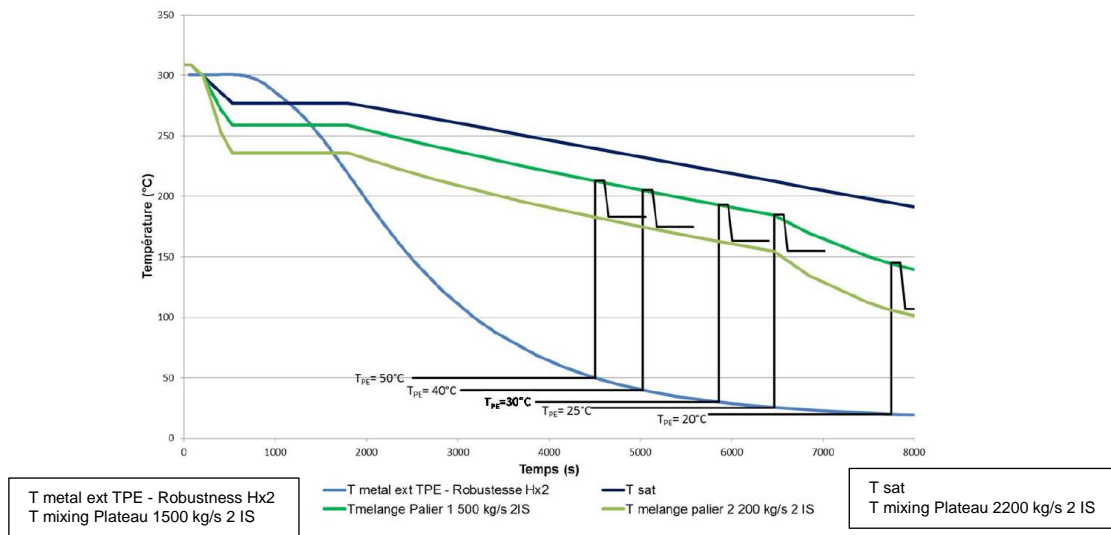

Figure A7: Characterisation of the hot shock caused by the RCN further to a small break in the primary cooling system

The characterisation of this transient considers a perfect exchange between the fluid and the wall (infinite exchange coefficient H) when the RCN flow rate equals 500 kg/s, followed by an exchange that encompasses the exchanges by natural convection (H_{CN}) and forced convection (H_{CF}) (with the following relation: $H = 2 \times \max(H_{CN}; H_{CF})$) when the RCN flow rate stabilises at 200 kg/s.

According to Areva NP, the worst-case category-3 transient is obtained when natural circulation resumes in a loop, considering injection by two IS trains in service (with a third IS train undergoing preventive maintenance and the fourth losing its flow directly at the break) with an initial RPV external wall temperature of 30°C.

To complete this analysis, Areva NP also studied this transient with more conservative assumptions by considering category-4 criteria. The final thermal shock temperature is thus taken as being equal to the saturation temperature (ignoring the mixing of the cold water from the IS with the hot water of the plug) and the exchange coefficient between the fluid and the wall is considered to be infinite. Areva NP considers that this complementary study covers the cases where resumption of natural circulation takes place in several loops simultaneously.

The rapporteur points out that the characterisation initially chosen by Areva NP in notice [47] was an instantaneous thermal shock from 15°C to 120°C. The final thermal shock temperature was obtained by considering a perfect mix between the hot water plug entrained towards the RPV and the flow from the four available safety injection trains. The rapporteur questioned Areva NP on the penalising nature of the assumptions used to describe this scenario (moment and pressure of RCN, final shock temperature, RCN flow rate and number of loops concerned, number of IS trains available) in view of the antagonistic effects between some parameters. These questions led Areva NP to develop an uncoupled approach, presented earlier, aiming to ensure the penalising nature of the thermomechanical loading calculated independently of the moment RCN occurs and the size of the break.

First of all, the rapporteur considers this uncoupled approach to be satisfactory in principle. It effectively simplifies the approach by limiting the number of sensitivity studies to perform when there are numerous parameters with antagonistic effects, in order guarantee the conservative nature of the chosen characterisation.

However, the analysis of this approach prompted a number of remarks concerning the following assumptions: the ignoring of primary cooling system pressure being maintained by the low head safety injection (LHSI) system, the taking into account of the reduction in RCN flow rate and the number of loops concerned by RCN. These points are detailed below.

- Maintaining primary cooling system pressure by LHSI

In case of resumption of natural circulation after reaching the LHSI injection threshold, the pressure would stabilise at the LHSI delivery pressure. Maintaining pressure by LHSI can have several penalising effects with respect to the hot shock, more specifically the maintaining of the high saturation temperature and a reduction in the safety injection flow rate in the primary cooling system. These two phenomena have direct effects on the mixing temperature inducing the hot shock. Furthermore, maintaining pressure in the primary cooling system leads to an increase in mechanical stresses.

Questioned on this point, Areva NP indicated [58] that the primary coolant temperature at the SG outlet is forcibly equal to (or slight higher than) the temperature of the secondary cooling system despite the possible maintaining of pressure by the LHSI: in this case this temperature would become under-saturated. The rapporteur considers the argument provided by Areva NP to be acceptable. Furthermore, maintaining pressure takes place while the pressuriser is filling up. Resumption of natural circulation will take place once the primary coolant system reaches a single-phase state. The natural circulation flow will therefore resume on the reactor in single-phase state at about 200 kg/s instead of the 500 kg/s currently used in the characterisation file. Resumption of natural circulation with a lower flow rate is beneficial for the mixing temperature and covers the penalising effect of possible maintaining of primary cooling system pressure by the LHSI. To conclude, this study is not called into question by the fact that maintaining pressure in the primary cooling system by the LHSI system is not taken into account. **The rapporteur has no other comments to make on this point.**

- Reduction of the RCN flow rate

Questioned on the justification for the chosen RCN flow rate profile (see Figure A6), Areva NP provided the elements which are detailed in notice [59]. It first gave a recap of the main physical phenomena governing resumption of natural circulation (Figure A8). Areva NP the used the results of the PKL III test as a basis for defining an approach allowing verification of the conservative nature of the RCN flow rate considered for the hot shock analysis, and in particular the flow rate peak value and duration. On the basis of these observations, Areva NP modified the flow rate profile and adopted the following profile (Figure A9):

- a rapid rise in flow rate to a given value (maximum flow rate of 500 kg/s);
- a constant plateau at this value for a period corresponding to the time it takes for the water volumes of the core, the upper plenum and the hot leg to be swept by the two-phase flow in question;
- a sudden drop in the flow rate down to the single-phase natural circulation value (200 kg/s).

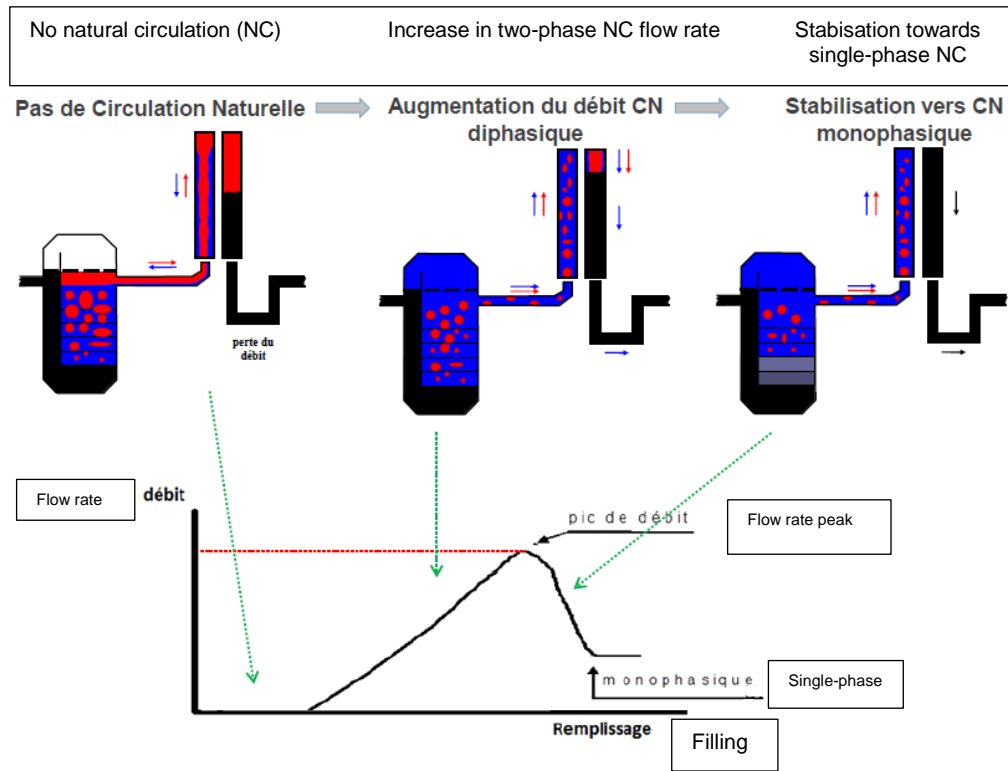

Figure A8: Mechanism of natural circulation resumption (RCN) further to a LOCA 0

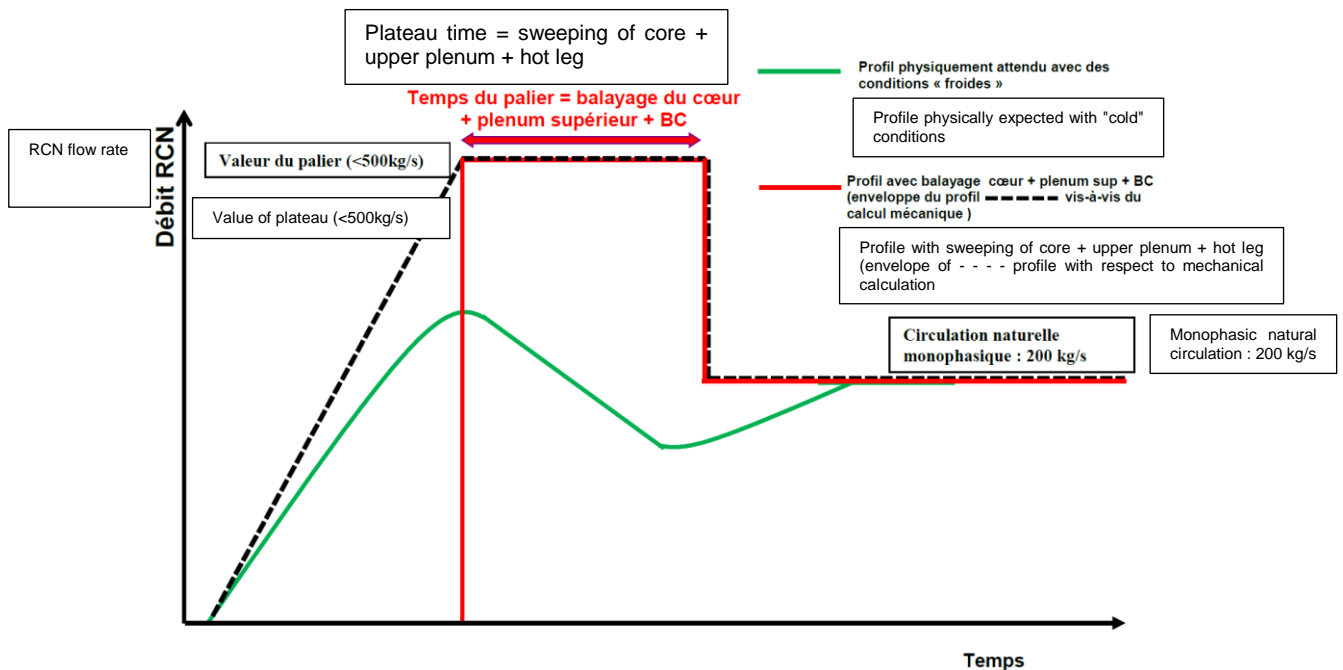

Figure A9 : "Envelope RCN" flow rate profiles for the hot shock calculations[44]

The plateau duration is variable as it depends on the RCN flow rate considered. Several RCN flow rate / plateau duration combinations can therefore be envisaged. A high flow rate leads to a reduction in the sweeping time and an increase in the mixing temperature; it is therefore not easy to define the flow rate/plateau duration combination that penalises the hot shock on the lower dome. Areva NP therefore conducted sensitivity studies to evaluate the impact of the chosen flow rate profile. **The worst-case situation is obtained with a maximum flow rate of 300 kg/s and an initial RPV temperature of 30°C.**

In its evaluation, Areva NP considered that the sweeping of the core and upper plenum volumes

by the RCN flow is sufficient to guarantee reduction of the flow rate to a value of 200 kg/s (single-phase flow rate). Hot leg sweeping is also taken into consideration in order to have a conservative evaluation. The rapporteur considers this approach acceptable but underlines that the two-phase plateau duration should also depend on the residual power. This is because if the flow entering the core at a given temperature does not enable the residual power to be evacuated from the core in single-phase liquid state, the natural circulation flow rate will necessarily be maintained at a high value corresponding to a two-phase flow associated with the formation of steam at the core outlet. The rapporteur carried out an evaluation which confirmed that the residual power of the reactor can be evacuated in single-phase liquid state, and this with several RCN flow rate values and considering two IS trains injecting water at a temperature of 15°C. **Consequently the rapporteur considers that the flow rate profile chosen by Areva NP is acceptable.**

- Number of loops concerned by the simultaneous resumption of natural circulation (entrainment of two water plugs)

Areva NP considers that the resumption of natural circulation takes place in a single loop in a loss of primary coolant accident (LOCA) scenario involving a small break classified in category 3. Areva NP considers the resumption of natural circulation in two loops (and therefore the entrainment of two hot plugs) unlikely, therefore it considers that this situation should at least be classified in category 4. Moreover, Areva NP points out the fact that, during the PKL tests, it was never possible to create conditions causing simultaneous entrainment of two plugs. In this respect, the rapporteur points out [63] the very small number of tests available (E1.1, E2.2 and F1.1) and the strong reservations with regard to the representativeness of the PKL loop (as much in terms of geometry as test conditions), particularly with respect to the resumption of natural circulation. As a consequence, the rapporteur considers that the absence of simultaneous resumption of natural circulation in two loops in the PKL tests is not sufficient ground to rule out this case on the EPR reactor, nor does it justify classifying this scenario in category 4.

Thus, at the request of the rapporteur, Areva NP provided a characterisation of this situation corresponding to resumption of natural circulation in two loops with two safety injection chains in service, which it proposes analysing in category 3. The rapporteur considers this characterisation acceptable.

Conservatism of the approach

Areva NP considered [66] that the thermohydraulic profile associated with this scenario is conservative, given its construction and the associated assumptions. The approach uses uncoupling by first maximising the cold shock on the RPV, then maximising the hot shock that follows. Thus, during the phase of loss of natural circulation, RPV cooling is considered to be maximal (corresponding to a hot leg break with four IS trains in service at the maximum unit flow rate), and during the resumption of natural circulation, the temperature considered for the hot shock is maximal (corresponding to a cold leg break with only two IS trains in service operating at the minimum unit flow rate). Areva NP underlines the fact that the chosen uncoupling assumes that resumption of natural circulation can occur at any moment during the transient, independently of the coherence between the IS flow rate, the flow rate at the break and the residual power. The rapporteur agrees that this uncoupled transient is of a conservative nature which allows a large number of configurations to be covered (according to the size and position of the break, the number and characteristics of the systems, the residual power, etc.) and the worst-case configuration to be identified.

To conclude, the rapporteur considers that the characterisation of this situation is acceptable.

c) Hot shock transient No. 3 not considered in the DDS: Loss of cooling by the RIS-RA in RA mode initiated in C state (category 4)

Loss of cooling by the RIS-RA in RA mode can be initiated when the RIS-RA is connected to the primary cooling system in RA mode from C state (normal shutdown on RIS-RA in RA mode). This leads to heating of the primary coolant fluid due to the residual power and the power transferred to the primary coolant fluid by the MCCPs in service. The coolant fluid temperature increases until it reaches the saturation temperature of the available SGs. Furthermore, due to the expansion of the primary coolant, the primary coolant pressure increases with the potential of reaching the cold pressure setting of the pressuriser safety valves⁶⁷.

Several variants of this scenario are studied according to the number of reactor coolant pumps in service and the initial state of the reactor (state C2 or C3⁶⁸). The worst-case situation identified by Areva NP is an initial C3 state without the MCCPs. This leads to heating from 15°C (minimum temperature in C3 state) to 155°C (maximum temperature corresponding to the SG saturation temperature at the opening pressure of the atmospheric steam dump valves) with a gradient of 415 °C/h and a pressure of 68.5 bar (pressure setting of the first pressuriser valve increased by its uncertainty and the weight of the column of water). The exchange coefficient used is a constant envelope value that encompasses heat exchange by natural convection.

The rapporteur notes that Areva NP studies two restrictive situations of loss of the four LHSI/RA chains with respect to the risk of fast fracture of the lower and upper domes in its initial file [47]. These are situations initiated during C2 state, a state in which the temperature is reduced from 100°C to 50°C by the entry into service of the four LHSI/RA trains, with one or two MCCPs in service.

During the examination [48], the rapporteur considered that Areva NP should analyse the case of total loss of the RIS-RA in C3 state without MCCPs in order to verify the appropriateness of the envelope case considered for this situation. This is because in C3 state the temperature is maintained below 55°C and the MCCPs are shut down. In this respect, Areva NP indicates [47] that loss of the LHSI/RA trains in C3 state would be less penalising than in C2 state due to the lower residual power and shutdown of the MCCPs. The rapporteur agrees that these favourable effects exist but underlines that the initial temperature is lower, which is penalising. Moreover, the fluid volume to consider should be lower in C3 state due to the absence of forced circulation in the RPV, therefore the heating kinetics could be faster. In addition, the heat exchange with the walls is reduced when flow rates are low.

⁶⁷ Nominal opening pressures of the valves modified (64, 67 and 70 bar absolute) following activation of the low-temperature overpressure protection system as soon as the cold leg temperature is less than or equal to 120°C.

⁶⁸ Sub-states of state C, intermediate shutdown on the RIS-RA system in RA mode. In state C2, the temperature is reduced from 100°C to 50°C by entry into service of the four ISBP/RA trains, with one or two MCCPs in service. In state C3, the temperature is maintained below 55°C and the MCCPs are shutdown.

In response, Areva NP supplemented its case file with the study of two additional cases in C3 state: one with the MCCPs shut down and one with the four MCCPs in service with a view to restarting the plant unit. The analysis of these two additional cases revealed a new and more penalising scenario corresponding to total loss of the RIS-RA in C3 state without the MCCPs. The characterisation of the new penalising case (RIS-RA in C3 state without MCCPs) is presented in [49]. It involves a hot shock from 15°C to 155°C taking a heating rate of 415°C/h and a constant pressure equal to the conservative opening pressure of the first pressuriser safety valve.

The chosen heating rate [49] takes into account the residual power eight hours after rod drop (entry into C3 state), increased by its uncertainty and limiting the volume of primary coolant to the volume of water in the core and the upper plenum, insofar as the MCCPs are shut down. In addition, conservatively, neither the metal masses nor the volume of water in the dome are taken into account in this calculation. Moreover, as the MCCPs are shut down, a constant exchange coefficient that is conservative with respect to heat exchange by natural convection is used. In order to take into account the uncertainties concerning the correlation used, the exchange coefficient is multiplied by a factor of 2, as requested by the rapporteur.

In addition, Areva NP listed a number of conservatisms in the description of this situation [43]. The initial temperature considered in this study is the minimum temperature attained at the end of C3 state when the residual power is taken as being maximal, corresponding to the start of C3 state. Areva NP considers that this approach is conservative and enables the number of studied configurations to be limited. The metallic masses of the RPV internals are not taken into account, which could reduce the calculated heating rates by about 100°C/h. Lastly, the upper dome temperature is taken as being 15°C over the entire thickness, whereas the last pump stopped when the temperature reached 55°C: as all the MCCPs are shut down, cooling of the upper dome is limited (the density effect opposes cooling of the dome). The value of the initial upper dome temperature therefore constitutes a significant conservative factor.

After analysis, the rapporteur considers that the chosen assumptions are conservative and enable a conservative characterisation to be defined for the category-4 transient involving loss of cooling by the RIS-RA in RA mode initiated in state C.

Appendix 6: Thermomechanical loadings - Exhaustiveness and characterisation of the category-3 and category-4 cold shock thermohydraulic transients

In this appendix the rapporteur presents the worst-case category-3 and -4 cold shock situations and their characterisations, followed by an analysis of their exhaustiveness and pertinence.

Exhaustiveness of the worst-case cold shock situations

With regard to the category-3 and category-4 situations, Areva NP supplemented the initial list of cold shock situations of the DDS during the examination by adding the transient involving rod ejection further to fracture of a casing which would cause a loss of coolant accident at the upper dome then potentially a cold shock further to activation of safety injection. Following this addition, the rapporteur asked Areva to substantiate the exhaustiveness of the chosen situations.

Areva NP indicated in [56] that the worst-case transients to consider are those involving rapid and large-amplitude cooling of the fluid followed by a holding period at the temperature reached, combined with high pressure.

For the RPV lower dome, the transients used are those presented in the DDS which penalise the arrival of cold water and maintaining under pressure. This is because the characterisation of these situations is made more severe to check the mechanical strength of the most sensitive zones of the primary cooling system (independently of the carbon segregation), that is to say the inlet and outlet nozzles and the core shells for the reactor pressure vessel. Consequently, these situations are also more severe for the RPV lower dome. **The rapporteur considers that these choices are effectively penalising for the lower dome and that the situations adopted for the core zone are also pertinent for the RPV lower head.**

Areva NP conducted analysis to identify the cold shock situations that are more severe for the RPV upper dome. This analysis comprises two phases:

- the first phase consists in identifying the physical phenomena that lead to a rapid reduction in the temperature of the fluid in the RPV dome to a temperature below 100°C, associated with a high pressure;
- the second phase consists in identifying the transients during which the physical phenomena characterised in the first phase occur.

The rapporteur considers this analysis, which is of the same type as that used to check the exhaustiveness of the worst-case hot shocks, is satisfactory.

More generally, the rapporteur asked how, for the Flamanville EPR reactor, Areva NP took into account the experience feedback from the examinations relative to the in-service behaviour of the 900 and 1300 MWe RPVs with regard to the exhaustiveness of the cold shock transients. For information, a process for selecting transients in addition to those of the DDS was initiated as part of the examination of the RPV in-service behaviour files (focusing on the irradiated vessel shell rings of the core zone) on the reactors in operation to verify the exhaustiveness of the DDS and check the conservative nature of the situations in each of the categories. This process consists in adding failures that induce unfavourable cold shock situations to the category-2 and 3 situations, then check whether the characterisation of the transients associated with the current situations in the DDS effectively cover these new transients. The study of these additional transients falls within the scope of the design verification. It therefore complements the design-

basis file itself. Areva NP indicated in [60] that this process, which is currently being applied to the fleet, has so far identified no transients more severe than those in the DDS. For the Flamanville EPR reactor, Areva NP indicated in [60] that from its first analysis it has not identified any situation whose characterisation is not covered by that of the current situations in the DDS.

Lastly, the rapporteur observes that the list of situations in the DDS for the Flamanville EPR reactor covers the list of operating conditions of the safety analysis report (SAR), and in particular the operating conditions of the complementary range (situations called "RRC-A" - Risk Residual Category - on the EPR reactor). Thus, the Flamanville EPR reactor DDS integrates situations with operation under maximum cooling by the secondary cooling system, situations with implementation of feed-and-bleed operation⁶⁹, the situation of loss of coolant accident without safety injection and the situation of fracture of two steam lines assumed to be induced by an external event (plane crash). The rapporteur considers that these complementary situations have been taken into account satisfactorily.

Characterisation of category-4 cold shock situations

- Rod ejection (EDG)

This situation corresponds to the fracture of a rod cluster control assembly (RCCA) casing (see Figure A10), which causes its ejection and creates a primary system break with a maximum cross-sectional area of 45 cm² located in the RPV closure head. In the course of this situation, due to the location of the break, the cold water injected by the safety injection system will be fed rapidly and constantly to the dome, causing a significant cold shock, particularly at the upper dome. This is the worst-case category-4 cold shock situation for the upper dome, which is not analysed in the DDS and whose characterisation is given in notice [55]. This characterisation is obtained by means of the CATHARE software which uses a simplified model to represent the volume under the RPV closure head. Areva NP adopted a mean temperature, calculated with this software, at the RCCA guide exit to characterise the temperature of the fluid at the upper dome.

⁶⁹ "Bleed and feed" operation allows the evacuation of the residual power by opening the pressurise valves and injecting cold water into the core via the safety injection system.

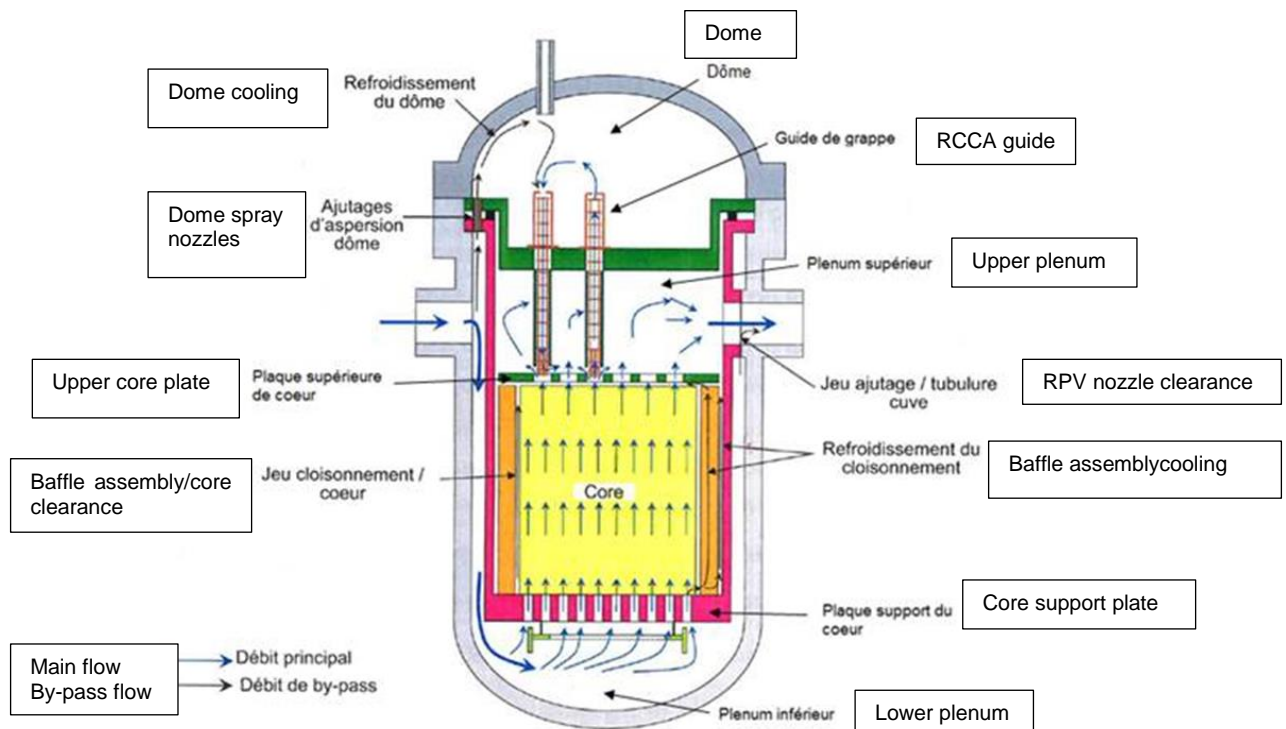

Figure A10 : Core main flow and by-pass flow in normal operation

The rapporteur does however consider that the opening of a break by fracture of a control rod drive mechanism housing under pressure can lead to a highly asymmetrical flow field in the upper part of the RPV and that it is not guaranteed that the mean temperature at the exit from the RCCA guides constitutes a conservative value of the fluid temperature at the upper dome. This is because the break may be supplied preferentially by the cold fluid from the guide tubes of the assembly situated directly underneath the fractured housing and by the flow from the spray nozzles.

In this respect, Areva NP estimated in [65] that the flow entering the dome from the RCCA guides cannot come directly from the lower plenum (PI), more specifically because there is no direct fluid path between this plenum and the dome as the guide tubes exit upstream of the upper core plate (PSC) at the level of the top fuel assembly nozzles. Furthermore, Areva NP pointed out that the flow in the guide tubes represents just a few percent of the flow circulating in the core, even when the reactor main coolant circulation pumps (MCCP) are shut down.

The rapporteur observes that Areva NP's arguments do not take into account the effects of rod ejection on the flow towards the dome. This argument more particularly does not take account of the large increase in the flow cross-section in the guide tube of the assembly concerned, which causes a reduction in the temperature of the water entering the dome. On the other hand, the rapporteur conservatively estimates this reduction in temperature at just a few degrees, which it does not consider significant. **The rapporteur has no other comments to make on the characterisation of this situation.**

- Category-4 cold overpressure break on the RIS-RA system in RA mode

This situation initially causes a cold shock due to the injection of cold water by the safety injection system, then an overpressure situation when the operator isolates the break. At the request of the rapporteur, Areva NP characterised this situation which is not identified in the DDS and assessed its effect on the lower dome in a category-4 situation by using an exchange

coefficient that varied according to the flow rate [57]. Areva NP considers that the upper dome is not concerned by this situation due to the stopping of fluid circulation after shutting down the reactor coolant pumps. The rapporteur considers that the characterisation proposed by Areva NP, assuming an instantaneous cold shock of 124°C associated with a primary system pressure of 74.5 bars (pressure setting of the pressuriser safety valves in C-state) is conservative.

The rapporteur however noted that Areva NP considers that, despite a much greater cold shock, this situation creates less of a load stress than the category-4 cold overpressure situation associated with the inadvertent starting of safety injection studied in the DDS.

It turned out that this was due to the fact that Areva NP used a variable exchange coefficient for this situation whereas in the situation studied in the DDS, an infinite exchange coefficient is used in an uncoupled manner. In this respect the rapporteur pointed out that the flow velocity of the fluid used to calculate the exchange coefficient in forced convection is underestimated (see Appendix 4). Areva NP therefore evaluated the consequences with an infinite exchange coefficient. **The rapporteur has no further comments on the thus-modified characterisation of this situation, which becomes the worst-case category-4 cold shock situation for the lower dome.**

The rapporteur does however consider that this transient can also cause loading of the upper dome due to the potential phenomena of emptying and filling the dome with the cold water from the safety injection. At the end of the examination, Areva NP provided elements showing that an instantaneous cold shock from 320°C to 40°C associated with an infinite fluid-wall exchange coefficient is not harmful for the RPV upper dome. **The rapporteur considers this characterisation to be sufficient.**

- Category-4 cold overpressure from inadvertent opening of an RRA valve with MCCP shutdown then return to service

Inadvertent opening of an RRA valve causes a cold shock and shutdown of the reactor coolant pumps. In the event of inadvertent restarting of one of the pumps, the cold water will heat up when it passes through the SG, which will cause overpressure due to expansion. This is the worst-case category-4 cold overpressure situation for the reactors in service, but it is not studied for the Flamanville EPR reactor. Areva NP considers in [53] that it is covered by the situation involving a break in the RIS-RA system in RA mode. Effectively, on the reactors in service this situation causes a cold shock of 160°C in 30 minutes at 30 bar to be compared with an instantaneous cold shock of 124°C with a primary system pressure of 74.5 bar in the case of a break in the RIS-RA system of the Flamanville EPR reactor. **The rapporteur considers Areva NP's arguments to be acceptable and has no further comments to make on this situation.**

- Situation of : inadvertent opening then closing of a pressuriser safety valve

The situation of inadvertent opening of a pressuriser safety valve studied in the DDS in category 3 causes a cold shock further to safety injection. Nevertheless, the combining of valve opening with its inadvertent closing, which would cause cold overpressure, is not studied. For information, this situation appears in the list of potentially penalising transients identified by international studies [64].

Further to the request of the rapporteur, Areva NP provided the analysis of this situation in [52] and arguments substantiating the classifying of this situation in category 4.

The rapporteur observes that this is not the worst-case transient even if this situation was classified in category 3 and has no further requests concerning this point for the lower dome.

With regard to the upper dome, this situation causes emptying then filling of the dome for which the characterisation was consolidated at the end of the examination. The rapporteur considers that the characterisation of this situation finally adopted by Areva NP is penalising.

Appendix 7: RPV dome replacement scenarios

This appendix presents the RPV replacement scenarios studied by Areva NP and EDF. The scenarios are not examined in this report.

Reminder of requests made by ASN further to the sessions of the GP ESPN of Experts of 30th September 2015 and 24th June 2016

In its letter reference [7], ASN informed Areva NP that under article 9 of the NPE order in reference [3], an NPE commissioning application that does not meet all the regulatory requirements must be justified with respect to the advantages and drawbacks of the alternative solutions. More specifically, given the safety issues associated with the Flamanville EPR reactor pressure vessel and without prejudice to the results of the tests performed by Areva NP, ASN considered it necessary to study technical scenarios for the repair or replacement of the RPV.

Requests to this effect were sent to Areva by ASN in letter reference [7]:

"ASN requests, without prejudice to the results of the future mechanical tests campaign, that you study as from now the manufacture of a new RPV closure head taking into account experience feedback from the design and manufacture of the current head."

"ASN requests that you conduct, in relation with the licensee, a technical study of the scenarios for extracting the reactor pressure vessel body from the reactor building pit and replacing the RPV lower dome. This study must analyse the advantages and drawbacks in terms of the quality of the work done and the safety of the facility."

Elements provided by Areva NP

Replacement of the RPV closure head

In document reference [15], Areva NP has studied the scenario for replacement of the RPV closure head intended for the Flamanville EPR reactor. In this scenario, the manufacturer studied the design, procurement and manufacturing phases and the on-site replacement operations. For each phase, the manufacturer estimated the duration of the operations.

During the examination of the design phase, the manufacturer questioned itself about the design of the RPV closure head adaptor installation welds shown in Figure A11. With their current design, these welds are difficult to produce because of the shape and the nature of the materials to assemble (Inconel 690 alloy weld), and it is impossible to perform an NDT (non-destructive testing) inspection of their entire volume. The initial welds of the RPV closure head for the Flamanville EPR reactor have thus all been reworked further to these difficulties. The rework conditions were presented to the Advisory Committee for Nuclear Pressure Equipment (GP ESPN) at its session of 14th September 2011.

Further to its analysis, Areva NP considers that it is impossible to design a closure head in which the entire volume of the welds can be inspected, but that improvements can be made, as much in the inspections (improvements based on multi-element ultrasound transducers) as in the production of the weld itself (machining a recess at the root of the weld).

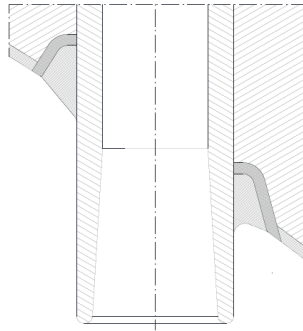

Figure A11 : Current design of the reactor pressure vessel closure head adapters

With regard to the procurement of the closure head component (dome and flange), the manufacturer is considering consulting the Japanese company Japan Steel Works (JSW). These two components would be procured complying with the technical qualification requirement of the NPE order in reference [3] in order to demonstrate control of the risk of heterogeneity and ensure that the required characteristics are attained. Areva NP considers that the knowledge acquired by JSW and its ability to control the heterogeneity risks will provide a guarantee that the part will be free of prejudicial carbon positive macro-segregation.

By adopting this design and procurement scenario and integrating the duration of the manufacturing operations (assembly of the flange on the dome, cladding the components and welding the reactor pressure vessel head adapters), Areva NP's estimated time frame for on-site delivery of an unequipped closure head is 71 months. The closure head must then be equipped with the control rod drive mechanisms (CRDM), the core instrumentation and an integrated lifting assembly for handling.

According to Areva NP, replacement of the closure head during a reactor outage for maintenance will necessitate the following operations:

- disassembly of the closure head in the reactor building, in parallel with reception and pre-equipping of the new closure head;
- removal of the old closure head from the reactor building;
- introduction of the new pre-equipped closure head into the reactor building;
- finalising of the equipping of the new closure head and installation on the reactor pressure vessel.

Areva NP estimates the duration of these on-site operations to be 4 to 9 months depending on the work organisation hypotheses considered (2x8h or 3x8h, 7 days a week). This time frame can be reduced if new control rod drive mechanisms (CRDM) are procured and installed on the new closure cover on site before introducing it into the reactor building. Areva NP does however point out that the new closure cover thus equipped will have to be introduced into the reactor building in the vertical position and the feasibility of such an operation still has to be confirmed by a detailed analysis.

To conclude, Areva NP gives a total time frame of 75 to 80 months for the procurement, manufacture and installation of a new closure cover on the Flamanville EPR reactor pressure vessel. Areva NP considers that this replacement scenario should preferably be implemented during the first 10-yearly outage of the reactor.

Removal of the reactor pressure vessel body and replacement of the RPV lower head

In the document reference [16], Areva NP has examined the scenario for replacing the Flamanville EPR RPV lower head. The manufacturer has adopted the principles of using known tried and tested procedures, and at the end of the operation to return the reactor in a configuration that is as close as possible to the initial state. Moreover, the manufacturer considers that the dome replacement operation in itself cannot be carried out on the Flamanville site and will necessitate transporting the RPV to the manufacturing shops for questions of environment and availability of tools.

The scenario adopted by Areva NP involves separating the RPV from the primary cooling system, extracting the RPV to ship it to the manufacturer's shops, replacing the RPV lower head in the shop, reinstalling the RPV in the reactor pit and welding it to the main primary cooling system. This scenario led to an examination of the impacts on the civil engineering of the buildings and on the nuclear pressure equipment of the main primary cooling system (Figure A12).

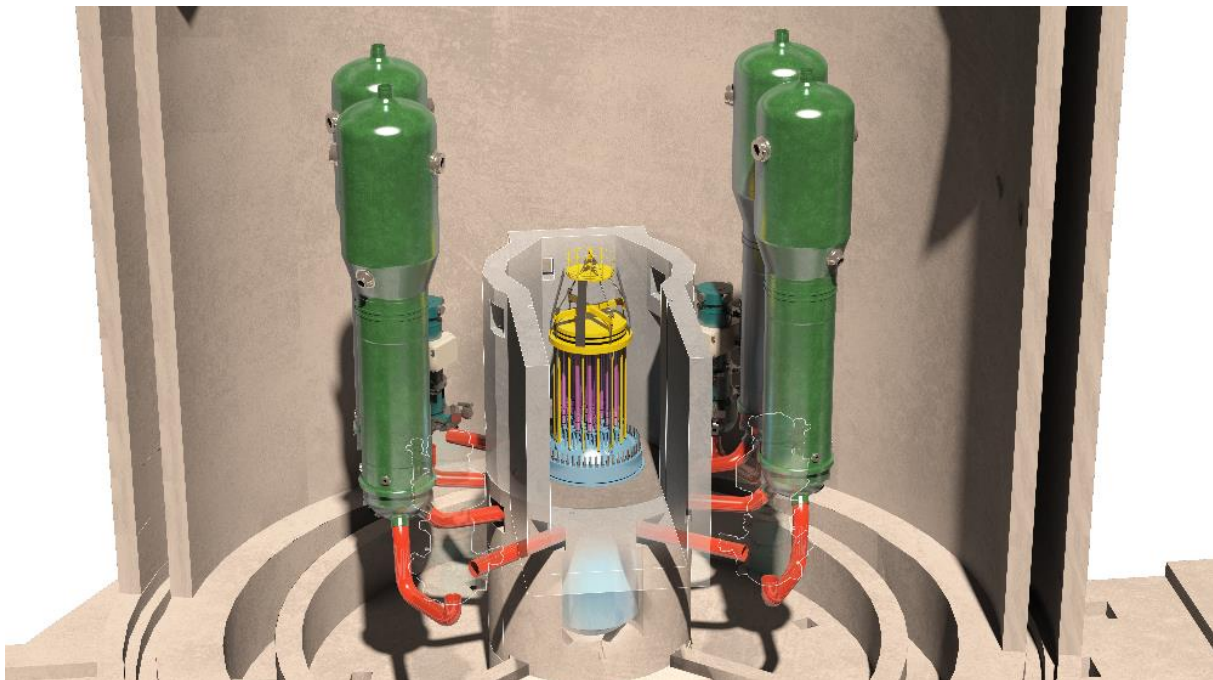

Figure A12 : The reactor pressure vessel (RPV) in the reactor building

In notice reference [77], EDF has summarised the main civil engineering impacts of extracting and reintroducing the RPV into its initial position. These impacts concern:

- external interfaces between the handling gantry and the boron disposal room;
- the creation of an opening from the gantry situated on the exterior in the west wall of the handling tower. It should be noted that this opening will be necessary if the steam generators are replaced in the course of operation;
- verification that the free area of the equipment access hatch is sufficient;
- the removal and storage of walls of the steam generator bunkers and removable slabs of the pool to allow extraction of the RPV;
- reinstallation of the runway track for handling the RPV on the + 19.5 m deck;
- restoring the reactor cavity and the cavity bottom;
- demolition of the limonite ring, a major and delicate operation.

Areva NP indicates in reference document [77] that the choices made for the dismantling of civil engineering structures enable the existing anchors to be kept and thus rebuild identically to the initial construction without having to make structural modifications. Consequently, Areva NP considers that the quality and safety of the installations are ensured for the civil engineering sequence.

The envisaged operations on the nuclear pressure equipment are the cutting of the welds between the RPV and the primary coolant pipes, the handling and transportation of the RPV to the manufacturer's shops, in-shop replacement of the RPV lower head, reintroduction of the RPV and its assembly to the primary coolant pipes.

The welds will have to be cut beyond the bimetallic joints and will result in the shortening of the primary coolant pipes (loss of material and machining of chamfers). The replacement of the RPV lower head dome will lead Areva NP to cut the lower section of the RPV in the zone of connection with the cylindrical core shells (see Figure A13).

Alongside these operations, a new dome and intermediate ring shall be procured and will be assembled before being welded to the RPV. The components will be procured from JSW, complying with the technical qualification requirement of the NPE order reference [3]. More specifically, Areva NP indicates that JSW will be capable of manufacturing a lower head dome that will be free of prejudicial carbon positive macro-segregation.

For these procurement and in-shop assembly operations, Areva NP has not identified any specific risk other than those inherent to a standard manufacturing operation.

On-site assembly of the RPV to the primary coolant pipes will lead the manufacturer to effect a partial replacement of the primary coolant loops (see Figure A14) to compensate for the loss of material during the cutting operations and to have the necessary space to implement NDT inspections. This will therefore lead to the addition of four times two additional welds on the main primary cooling system, which will introduce additional stresses in the loops. These stresses are caused by the welding when closing the primary cooling system which is done on the RPV and not on the steam generators as was the case for the initial assembly. This new configuration will leave the pipes less freedom.

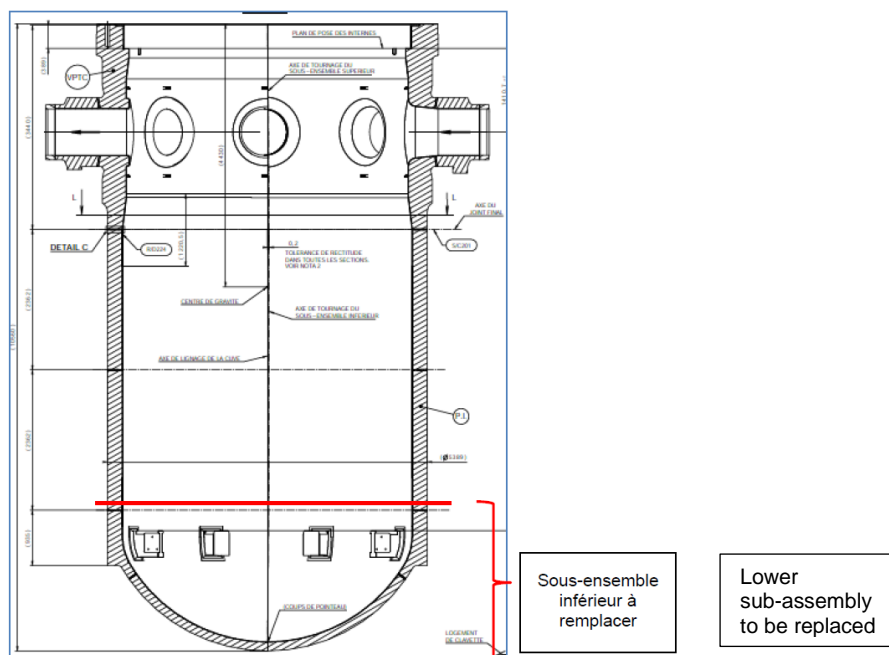

Figure A13 : Cutting the lower section of the RPV in order to replace the dome

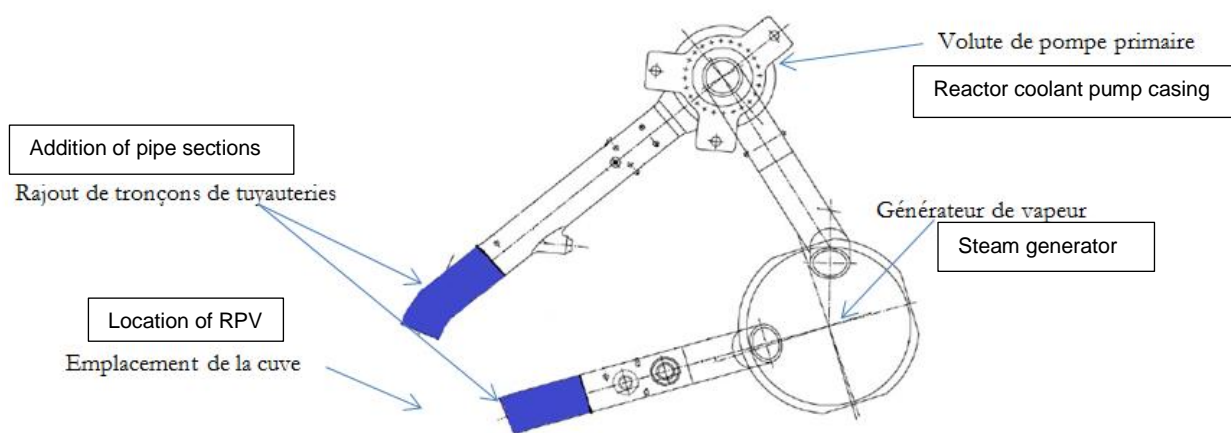

Figure A14 : Top view of a primary cooling system loop indicating the pipe sections to replace

In its document reference [16], Areva NP identified the following risks during its analysis:

- the risk of not being able to keep the RPV internals in the reactor building during the RPV extraction and reinstallation operations;
- the risks associated with the modification of the handling line with requalification of the polar crane and putting back in place the systems of additional trolleys for tipping the component;
- the risk of damaging the RPV during the handling and transportation operations;
- the risk of difficulties in recovering the setting of the lower internals on the radial guides if the even to misalignment with the new lower sub-assembly;
- the risks linked to the large volume of liquid effluents generated by the operations on the civil engineering;
- the risk of additional delays in the procurement of the partial sections of the primary coolant pipes;
- the risks associated with the reconstitution of the primary coolant pipes, as this operation has never been carried out.

The following consequences have been identified:

- shorter stainless endpieces which bring the pipe welds closer to the bimetallic joints, which can limit the repair solutions in order to take inspectability requirements into account;
- the bottom section of the RPV would undergo an additional local stress-relief heat treatment (welded joint between the ring and the dome);
- Areva NP considers that an offset of about 10 mm of the weld between the lower core shell and the connection area will in principle have no impact on the in-service monitoring programme;
- the addition of eight additional welds on the main primary cooling system;
- the addition of additional residual stresses in the primary loops. Mechanical substantiation work will be necessary.

Areva NP considers as a first estimate that the project duration could be 86 months.

Appendix 8: Forging processes for the lower and upper domes of the Flamanville EPR reactor

| Forging process | FA3 RPV lower head dome | FA3 RPV closure head dome |
|------------------------------|-------------------------|---------------------------|
| Ingots | | |
| Blooming | | |
| Upsetting between plates | | |
| Upsetting in parallel passes | | |
| | | |
| | | |
| Machining for hot-forming | | |
| Hot-forming | | |

Hot-forming heating temperature: 1025±50°C

Figure A15 : Forging process for the upper and lower domes of the Flamanville A3 reactor

Appendix 9: Synthesis of the mappings of carbon content at the surface of the domes

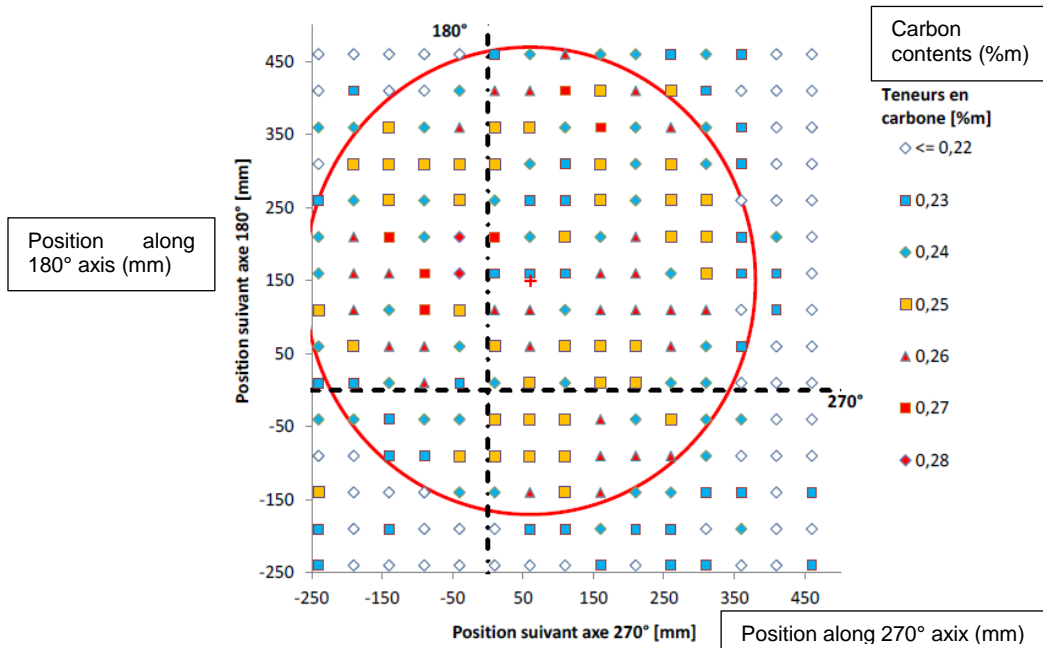

Figure A16 : Illustration of the most segregated zone on external surface of UK upper dome (OES measurements - contractor's device)
Measurement pitch 50 mm x 50 mm

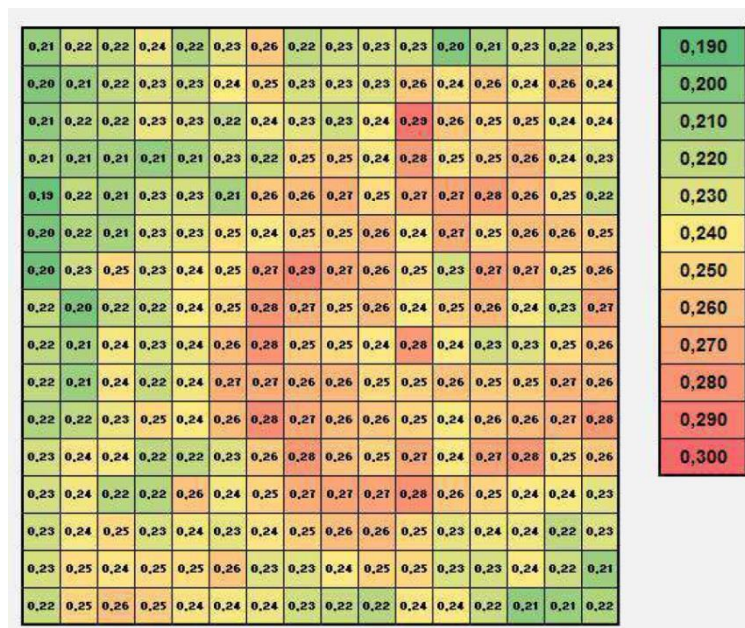

Figure A17 : Illustration of the most segregated zone on external surface of UK upper dome (OES measurements - Areva NP's device)
Measurement pitch 50 mm x 50 mm

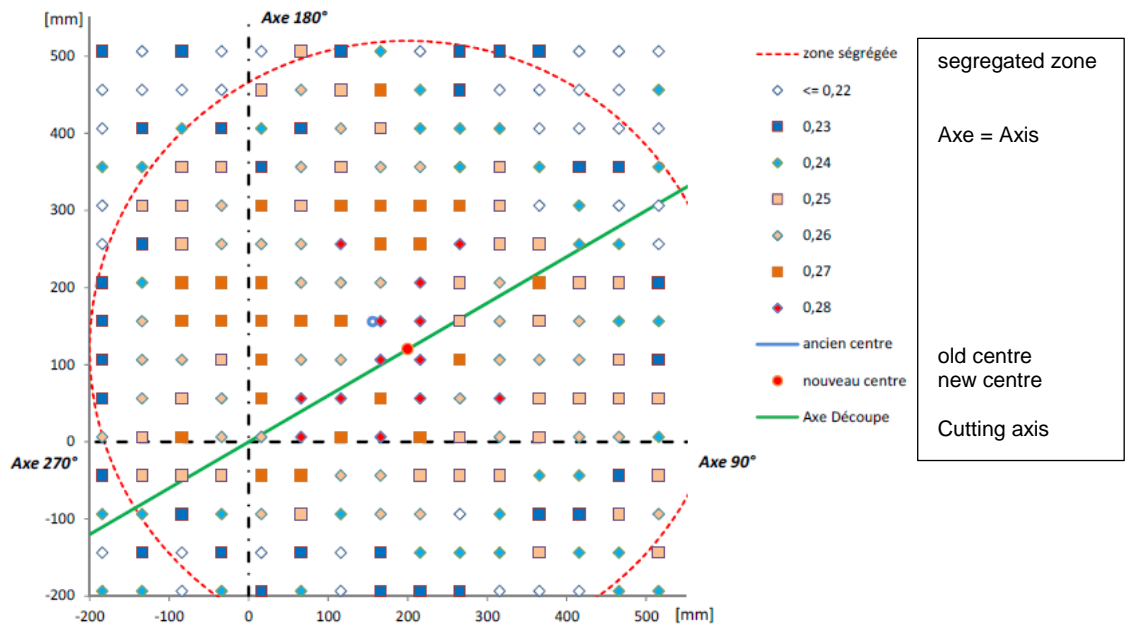

Figure A18 : Illustration of the most segregated zone on external surface of UA lower dome (OES measurements - contractor's device)
Measurement pitch 50 mm x 50 mm

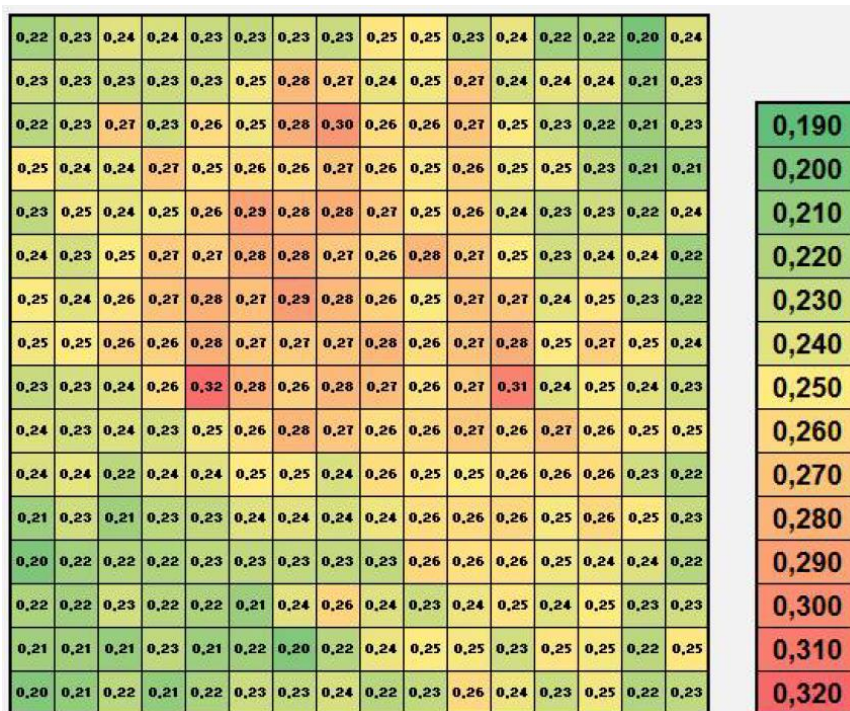

Figure A19 : Illustration of the most segregated zone on external surface of UA lower dome (OES measurements - Areva NPs device)
Measurement pitch 50 mm x 50 mm

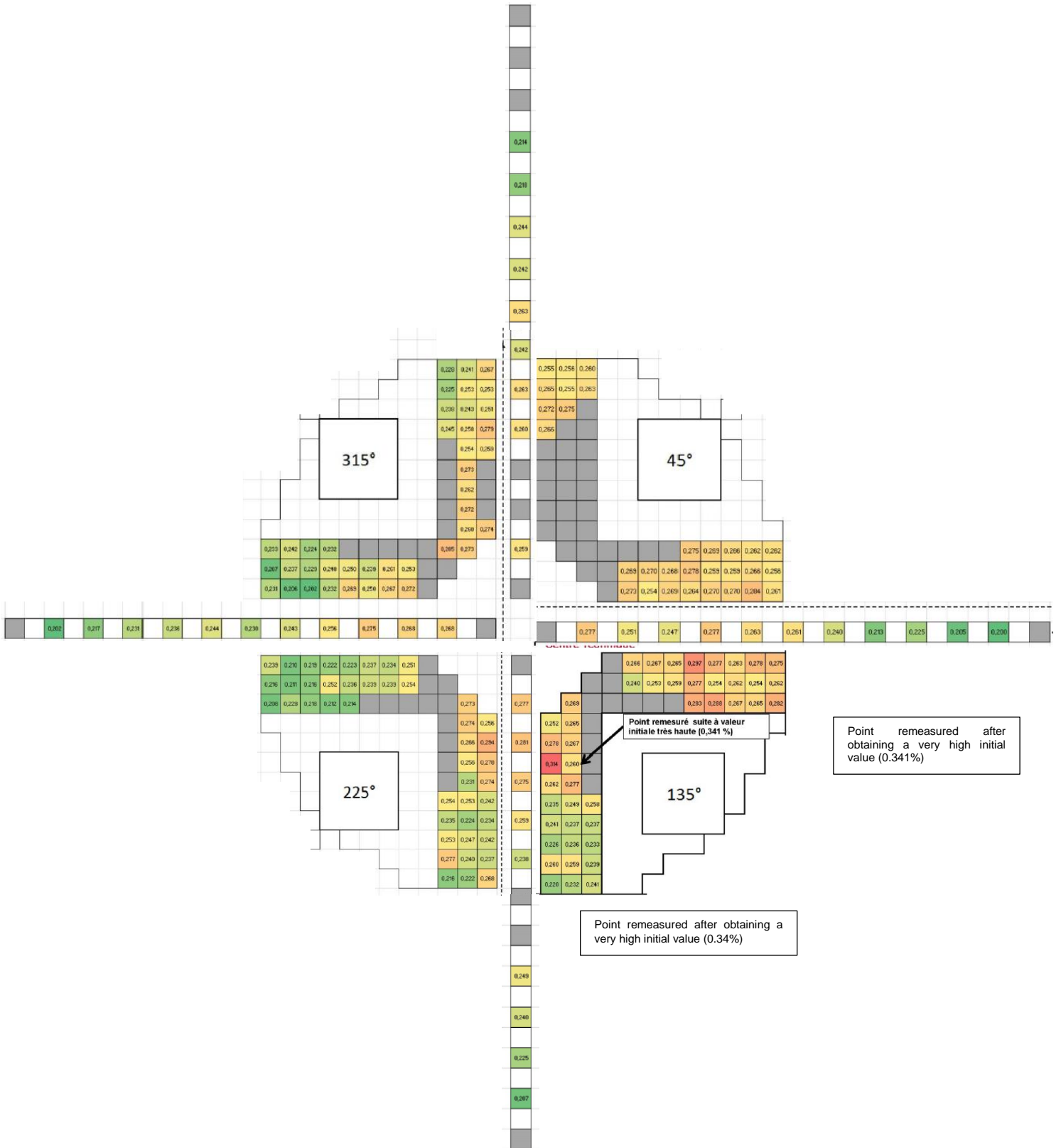

Figure A21. : Illustration of the most segregated zone on external surface of FA3 upper dome (OES measurements - Areva NP's device)
 Measurement pitch 30 mm x 30 mm

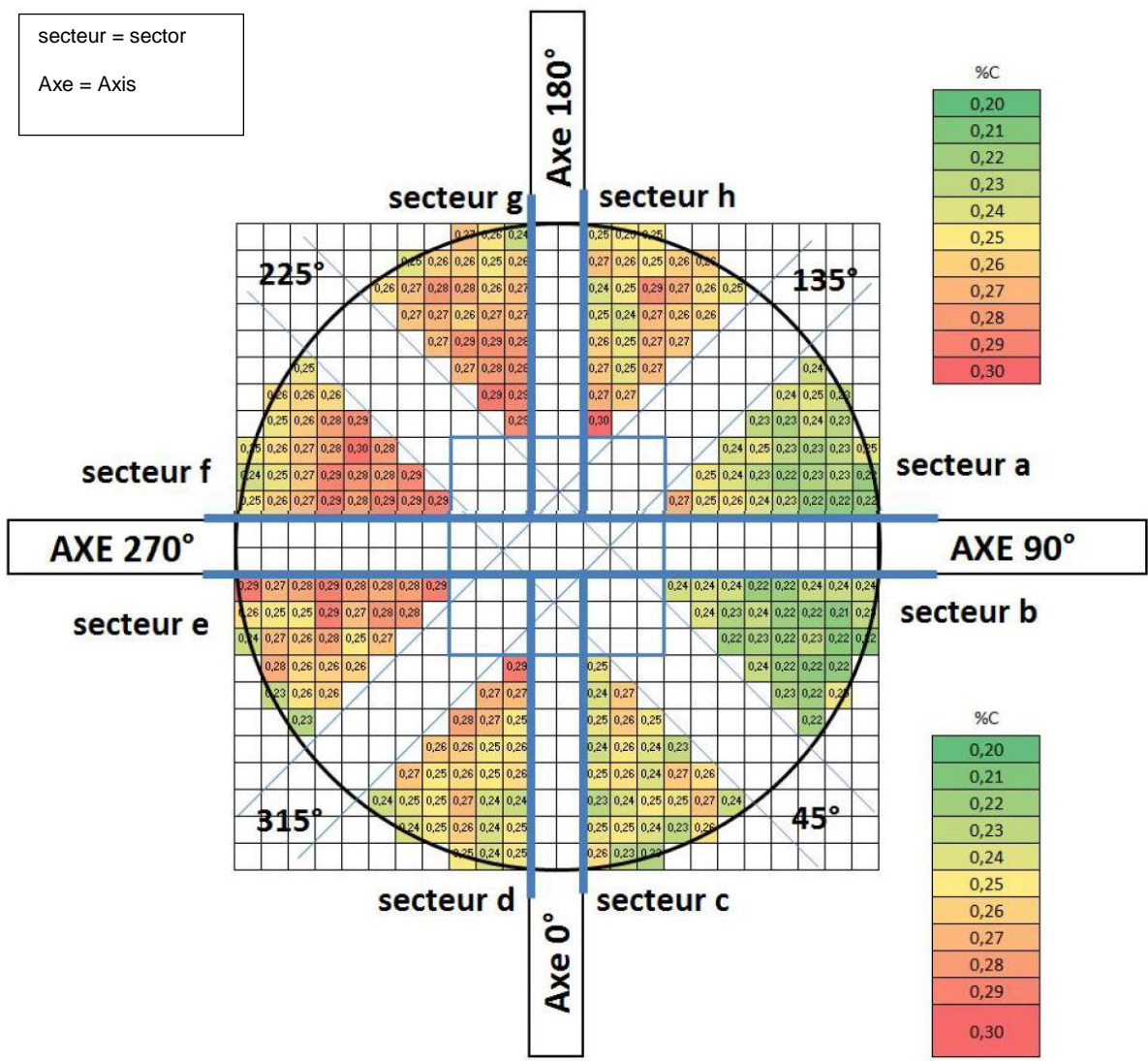

Figure A22. : Illustration of the most segregated zone on external surface of FA3 lower dome (OES measurements - Areva NPs device)
Measurement pitch 30 mm x 30 mm

Appendix 10: Synthesis of carbon content mappings in thickness of domes

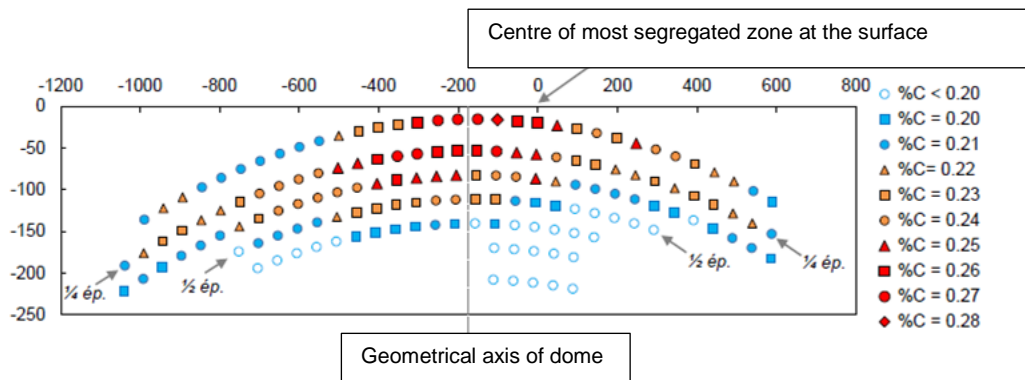

Figure A23. : Carbon content in thickness of UK upper dome
(OES measurements – contractor's device)
Measurement pitch 30 mm x 50 mm
No measurement taken below mid-depth

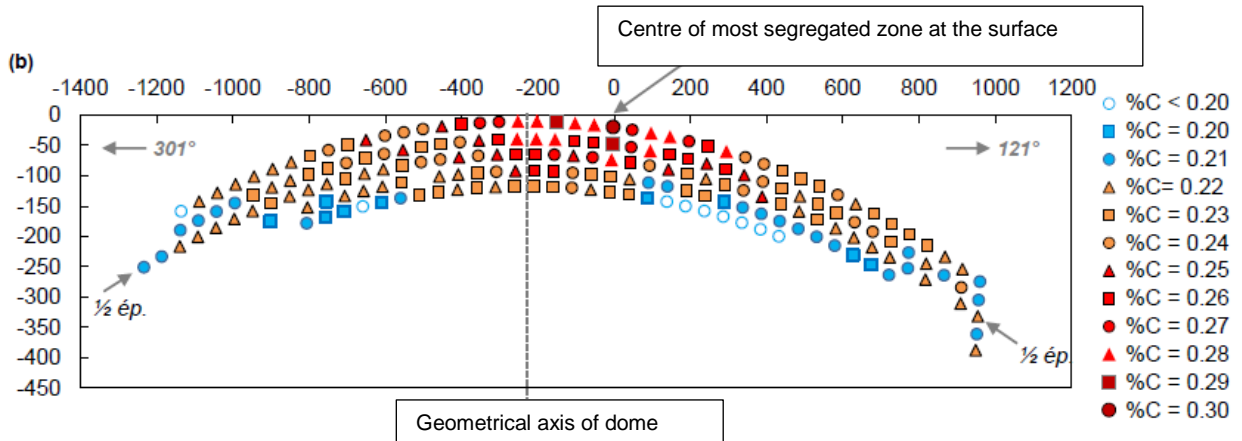

Figure A24. : Carbon content in thickness of UA lower dome
(OES measurements – contractor's device)
Measurement pitch 30 mm x 50 mm
Total thickness illustrated

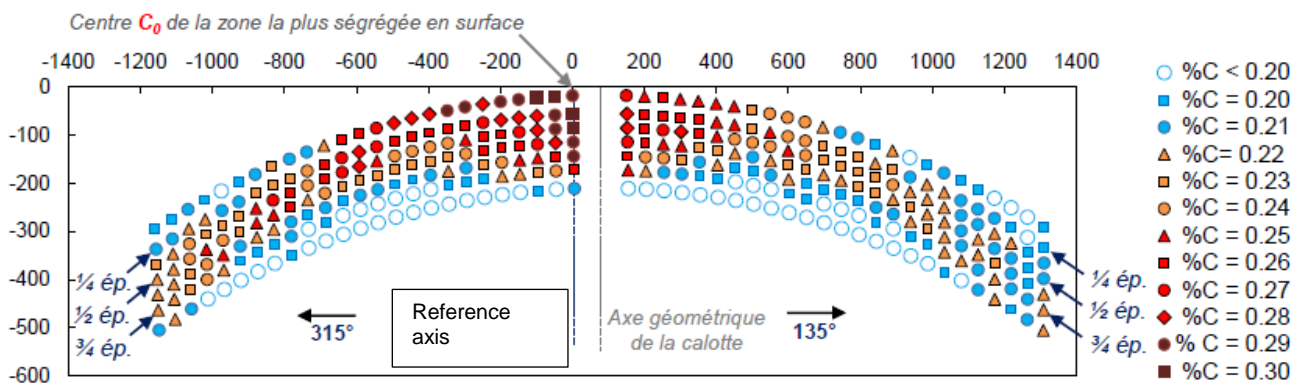

Figure A25. : Carbon content in thickness of UA upper dome
(OES measurements – contractor's device)
Measurement pitch 30 mm x 50 mm
Total thickness illustrated

Appendix 11: Synthesis of carbon content mappings by depth

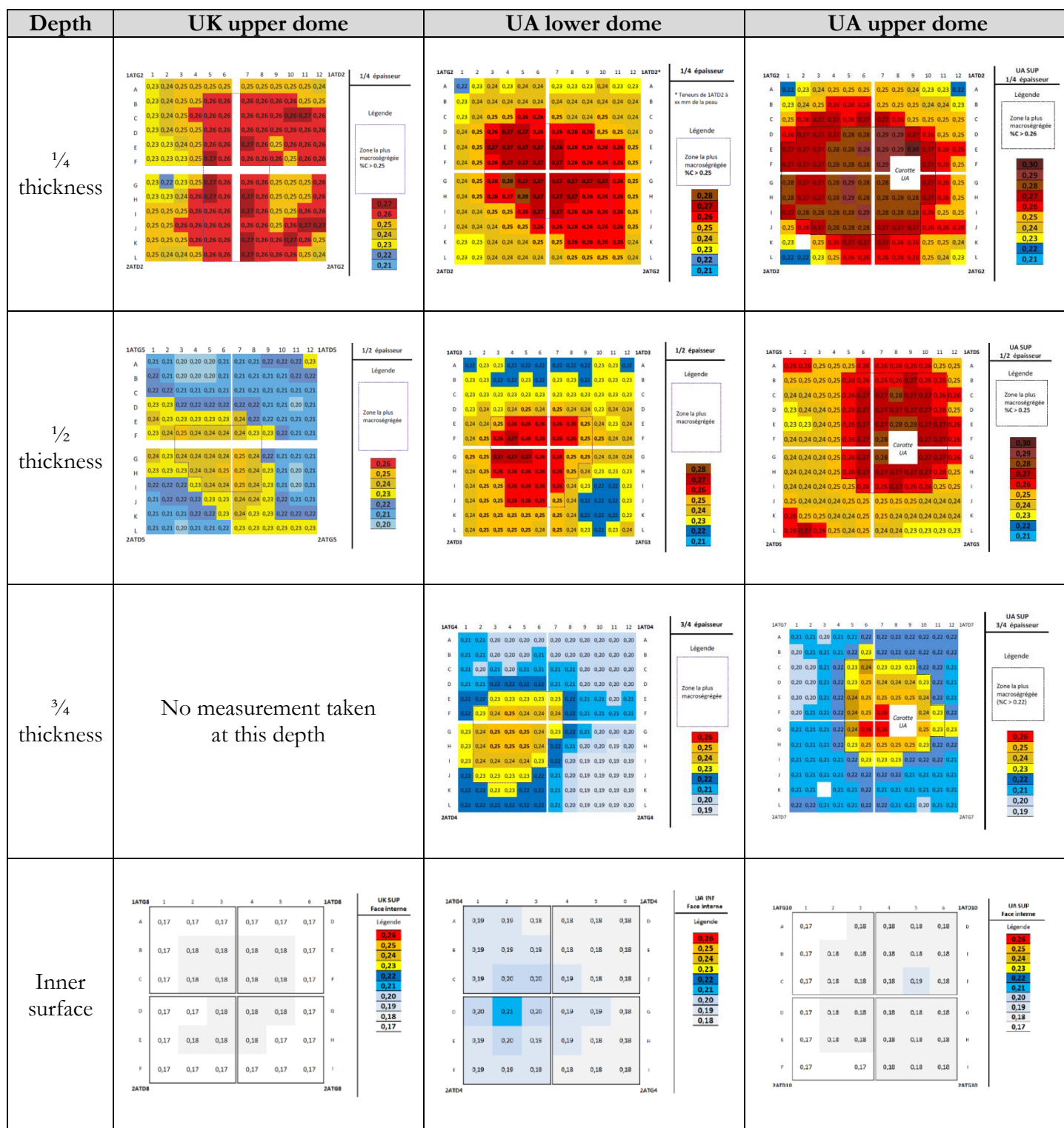

Figure A26 : Synthesis of carbon content mappings by depth (IRC measurements)
Measurement pitch 80 mm x 80 mm

Zone la plus macroségrégée =
Most segregated zone

Appendix 12: List of thermohydraulic situations considered in the mechanical analyses

Hot shock situations

Category 2

- situation 1A1-90: plant unit start-up from cold shutdown to hot shutdown after refuelling;
- situation 20E-3P: unscheduled fluctuations between hot shutdown and cold shutdown.

Category 3

- RIS-RA connection situations in RA mode further to a loss of cooling accident - LOCA (lower dome only);
- situations of natural circulation resumption further to LOCA - two safety injection trains available (lower dome only);
- situations of primary system overpressure when cold (upper dome only).

Category 4

- situation of total loss of cooling by the RIS-RA in C state – variants 1 to 4;
- situations of natural circulation resumption further to LOCA with no safety injection trains available (lower dome);

Cold shock situations

Category 2

- situations 20E-3P and 20A345b: unscheduled fluctuations between hot shutdown and cold shutdown.

Category 3

- situation 3.4: rupture of a steam generator tube;
- situation 3.5.20: small LOCA 20 cm² (2");
- situation 3.7: inadvertent opening of a pressuriser safety valve.

Category 4

- situations 4.3-1 and 4.3-2: loss of primary coolant accident (LOCA) – LOCA 45 cm² and LEP LOCA;
- situations 4.7: loss of feedwater;
- situations 4.8: rapid cooling by secondary cooling system;
- situations 4.10.1 and 4.10.2: LOCA with medium pressure safety injection (ISMP [MHSI]) – LOCA 20 cm² and LOCA 45 cm² respectively;
- accidental rod ejection situation (EDG) (upper dome only);
- accidental situation encompassing cold overpressure situations – Scenario of break in RIS-RA system in RA mode (lower dome only).

Appendix 13: Change in toughness and stress intensity factor as a function of temperature

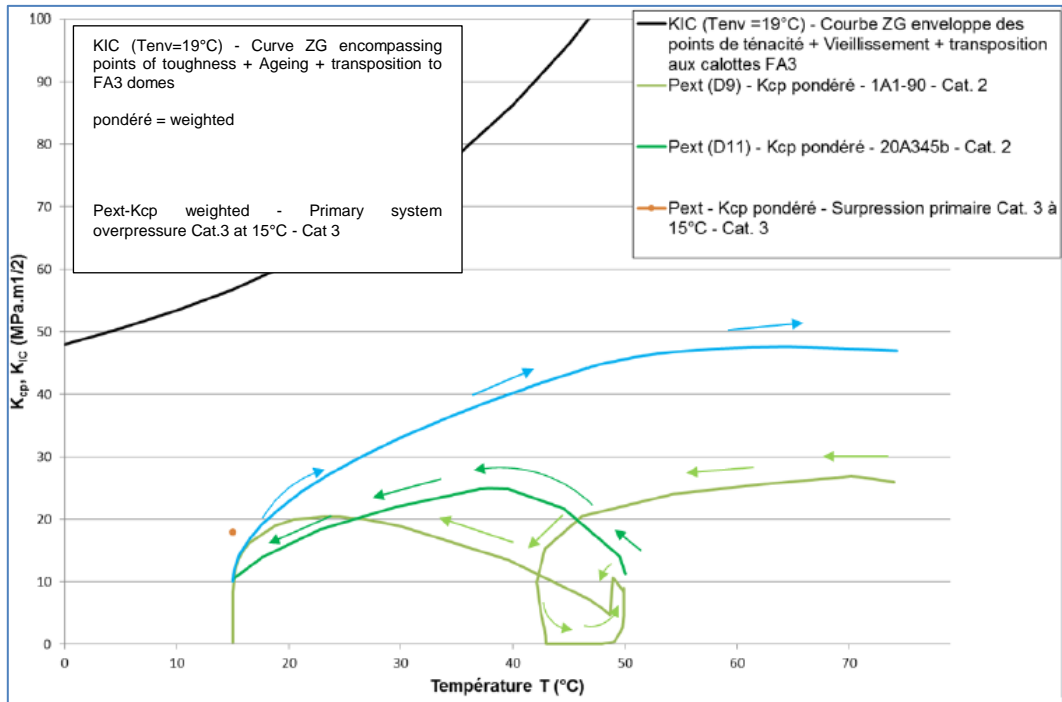

Figure A2. : Figure A27.: Upper dome - 10 mm flaw in outer surface - Indexing temperature of 19°C - Change of stress intensity factor and toughness as a function of temperature for design-basis situations

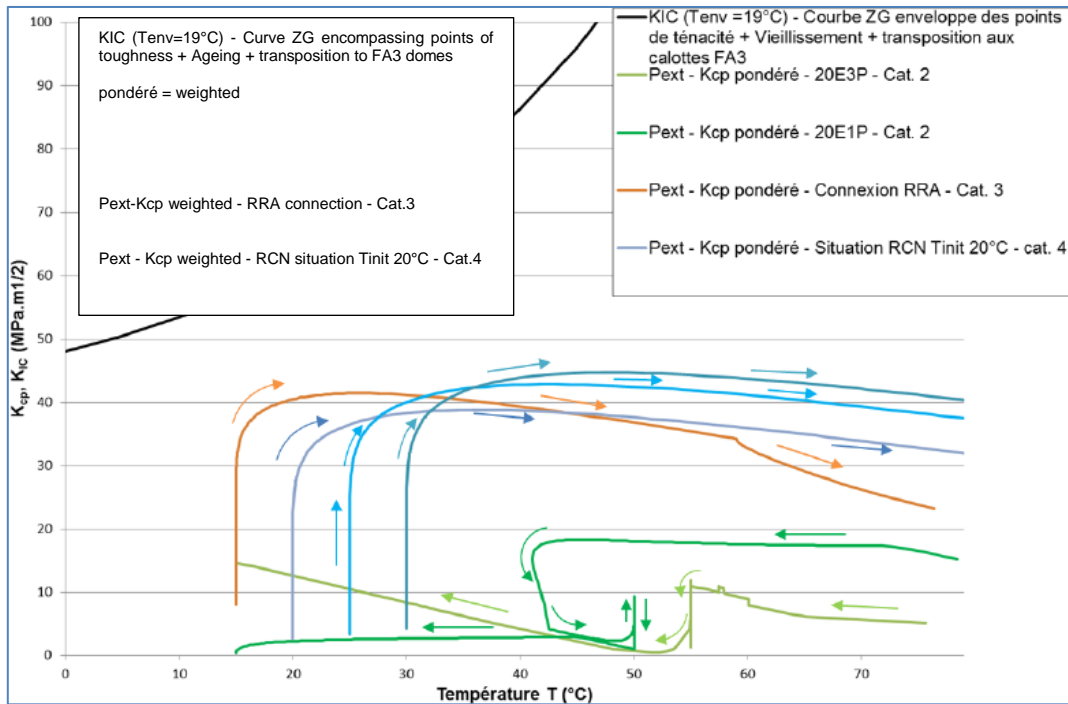

Figure A3. : Figure A27.: Lower dome - 10 mm flaw in outer surface - Indexing temperature of 19°C - Change of stress intensity factor and toughness as a function of temperature for design-basis situations

Appendix 14: Safety factors for the RT_{NDT} offsets of 70°C on outer surface and 35°C on inner surface

| Category | Situation | Designation | Safety factor | Reference |
|----------|--------------|--|---------------|-----------|
| 2 | DDS 20A 345b | Low-amplitude fluctuations between hot shutdown and cold shutdown | 1.79 | [43] |
| 3 | DDS 3.6.1.a | Small steam line break (SLB) without total loss of off-site electrical power supplies (LOOP) | 4.42 | [43] |
| | DDS 3.8.2 | Single-phase overpressure linked to an inadvertent safety injection | 2.55 | [74] |
| 4 | Not in DDS | RIS-RA loss in RA mode in C state | 1.09 | [43] |

Table A3 : Safety factors for the studied hot shock transients of the upper dome, for a surface-breaking flaw in outer surface and a ΔRT_{NDT} (ZS) of 70°C

| Category | Situation | Designation | Safety factor | Reference |
|----------|------------|---|---------------|-----------|
| 2 | DDS 20E-1P | Fluctuations between hot shutdown and cold shutdown | 2.53 | [43] |
| 3 | Not in DDS | Resuming normal circulation (RCN) following a LOCA with small break (20cm ²) in 2 loops | 0.92 | [75] |
| 3 | Not in DDS | Connection of RIS-RA in RA mode | 0.97 | [75] |
| 4 | Not in DDS | RCN in 2 loops | 1.03 | [43] |

Table A4 : Safety factors for the studied hot shock transients of the lower dome, for a surface-breaking flaw in outer surface and a ΔRT_{NDT} (ZS) of 70°C

| Category | Situation | Designation | Safety factor | Reference |
|----------|-------------|--|---------------|-----------|
| 2 | DDS 20A345b | Unscheduled fluctuations between hot shutdown and cold shutdown, low range | 2.41 | [51] |
| 3 | DDS 3.4 a | Fracture of a steam generator tube | 2.51 | [51] |
| 4 | Not in DDS | Rod ejection - Break of 45 cm ² | 2.06 | [51] |

Table A5 : Safety factors for the studied cold shock transients of the upper dome, for a flaw at 1/4 of the thickness of the internal wall and a ΔRT_{NDT} (ZS) of 35°C

| Category | Situation | Designation | Safety factor | Reference |
|----------|------------|--|---------------|-----------|
| 2 | DDS 20E-3P | Single-phase cold overpressure | 2.53 | [51] |
| 3 | DDS 3.4 | Fracture of a steam generator tube | 2.19 | [51] |
| 4 | DDS 4.9.2 | Single-phase cold overpressure further to inadvertent operation of safety injection (IS) | 3.05 | [51] |

Table A6 : Safety factors for the studied cold shock transients of the lower dome, for a flaw at $\frac{1}{4}$ of the thickness of the internal wall and a ΔRT_{NDT} (ZS) of 35°C

| Category | Situation | Designation | Safety factor | Reference |
|----------|------------|--|---------------|-----------|
| 2 | 20A345b | Unscheduled fluctuations between hot shutdown and cold shutdown, low range | 2.00 | [50] |
| 3 | DDS 3.4.a | Fracture of a steam generator tube | 1.77 | [50] |
| 4 | Not in DDS | Rod ejection - Break of 45 cm ² | 1.49 | [50] |

Table A7 : Safety factors for the studied cold shock transients of the upper dome, for a surface-breaking flaw in inner surface and a ΔRT_{NDT} (ZS) of 35°C

| Category | Situation | Designation | Safety factor | Reference |
|----------|--------------|---|---------------|-----------|
| 2 | DDS 20 E- 3P | Fluctuations between hot shutdown and cold shutdown | 2.07 | [50] |
| 3 | DDS 3.8.2 | Single-phase cold overpressure | 1.62 | [50] |
| 4 | Not in DDS | RRA break | 1.57 | [74] |

Table A8 : Safety factors for the studied cold shock transients of the lower dome, for a surface-breaking flaw in inner surface and a ΔRT_{NDT} (ZS) of 35°C

Appendix 15: Areva NP responses to ASN requests

| ASN letter CODEP-DEP-2015-043888 of 14th December 2015 | | | |
|--|--|---|-----------------------------|
| No. | Requests | Opinion of the rapporteur | Section of report concerned |
| 1 | "ASN requests that you perform surface non-destructive tests other than penetrant tests on the RPV lower head, complementary to those already performed as part of the manufacturing process, to confirm the absence of flaws, in a conventional non-destructive testing qualification approach." | Response satisfactory, request satisfied. | § 3.2.2.2 |
| 2 | "ASN requests that you validate, through the test programme, the hypothesis whereby the bending rupture energy mechanical properties of the domes proceeding from mid-thickness towards the interior of the RPV are higher than 60 joules at 0°C. Failing this, ASN requests that you complete the list of situations and the justification file, more specifically by analysing other transients." | The test programme showed that this hypothesis was not validated. The test programme and the list of studied situations were therefore modified. The response is satisfactory. | § 4.3 |
| 3 | "ASN requests that you demonstrate through test results that in the ductile range the material displays sufficiently ductile and tough behaviour, compatible with the design rules used." | Response satisfactory, request satisfied. | § 4.3.6 |
| 4 | "ASN requests that you identify and preserve all the material (test specimens, scraps, etc.) from the domes for further investigations should any be required." | The methods of final preservation are currently being examined. | § 4.1.3.3 |
| 5 | "ASN requests that you indicate the location of the macro-inspections and micro-inspections before starting the test programme and after characterising the extent of the segregation. ASN also requests that you analyse the fracture surfaces of the test specimens." | Response satisfactory, request satisfied. | § 4.1.2.1 § 4.3.8.4 |
| 6 | "ASN requests that you show it the sampling plan you will envisage applying further to these chemical mappings before applying it." | Response satisfactory, request satisfied. | § 4.1.2.1 |
| 7 | "ASN requests that you have the chemical analyses carried out by a laboratory accredited per standard NF EN ISO 17025." | Response satisfactory, request satisfied. | § 4.1.2.2 |
| 8 | "ASN requests that you have part of the mechanical tests, with the exception of the drop-weight tests, carried out by a laboratory that is independent of Areva NP and is accredited per standard NF EN ISO 17025." | Response satisfactory, request satisfied. | § 4.1.2.1 |
| 9 | "ASN requests that you use an approach that allows assessment of: - the conservative nature of the ZG6110 curve of the RCC-M indexed on the end-of-life RT_{NDT} design value minus the offset due to thermal ageing and deformation, and the maximum difference between the acceptance test RT_{NDT} of the Flamanville 3 domes and that of each of the two scale-1 replica domes with respect to the measured toughness values; - the consistency of the local T_{NDT} with the design value." | Response satisfactory, request satisfied. Areva NP provided assessment elements to prove that the local T_{NDT} is higher than the design value. | § 4.3.8 |
| 10 | "ASN requests that you determine : - the indexing temperature that will encompass the toughness measurements in segregated zones; - the indexing temperature resulting from the drop-weight tests in segregated zones; - the indexing temperature resulting from the Charpy impact tests in segregated zones should the local RT_{NDT} not be equal to the local T_{NDT} . "ASN requests that you provide information on the interpretation of the difference between the local T_{NDT} and the local RT_{NDT} locale, if applicable." | Response satisfactory, request satisfied. | § 4.3.8 |
| 11 | "ASN requests that you verify that the indexing temperature encompassing the toughness measurements in segregated zones is lower than the other two indexing temperatures mentioned in request No. 10." | Response satisfactory, request satisfied. | § 4.3.8 |
| 12 | "ASN requests that you verify that the indexing temperatures determined by the test programme remain lower than the maximum allowable indexing temperature that results from the fracture mechanics analyses." | Response satisfactory, request satisfied. | § 6 |
| 13 | "ASN requests that you propose tightened oversight measures for commissioning, operation and in-service monitoring as appropriate for the situation encountered and to carry them over to the equipment instruction manual." | The rapporteur has adopted positions on this point. | § 8 |
| 14 | "ASN requests that you conduct, in relation with the licensee, a technical study of the scenarios for extracting the reactor pressure vessel" | The request has been satisfied. | Appendix 7 |

| | | | |
|--|---|---|------------|
| | body from the reactor building pit and replacing the RPV lower dome. This study must analyse the advantages and drawbacks in terms of the quality of the work done and the safety of the facility." | | |
| 15 | "ASN requests, without prejudice to the results of the future mechanical tests campaign, that you study as from now the manufacture of a new RPV closure head taking into account experience feedback from the design and manufacture of the current head." | Areva NP has provided information on the broad lines that would be adopted in the event of dome replacement. | Appendix 7 |
| ASN letter CODEP-DEP-2016-031435 of 26th September 2016 | | | |
| No. | Requests | Opinion of the rapporteur | |
| 1 | "[ASN] requests that you study, in addition to the hypothetical flaw at three-quarters of the thickness, a hypothetical under-cladding flaw." | Response satisfactory, request satisfied. | § 6.6.3 |
| | "[ASN] considers that depending on the RT_{NDT} values which will be determined in segregated zones, the conservatism of the mechanical analyses for category-4 situations will have to be increased." | Response satisfactory, request satisfied. | § 6.6.1 |
| 2 | "[ASN] requests that you implement inspections using NDT methods to search for under-cladding flaws on the inner surface of the Flamanville EPR RPV lower dome." | Response satisfactory, request satisfied. | § 3.2.2.1 |
| | "In this respect, [ASN] notes your commitment to apply the [proposed] appraisal protocol on toughness and bending rupture energy test specimens selected in accordance with precise criteria." | Response satisfactory, request satisfied. | § 4.3.7 |
| Areva NP letter ARV-DEP-00354 of 11th September 2015 | | | |
| No. | Commitments | Opinion of the rapporteur | |
| 1 | "Areva NP undertakes to: <ul style="list-style-type: none"> - transmit the grinding operation to eliminate the points of contact used for the portable optical emission spectrometry kit; - perform long-duration dye-penetrant inspection of the Flamanville 3 RPV lower head; - perform magnetic particle inspection on a peripheral area of the Flamanville 3 RPV lower head which is free of adapters; - transmit magnetic particle inspection reports for the upper and lower UA domes; - repeat a magnetic particle inspection and a long-duration dye-penetrant examination on the upper UA dome, which has undergone hydrostatic pressure testing since the previous magnetic particle inspection." | Response satisfactory, commitment satisfied. | § 3.2.1 |
| 2 | "For the adequate toughness justification file, Areva NP will take account of the 10-mm flaw and undertakes to supplement the document with sensitivity study assessments for a 20-mm flaw." | Response satisfactory, commitment satisfied. | § 6.5 |
| 3 | For the on-site test cases, AREVA agrees initially to consider the 20-mm flaw to define the hydrostatic pressure test temperature and, if the analysis with the conventional flaw leads to hydrostatic pressure test temperature that is industrially constraining or prohibitive, consistently with the RCC-M, to: <ul style="list-style-type: none"> - consider the start-of-life mechanical properties for the initial hydrostatic test (no ageing) and end-of-life properties for the requalification tests; - set an industrially reasonable hydrostatic pressure test temperature; - determine the flaw that that is strictly compliant with the criteria of the RCC-M code; - compare it with the detection limit flaw." | The commitment was satisfied for the in-factory hydrostatic test. The commitment is still valid for the on-site hydrostatic tests. | - |
| 4 | "Areva NP and EDF undertake to provide a more complete file demonstrating that an ageing programme is not pertinent [...]." | Response satisfactory, request satisfied. | § 4.1.2.4 |
| 5 | "Areva NP undertakes to perform chemical characterisation of the UA lower dome applying the same programme as will be used on the UK scale-1 replica upper dome. Complementary to this chemical characterisation, Areva NP undertakes to perform a complete programme of mechanical tests, identical to the one that will be performed on the UK scale-1 replica upper dome." | Response satisfactory, commitment satisfied. | § 4.1.2.1 |
| 6 | "To enable all the characteristics, and RT_{NDT} in particular, to be obtained with the same reference value, as far as the stress-relief heat treatments are concerned, Areva NP undertakes to perform all the qualification programme tests on specimens that will have undergone the stress-relief treatment required by the procurement specifications." | Response satisfactory, commitment satisfied. | § 4.1.2.1 |
| 7 | "Areva NP will perform the toughness tests in the ductile range and verify the adequacy of the toughness obtained. | Response satisfactory, commitment satisfied. | § 4.3 |

| | | | |
|---|---|--|---------------------|
| | Areva NP points out that the design and manufacturing rules usually applied for pressure equipment necessitate a material that displays sufficient ductility: Areva NP undertakes to ensure a minimum value for elongation at break of 14% as required by the DESP (pressure equipment) decree for the macro-segregated area of the FA3 domes." | | |
| 8 | <p>"As indicated in the test programme PFCSGN/NCR0002, Areva NP undertakes to treat the measurement uncertainties in accordance with the requirements of each test standard used. The measurement uncertainties are quantified for the tensile, toughness and bending rupture energy tests.</p> <p>Areva NP undertakes to present the procedures used for the drop-weight tests which prove proficiency in performing the test.</p> <p>For the chemical measurements, it is generally accepted that combustion of chips is the method that allows the composition of a sample to be quantified to within a few thousandths of a percent.</p> <ul style="list-style-type: none"> - Areva NP undertakes to draw up a specific protocol for evaluating this uncertainty. - Areva NP undertakes to ensure that the preparation of the test specimens and the performance of the chemical analyses and the drop-weight tests are carried out under the surveillance of Bureau Veritas Exploitation which will act on a mandate issued by ASN-DEP. Bureau Veritas will monitor compliance with the specimen sampling and preparation methods, particularly for the drop-weight test specimens, and the test methods, which will be described in Areva NP's particular procedures. Attention shall also be paid to compliance with the quantified parameters of these procedures and more particularly for the drop-weight tests." | Response satisfactory, commitment satisfied. | § 4.1.3 and 4.1.2.3 |
| 9 | "Areva NP undertakes to analyse the impact of the change of standards on the test results, between the standards applicable to the FA3 project and those that will be used for the test programme." | Response satisfactory, commitment satisfied. | § 4.1.3 |

Tableau A1. : Table A9 : Requests in the ASN position letters [7] and [10] and Areva NP commitments [26]